

# MCZ GROUP

**RAY COMFORT AIR 8 UP! M1 UNTIL S/N 1906260060004**

Gruppo estetico / Aesthetic group / Ästhetische Gruppe / Groupe esthétique / Grupo estético

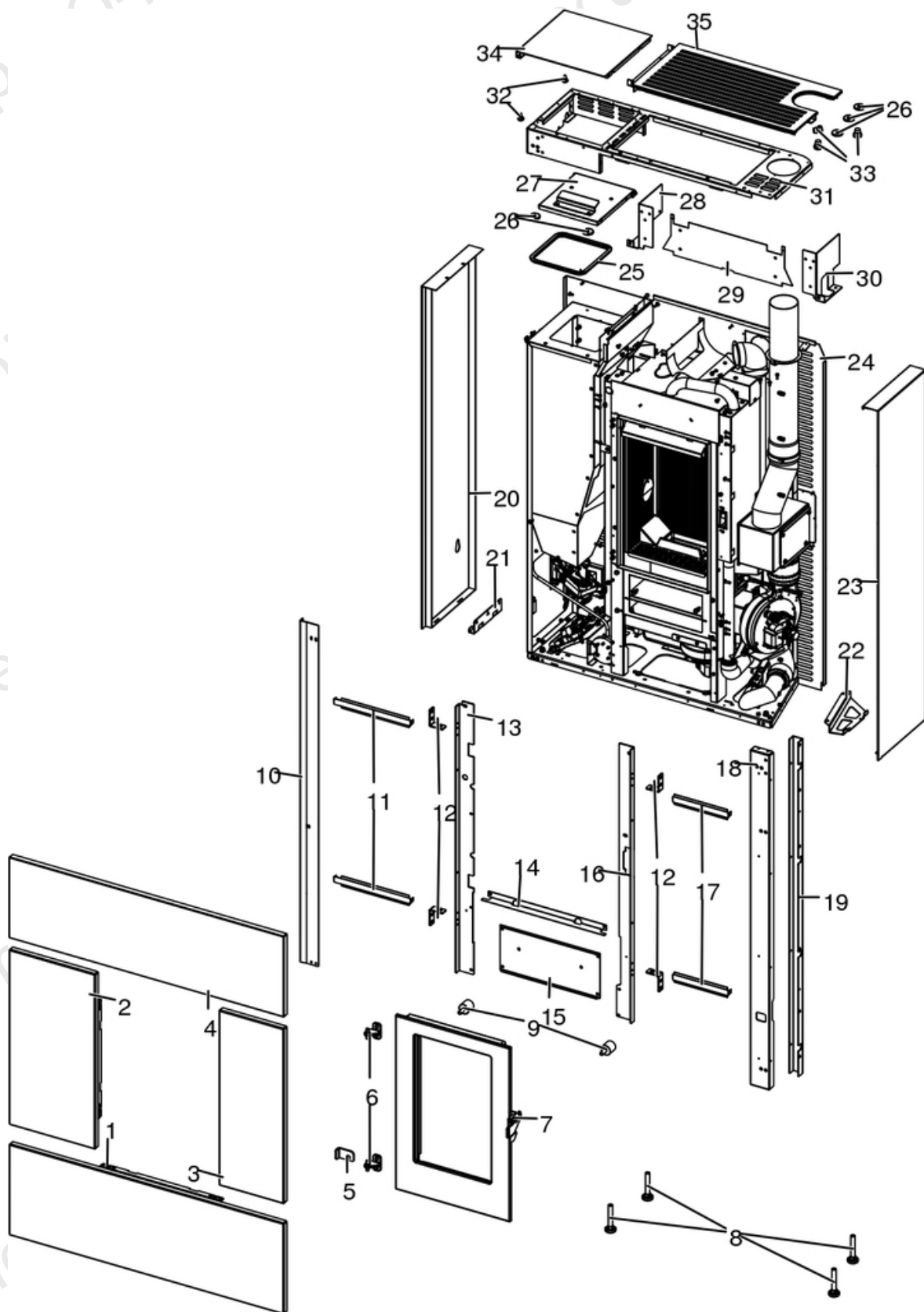

N°	Codice/Code	Descrizioni / Description / Beschreibung / Description / Descripcion
1	4125180075000	Ceramica inferiore White / White lower ceramic / Untere Keramik White / Carreau inférieur en céramique White / Cerámica inferior White
1	4125180075001	Ceramica inferiore Bordeaux / Burgundy lower ceramic / Untere Keramik Bordeaux / Carreau inférieur en céramique Bordeaux / Cerámica inferior Burdeos
1	4125180075002	Ceramica inferiore Black / Lower ceramic Black / Untere Keramik Black / Carreau inférieur en céramique Black / Cerámica inferior Black
1	6918012	Rivestimento completo Serpentino / Complete Serpentino cladding / Komplette Verkleidung Serpentino / Habillage complète en Serpentino / Revestimento completo en Serpentino
1	41251801050	Frontale inferiore in Serpentino / Frontal lower Serpentino stone / Vordere untere Serpentino Stein / Frontal inférieur en Serpentino / Frontale inferior en Serpentino
2	4125180085000	Ceramica laterale SX White / L. White side ceramic / LI. Seitliche Keramik White / Céramique latérale G. White / Cerámica lateral IZDA White
2	4125180085001	Ceramica laterale SX Bordeaux / L. Burgundy side ceramic / LI. Seitliche Keramik Bordeaux / Céramique latérale G. Bordeaux / Cerámica lateral IZDA Burdeos
2	4125180085002	Ceramica laterale SX Black / L. Black side ceramic / LI. Seitliche Keramik Black / Céramique latérale G. Black / Cerámica lateral IZDA Black
2	6918012	Rivestimento completo Serpentino / Complete Serpentino cladding / Komplette Verkleidung Serpentino / Habillage complète en Serpentino / Revestimento completo en Serpentino
3	4125180095000	Ceramica laterale DX White / R. White side ceramic / RE. Seitliche Keramik White / Céramique latérale D. White / Cerámica lateral DCHA White
3	4125180095001	Ceramica laterale DX Bordeaux / R. Burgundy side ceramic / RE. Seitliche Keramik Bordeaux / Céramique latérale D. Bordeaux / Cerámica lateral DCHA Burdeos
3	4125180095002	Ceramica laterale DX Black / R. Black side ceramic / RE. Seitliche Keramik Black / Céramique latérale D. Black / Cerámica lateral DCHA Black
3	6918012	Rivestimento completo Serpentino / Complete Serpentino cladding / Komplette Verkleidung Serpentino / Habillage complète en Serpentino / Revestimento completo en Serpentino
3	41251801350	Laterale DX in Serpentino / R. Lateral Serpentine stone / RE. Seite aus Serpentino / Latérale D. en Serpentine / Lateral DCHO en Serpentino
4	4125180065000	Ceramica superiore White / White upper ceramic / Obere Keramik White / Céramique supérieure White / Cerámica superior White
4	4125180065001	Ceramica superiore Bordeaux / Burgundy upper ceramic / Obere Keramik Bordeaux / Céramique supérieure Bordeaux / Cerámica superior Burdeos
4	4125180065002	Ceramica superiore Black / Black upper ceramic / Obere Keramik Black / Céramique supérieure Black / Cerámica superior Black
4	6918012	Rivestimento completo Serpentino / Complete Serpentino cladding / Komplette Verkleidung Serpentino / Habillage complète en Serpentino / Revestimento completo en Serpentino
5	4141184413000	Blocco porta ghisa / Door stop cast iron / Türstopper Guß / Stop pour porte fonte / Tope por puerta arrabio
6	41201504460	Cerniera porta (2 pz.) / Door hinge (2 pc.) / Tür Scharnier (2 Stk.) / Charnière porte (2 pc.) / Bisagra puerta (2)
7	437018069	Porta focolare / Fireplace door / Feuerstelle Tür / Porte foyer / Puerta hogar
8	41200906660	Piedini di appoggio (4 pz.) / Support feet (4 pcs.) / Einstellfüße (4 Stck.) / Vérins d'appui (4 p.es) / Pies de apoyo (4 piezas)
9	41201105600	Antivibranti (10 pz) / anti-vibration mountings (10 pcs) / Schwingungsdämpfer (10 Stck) / Éléments antivibratoires (10 pcs) / Anti-vibraciones (10 pz)
10	41401807430	Montante sx / L. upright / Aufrecht L. / Droit G. / Vertical IZDO
11	4141184903100	Tamponazione sx frontale / Frontal filler L. / Vordere Stopfung L. / Plaque frontal G. / Tapa frontal IZDA
12	4141184933000	Squadretta / Bracket / Klammer / Support / Soporte
13	4141184864000	Tamponazione interna / Internal filler / Innere Abdichtung / Tampon interieur / Taponado
14	4141184923000	Tamponazione inferiore frontale / Lower frontal filler / Untere Vordere Stopfung / Plaque frontal inférieure / Tapa frontal inferior
15	437018076	Tappo cenere / Ash cap / Asche Verschluss / Bouchon cendre / Tapón ceniza
16	4141184874000	Tamponazione interna dx / Internal filler R. / Innere Abdichtung R. / Tampon interieur D. / Taponado DCHO
17	4141184913100	Tamponazione dx frontale / Frontal filler R. / Vordere Stopfung R. / Plaque frontal D. / Tapa frontal DCHA
18	41401727231	Montante anteriore / Frontal upright / Vorderaufrecht / Droit frontal / Vertical delantero
19	41401807530	Montante dx / R. upright / Aufrecht R. / Droit D. / Vertical DCHO
20	4141184854000	Fianco sx / L. side / Seite L. / Côté G. / Lateral IZDO
21	41401806530	Supporto fianco dx / Support R. side / Stütze Seiten R. / Support côté D. / Soporte lado DCHO
22	41401721030	Supporto fianco dx / Support R. side / Stütze Seiten R. / Support côté D. / Soporte lado DCHO

<b>23</b>	<b>4141184844100</b>	Fianco dx / R. side / Seite R. / Côté D. / Lateral DCHO
<b>24</b>	<b>41401806831</b>	Schiena posteriore / Back / Hintere Rückwand / Dossieret postérieur / Parte trasera
<b>25</b>	<b>41801604700</b>	Guarnizione tenuta serbatoio / Pellet hopper gasket / Pelletbehälter Dichtung / Joint réservoir pellet / Junta depósito pellet
<b>26</b>	<b>41801657900</b>	Magneti (pz.2) / Magnet (pcs.2) / Magnet (stk. 2) / Aimant (pcs.2) / Imán (pz.2)
<b>27</b>	<b>41401714650</b>	Coperchio tecnico / Technical cover / Technicher Deckel / Couvercle technique / Tapadera técnica
<b>28</b>	<b>4141185553000</b>	Tamponazione sx / Filler L. / Stopfung L. / Tampon G. / Taponado IZDO
<b>29</b>	<b>41401813210</b>	Tamponazione anteriore / Frontal filling / Vorderabdichtung / Tampon frontal / Taponado frontal
<b>30</b>	<b>4141184463000</b>	Tamponazione / Filler / Stopfung / Tampon / Taponado
<b>31</b>	<b>4141184473000</b>	Supporto top / Top support / Deckelhalbteügel / Support du dessus / Soporte del top
<b>32</b>	<b>41801002300</b>	Paracolpi in silicone Ø 8/5 (2pz) / Silicone bumpers Ø 8/5 (2pcs) / Schlagschutzgummi Ø 8/5 (2 Stck) / Pièces silicone antichoc Ø 8/5 (2pcs) / Anti-golpes en silicona Ø 8/5 (2pzs)
<b>33</b>	<b>4120180</b>	Gommini paracolpi (4 pz) / Rubber bumpers (4 pcs.) / Schlagschutzgummi (4 Stck) / Pièces caoutchouc antichoc (4 pcs) / Cauchitos anti-golpes (4 pz)
<b>34</b>	<b>4141184814000</b>	Coperchio pellet / Pellet hopper cover / Deckel Pelletbehälter / Couvercle réservoir pellet / Tapadera depósito pellet
<b>35</b>	<b>4141184824000</b>	Top / Top / Abdeckplatte / Dessous / Top

## RAY COMFORT AIR 8 UP! M1 UNTIL S/N 1906260060004

Gruppo camera di combustione - ghisa / Combustion chamber group - cast iron / Verbrennungskammer Gruppe - Gusseisen / Groupe chambre de combustion - fonte / Grupo cámara de combustión - arrabio

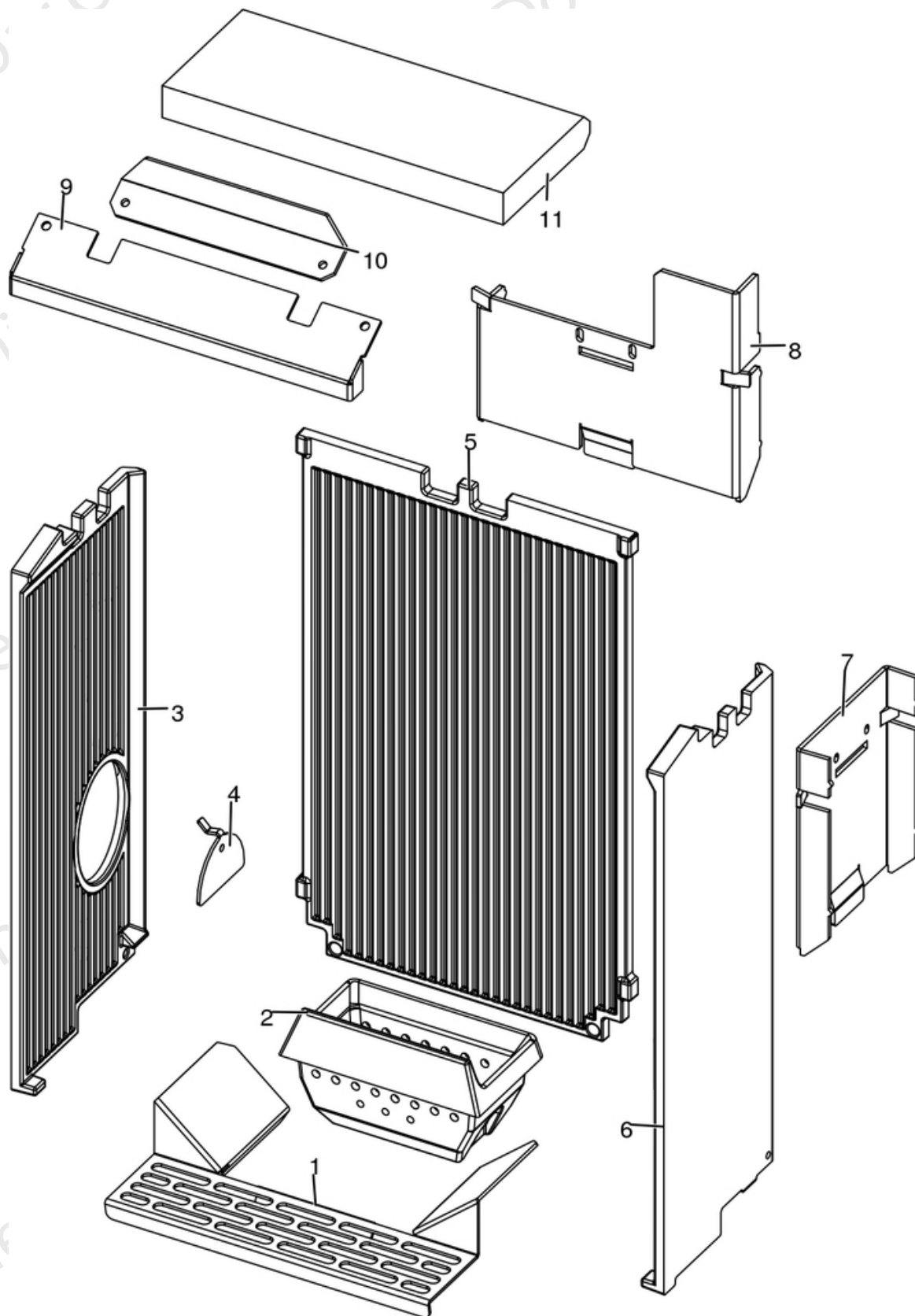

N°	Codice/Code	Descrizioni / Description / Beschreibung / Description / Descripción
1	41411742230V	Griglia focolare / Fire box grille / Feuerstellenrost / Grille foyer / Rejilla hogar
2	4130170030100	Braciere ghisa / Cast iron brazier / Brennschale aus Guß / Brasero en fonte / Brasero de arrabio
3	41802299950	Kit focolare in vermiculite / Combustion chamber kit in vermiculite / Feuerraum-Kit aus Vermiculite / Kit foyer en vermiculite / Kit cámara de combustión en vermiculita
3	41301700600V	Fianco sinistro in ghisa nera / Black L. side / Aussenseite L. schwarz / Côté G. noir / Lateral IZDO negro
4	41411613530V	Deflettore pellet / Pellet deflector / Pellet Leitblech / Deflecteur pellet / Deflector pellet
5	41802299950	Kit focolare in vermiculite / Combustion chamber kit in vermiculite / Feuerraum-Kit aus Vermiculite / Kit foyer en vermiculite / Kit cámara de combustión en vermiculita
5	41301700700V	Schiena in ghisa nero / Black cast iron back / Rückwand aus Guß schwarz / Fond en fonte noir / Parte trasera de arrabio negro
6	41802299950	Kit focolare in vermiculite / Combustion chamber kit in vermiculite / Feuerraum-Kit aus Vermiculite / Kit foyer en vermiculite / Kit cámara de combustión en vermiculita
6	41301700500V	Fianco destro in ghisa nero / Black right cast iron side / Rechte Seite aus Guß schwarz / Coté droit en fonte noir / Placa lateral derecha de arrabio negro
7	41411740231	Tappo lat. pulizia struttura / Lateral cap for structure cleaning / Seitlicher Stöpsel für Korpus Reinigung / Bouchon lateral pour nettoyage structure / Tapon lateral por limpieza estructura
8	41411740131	Tappo post. pulizia struttura / Rear cap for structure cleaning / Hinterer Stöpsel für Korpus Reinigung / Bouchon postérieur pour nettoyage structure / Tapon posterior por limpieza estructura
9	4141174234200	Deflettore pulizia vetro / Deflector for glass cleaning / Leitblech für Glassreinigung / Deflecteur pour nettoyage / Deflector por limpieza vidrio
10	41331702031	Protezione focolare inox / Inox fire protection / Feuerschutz aus Edelstahl / Protection foyer inox / Protección hogar inox
11	41151702000	Deflettore vermiculite / Vermiculite deflector / Leitblech aus Vermiculite / Défecteur en vermiculite / Deflector en vermiculite

## RAY COMFORT AIR 8 UP! M1 UNTIL S/N 1906260060004

Gruppo camera di combustione - vermiculite / Combustion chamber group – vermiculite /  
Verbrennungskammer Gruppe - Vermiculite / Group de chambre de combustion - vermiculite / Grupo  
cámara de combustión – vermiculite

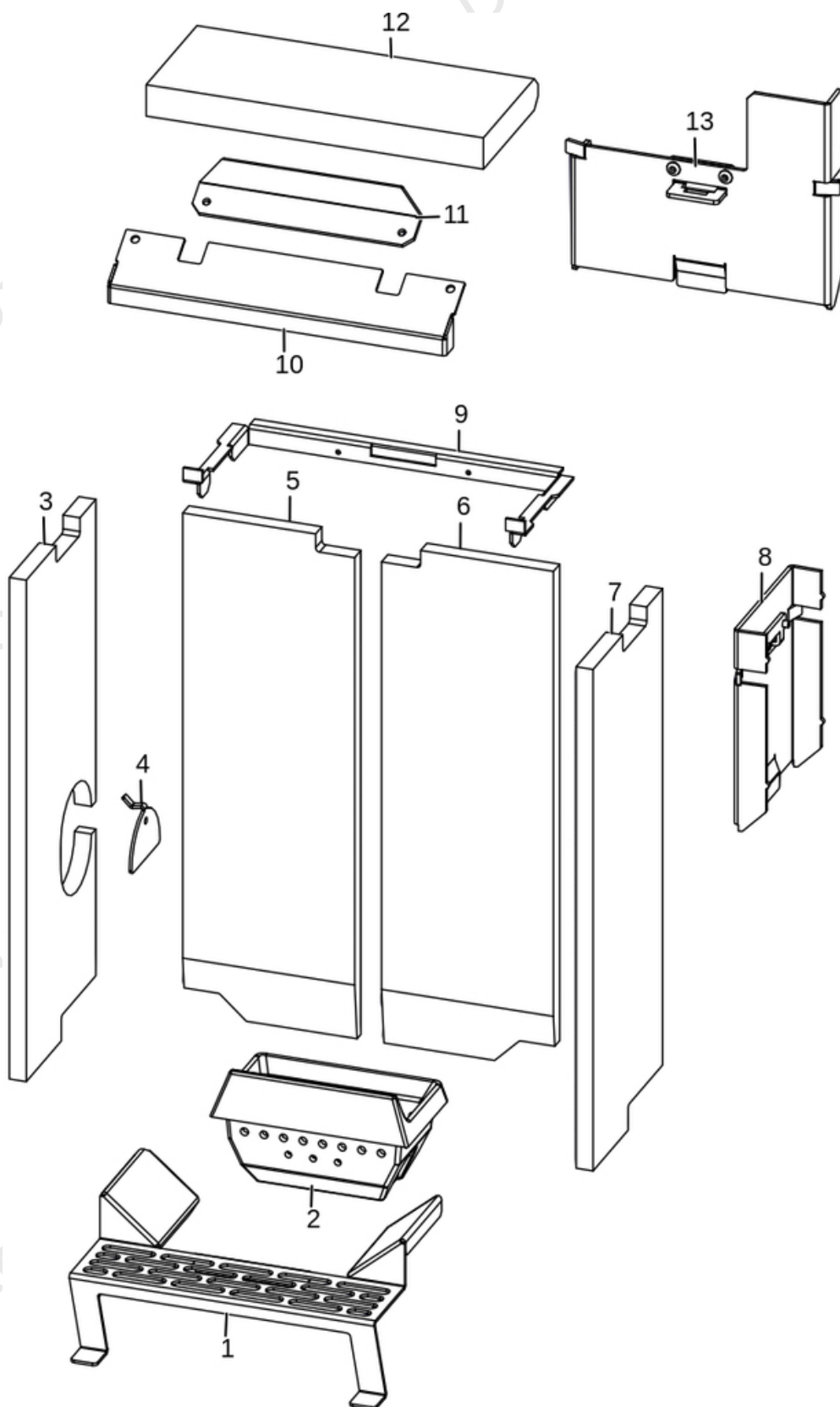



N°	Codice/Code	Descrizioni / Description / Beschreibung / Description / Descripcion
1	4140222563000	* / * / * / * / *
2	4130170030100	Braciere ghisa / Cast iron brazier / Brennschale aus Guß / Brasero en fonte / Brasero de arrabio
3	41152006500	* / * / * / * / *
4	41411613530V	Deflettore pellet / Pellet deflector / Pellet Leitblech / Deflecteur pellet / Deflector pellet
5	41152006700	* / * / * / * / *
6	41152006800	* / * / * / * / *
7	41152006600	* / * / * / * / *
8	41411740231	Tappo lat. pulizia struttura / Lateral cap for structure cleaning / Seitlicher Stöpsel für Korpus Reinigung / Bouchon lateral pour nettoyage structure / Tapon lateral por limpieza estructura
9	41402225530	* / * / * / * / *
10	4141174234200	Deflettore pulizia vetro / Deflector for glass cleaning / Leitblech für Glassreinigung / Deflecteur pour nettoyage / Deflector por limpieza vidrio
11	41331702031	Protezione focolare inox / Inox fire protection / Feuerschutz aus Edelstahl / Protection foyer inox / Protección hogar inox
12	41151702000	Deflettore vermiculite / Vermiculite deflector / Leitblech aus Vermiculite / Défecteur en vermiculite / Deflector en vermiculite
13	41411740131	Tappo post. pulizia struttura / Rear cap for structure cleaning / Hinterer Stöpsel für Korpus Reinigung / Bouchon posterieur pour nettoyage structure / Tapon posterior por limpieza estructura

## RAY COMFORT AIR 8 UP! M1 UNTIL S/N 1906260060004

Porta fuoco / Fire door / Feuertür / Porte foyer / Puerta hogar

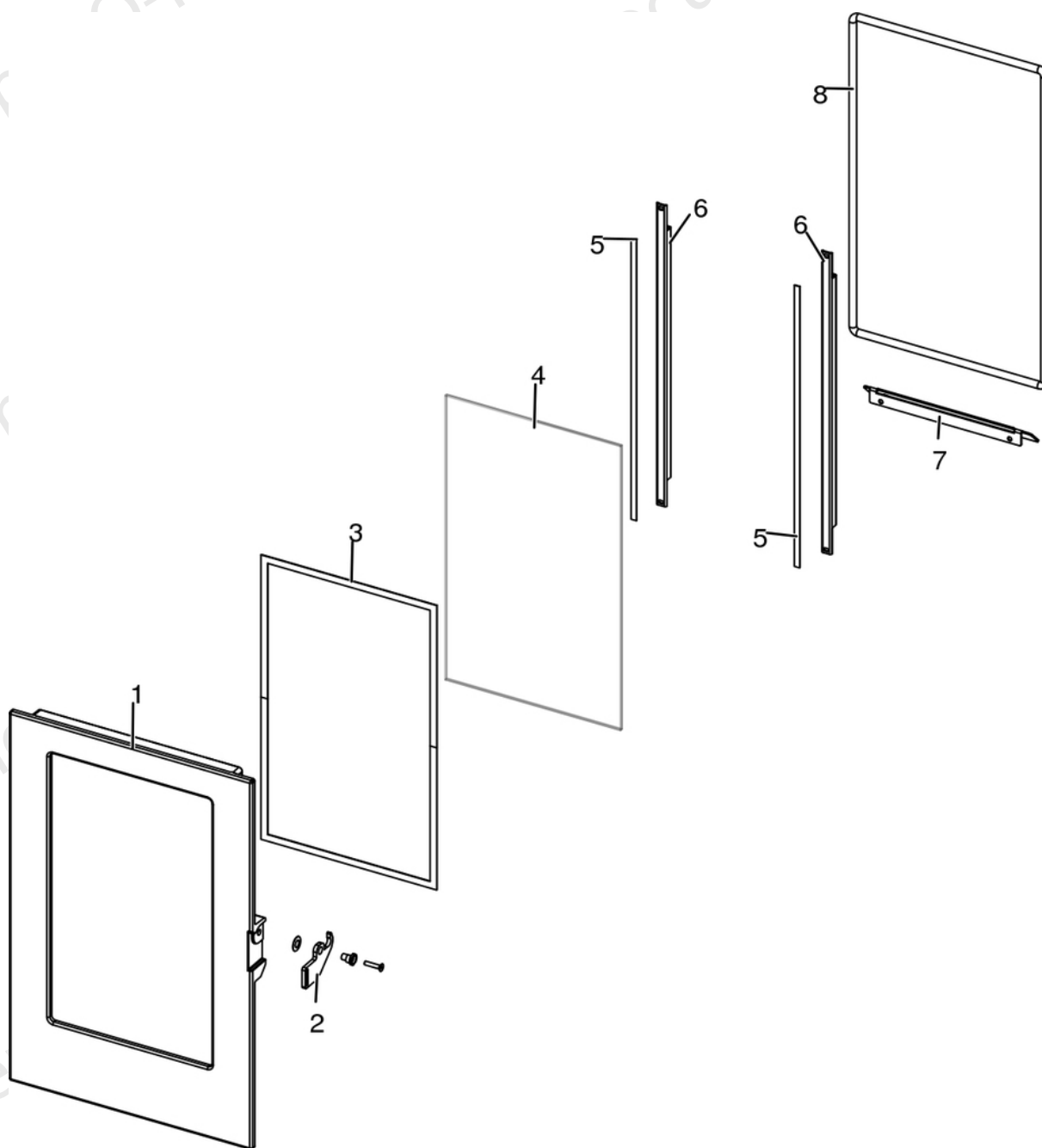

N°	Codice/Code	Descrizioni / Description / Beschreibung / Description / Descripción
1	4130170370000	Porta in ghisa / Cast iron door / Tür aus Gusseisen / Porte en fonte / Puerta de arrabio
2	41411844261	Maniglia porta / Door Handle / Türgriff / Poignée porte / Tirador
3	41801603300A	Guarnizione Ø5 5mt / Gasket Ø5 5mt / Dichtung Ø5 5mt / Joint Ø5 5mt / Junta Ø5 5mt
3	41801603300B	Guarnizione Ø5 50mt / Gasket Ø5 50mt / Dichtung Ø5 50mt / Joint Ø5 50mt / Junta Ø5 50mt
3	41801603300C	Guarnizione Ø5 5mt + silicone / Gasket Ø5 5mt + silic / Dichtung Ø5 5mt + Silikon / Joint Ø5 5mt + silic / Junta Ø5 5mt
4	41701701800	Vetroceramico porta tecnica / Technical door glass / Glas für technische Tür / Vitrocéramique porte technique / Cristal cerámico puerta técnica
5	4120573A	Guarnizione a nastro 8 mm (5 mt.) per porta / Door strip gasket 8 mm (5 m) / Türbanddichtung 8 mm (5 m) / Joint ruban 8 mm (5 m) pour porte / Guarnición de cinta para puerta 8 mm (5 m)



<b>5</b>	<b>4120573B</b>	Guarnizione a nastro 8 mm (50 mt.) per porta / Door strip gasket 8 mm (50 m) / Türbanddichtung 8 mm (50 m) / Joint ruban 8 mm (50 m) pour porte / Guarnición de cinta para puerta 8 mm (50 m)
<b>6</b>	<b>4160170440000</b>	Profilo fermavetro / Fastening bracket profile / Haltebügel für Scheibebefestigung Profil / Profil patte de fixation / Perfil fermacristal
<b>7</b>	<b>4141174203200</b>	Scivolo cenere / Ash ramp / Aschenrutsche / Glissière cendre / Tobogán ceniza
<b>8</b>	<b>4120104A</b>	Cordino fibroceramico Ø 12 mm (5 mt.) / Ceramic fibre cord Ø 12 mm (5 m.) / Keramikfaserschnur Ø 12 mm (5 m) / Cordon en fibre céramique Ø 12 mm (5 m) / Junta a cuerda de fibra cerámica Ø 12 mm (5 m)
<b>8</b>	<b>4120104B</b>	Cordino fibroceramico Ø 12 mm (50 mt.) / Ceramic fibre cord Ø 12 mm (50 m.) / Keramikfaserschnur Ø 12 mm (50 m) / Cordon en fibre céramique Ø 12 mm (50 m) / Junta a cuerda de fibra cerámica Ø 10 mm (52 m)
<b>8</b>	<b>41201041</b>	Kit sostituzione cordino (cordino+silicone) Ø 12 mm / Cord replacement kit (cord + silicon) Ø 12 mm / Schnuraustauschsatz (Schnur+Silikon) Ø 12 mm / Kit remplacement cordon (cordon + silicone) Ø 12 mm / Kit sustitución junta a cuerda (junta a cuerda+silicón) Ø 12 mm

## RAY COMFORT AIR 8 UP! M1 UNTIL S/N 1906260060004

Gruppo caricamento pellet / Pellet feed group / Pellet Fördergruppe / Groupe chargement du pellet / Grupo de carga pellet

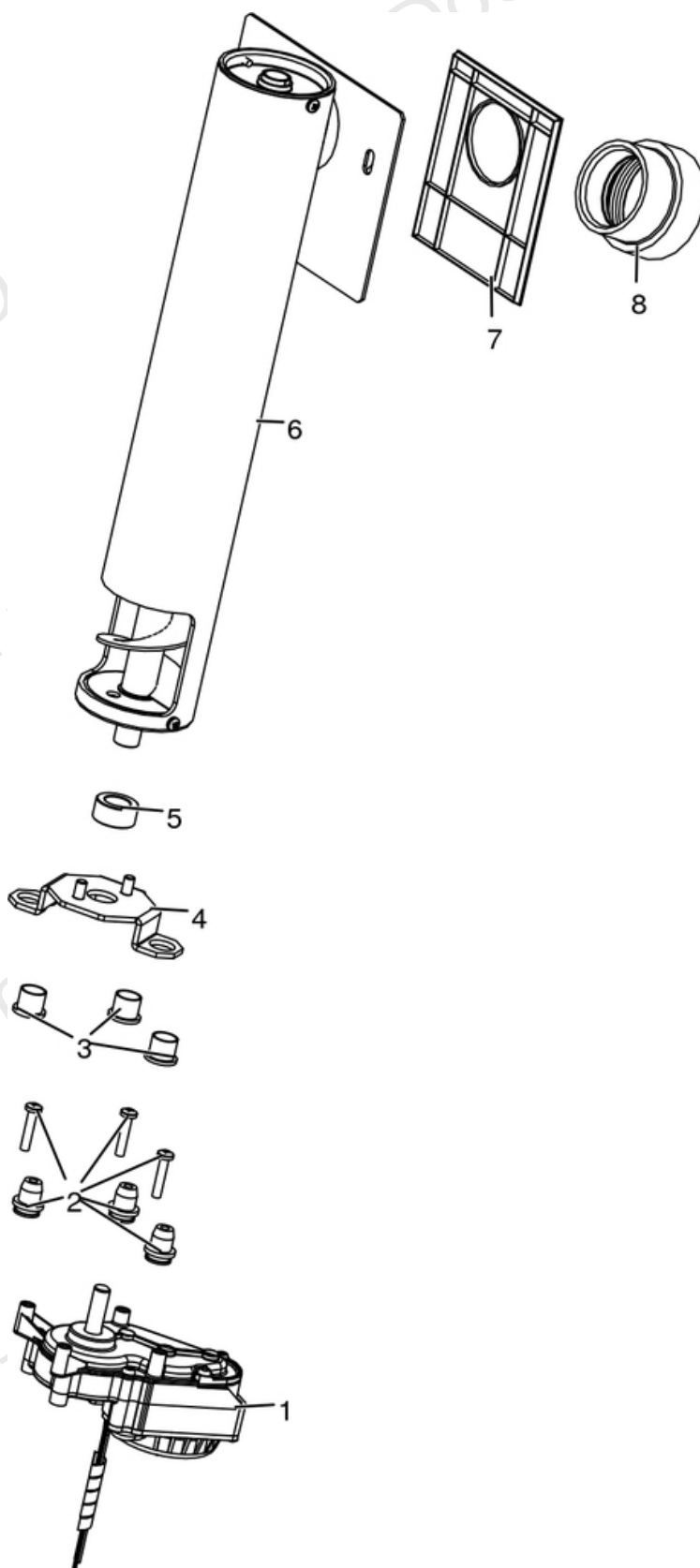

N°	Codice/Code	Descrizioni / Description / Beschreibung / Description / Descripción
1	41451702200	Motoriduttore brushless / Brushless reduction motor / Brushless Getriebemotor / Motoréducteur brushless / Motorreductor brushless
2	41801703700	Gommini antivibrante / Vibration damper rubber / Rammschutz Gummi / Caoutchouc antivibratoire / Cauchitos antivibración
3	41201800700	Boccola (3 pz) / Bushing (3 pcs) / Buchse (3 Stk) / Douille (3 pcs) / Abrazadera (3 pzs)
4	41411779331	Supporto coclea "Ragno" / Pellet feed screw bracket "spider" / "Spinne" Schenke Gestell / Support vis sans fin "Araignée" / Soporte coclea "Araña"
5	4120398	Connettore motoriduttore-coclea / Reduction motor-feed screw connector / Verbindung Getriebemotor-Schnecke / Connecteur motoréducteur-vis sans fin / Conector motorreductor-cóclea
6	41411741151	Alimentazione completa / Complete power / Komplette Anspeisung / Alimentation complète / Alimentacion completa
7	41801600400	Guarnizione gruppo caricamento / Gasket / Dichtung / Joint / Junta
8	41801702600	Guarnizione / Gasket / Dichtung / Joint / Junta

## RAY COMFORT AIR 8 UP! M1 UNTIL S/N 1906260060004

Gruppo accensione / Ignition group / Entzündung Gruppe / Groupe d'allumage / Grupo ignición

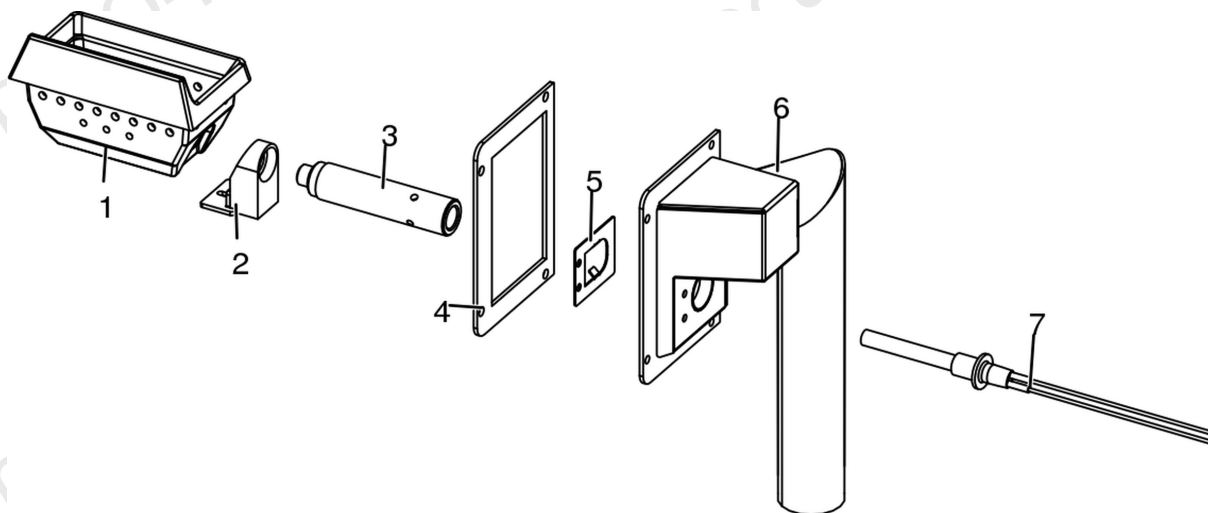

N°	Codice/Code	Descrizioni / Description / Beschreibung / Description / Descripción
1	4130170030100	Braciere ghisa / Cast iron brazier / Brennschale aus Guß / Brasero en fonte / Brasero de arrabio
2	41411741740V	Blocchetto / Little stop / Kleiner Stopper / Petit stop / Tope pequeno
3	41201705400	Condotto candelella / Sparkplug conduit / Zündkerzenkanal / Conduit bougie / Conducto bujía
4	41801702000	Guarnizione scatola / Box gasket / Gehäuse Dichtung / Joint de boite / Burlete caja
5	41401711131	Staffa a molla / Spring bracket / Federhalterung / Support à ressort / Soporte de resorte
6	41411741440V	Scatola aspirazione / Air inlet box / Lufteingangs Schachtel / Coffret entrée d'air / Caja entrada aire
7	41451308101	Candelella 315 Watt / Sparkplug 315 Watt / Zündkerze 315 Watt / Bougie 315 Watt / Bujía 315 Watt
7	41451308150	Kit 25 candelette 315 Watt / 25 Sparkplugs 315 Watt kit / Bausatz 25 Zündkerzen 315 Watt / Kit 25 Bougies 315 Watt / Kit 25 Bujías 315 Watt
7	41452009900	Candelella 300 Watt / Sparkplug 300 Watt / Zündkerze 300 Watt / Bougie 300 Watt / Bujía 300 Watt

## RAY COMFORT AIR 8 UP! M1 UNTIL S/N 1906260060004

Gruppo elettrico ed elettronico fino al SN 2102240060030 / Electrical and electronic group up to SN 2102240060030 / Elektrische und elektronische Gruppe bis zur SN 2102240060030 / Groupe électrique et électronique jusqu'au NS 2102240060030 / Grupo eléctrico y electrónico hasta NS 2102240060030

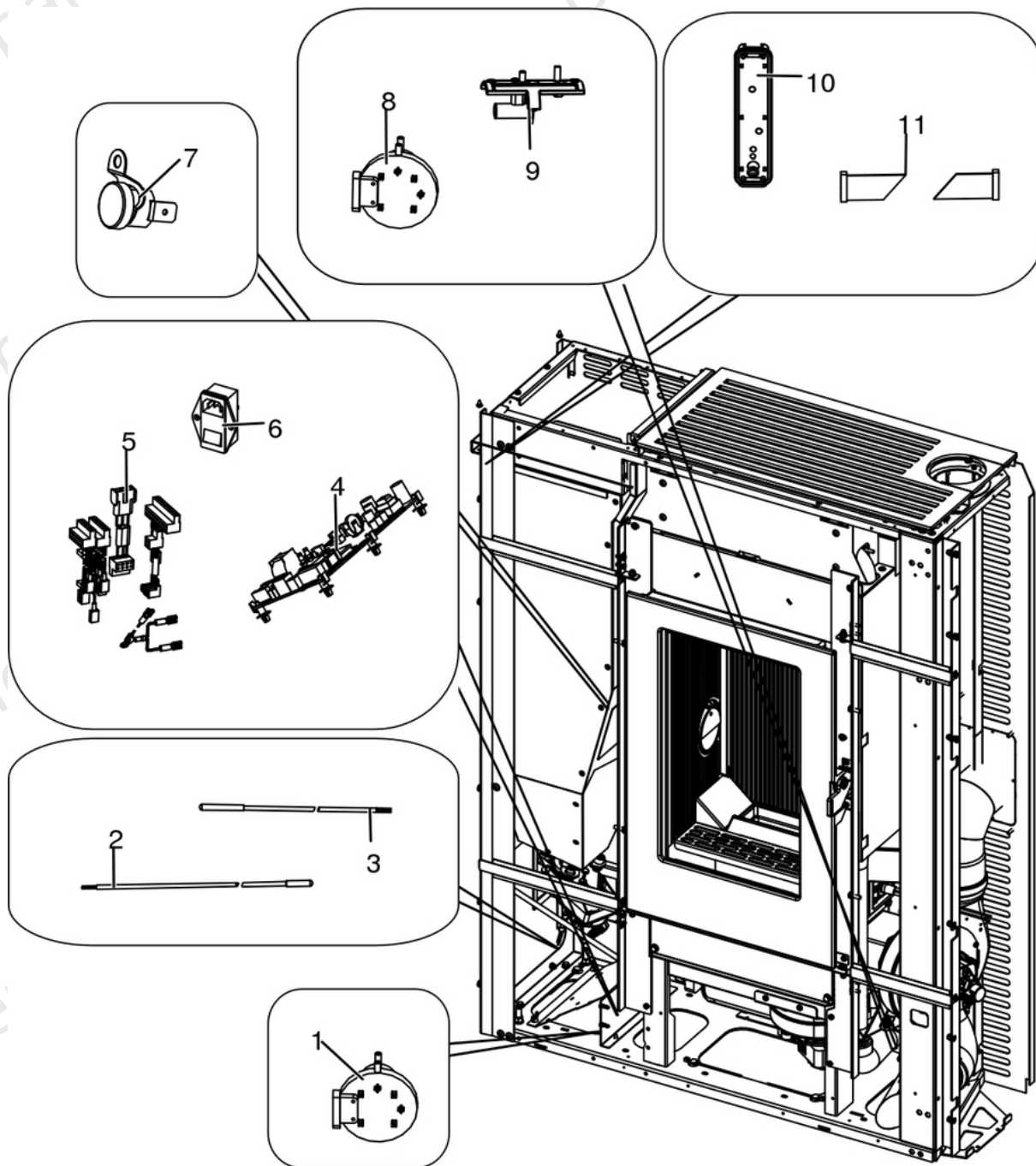

N°	Codice/Code	Descrizioni / Description / Beschreibung / Description / Description
1	41451303400	Trasduttore di pressione / Pressure transducer / Active-Wandler / Transducteur de pression / Transductor de pression
1	4120631A	Tubicino siliconico - 5m / Silicon tube - 5m / Silikonrohr - 5m / Petit tuyau en silicone - 5m / Tubo silicónico - 5m
2	41451703600	Sonda fumi con flangia con morsettiera L.980 / Smoke sensor with flange with terminal board L.980 / Rauchsonde mit Flansche mit Klemmenbrett L.980 / Sonde fumées avec bride avec serre-câble L.980 / Sonda humos con brida con borne L.980
3	4160386	Sonda temperatura ambiente/acqua / Room/Water temperature sensor / Raum- Wassertemperaturfühler / Sonde température ambiance/eau / Sonda temperatura ambiente/agua

<b>4</b>	<b>41451802200</b>	Scheda elettronica MAESTRO / Electronic board MAESTRO / Elektronische Platine MAESTRO / Carte électronique MAESTRO / Tarjeta electronica MAESTRO
<b>5</b>	<b>41451801000</b>	Cablaggio / Wiring / Verdrahtung / Cablage / Cableado
<b>5</b>	<b>41452000500</b>	Cavo motoriduttore / Reduction motor cable / Kabel Getriebemotor / Câble motoréducteur / Cable motorreductor
<b>6</b>	<b>4160193</b>	Pulsante accensione / On/Off button / Zündungstaste / Touche d'allumage / Botón encendido
<b>6</b>	<b>41451104100</b>	Presa con fusibile / Socket with fuse / Steckdose mit Sicherung / Prise avec fusible / Toma con fusible
<b>7</b>	<b>412007004</b>	Clickson 110°C / Clickson 110°C / Clickson 110°C / Clickson 110°C / Clickson 110°C
<b>8</b>	<b>41451003700</b>	Pressostato / Pressure switch / Druckschalter / Pressostat / Presostato
<b>8</b>	<b>4120631A</b>	Tubicino siliconico - 5m / Silicon tube - 5m / Silikonrohr - 5m / Petit tuyau en silicone - 5m / Tubo silicónico - 5m
<b>9</b>	<b>41601301851</b>	Componente rilevamento portata aria / Air flow measure component / Bauteil für Messung der Luftmenge / Composent pour la mesuration de la quantité d'air / Componente por la medida de l'aire
<b>9</b>	<b>4120631A</b>	Tubicino siliconico - 5m / Silicon tube - 5m / Silikonrohr - 5m / Petit tuyau en silicone - 5m / Tubo silicónico - 5m
<b>10</b>	<b>41451602802</b>	Pannello di emergenza Wireless / Wireless emergency display / Wireless Notfall-Blende / Panneau d'urgence wireless / Panel emergencia wireless
<b>11</b>	<b>41451801600</b>	Cavo flat 20 vie L.600 mm / Flat cable 20 pin L.600 mm / Flat-Kabel 20polig L.600 mm / Cable flat 20 voies L.600 mm / Flat cable 20 vias L.600 mm



## RAY COMFORT AIR 8 UP! M1 UNTIL S/N 1906260060004

Gruppo elettrico ed elettronico dal SN 2102240060030 / Electrical and electronic group starting from SN 2102240060030 / Elektrische und elektronische Gruppe ab SN 2102240060030 / Groupe électrique et électronique à partir du NS 2102240060030 / Grupo eléctrico y electrónico a partir de NS 2102240060030

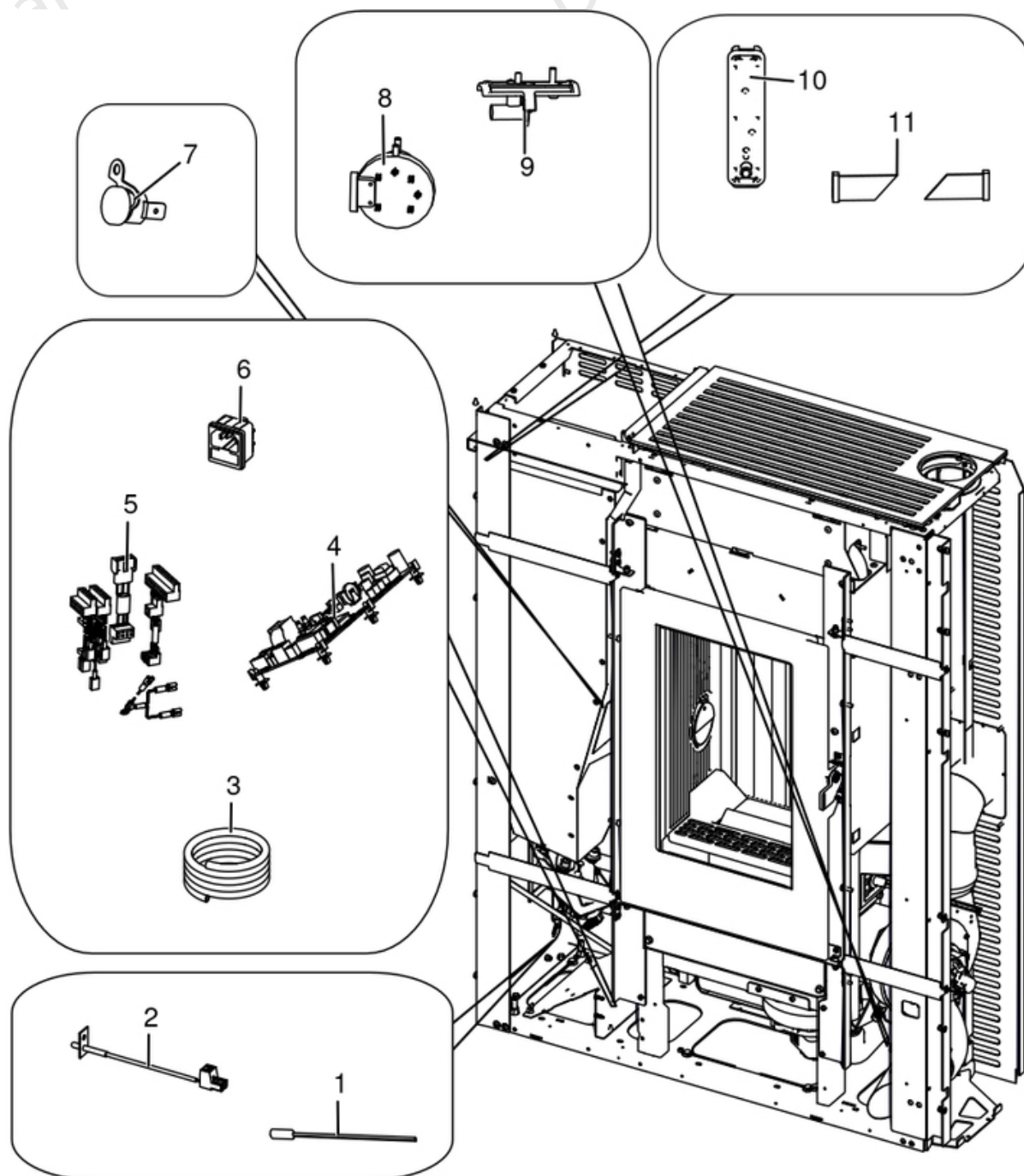

N°	Codice/Code	Descrizioni / Description / Beschreibung / Description / Descripcion
1	4160386	Sonda temperatura ambiente/acqua / Room/Water temperature sensor / Raum- Wassertemperaturfühler / Sonde température ambiance/eau / Sonda temperatura ambiente/agua
2	41451703600	Sonda fumi con flangia con morsettiera L.980 / Smoke sensor with flange with terminal board L.980 / Rauchsonde mit Flansche mit Klemmenbrett L.980 / Sonde fumées avec bride avec serre-câble L.980 / Sonda humos con brida con borne L.980
3	41801902500	Spirale Rilsan (30 m.) / Rilsan spiral (30 m.) / Spirale Rilsan (30 M.) / Spirale Rilsan (30 m.) / Espiral Rilsan (30 m.)
3	41801902500A	Spirale Rilsan (5 spire) / Rilsan spiral (5 coils) / Spirale Rilsan (5 Windungen) / Spirale Rilsan (5 spires) / Espiral Rilsan (5 espire)
4	41451904300	Scheda madre MAESTRO / Motherboard MAESTRO / Hauptplatine MAESTRO / Carte mère MAESTRO / Tarjeta madre MAESTRO
4	41451904300A	Sensirion / Sensirion / Sensirion / Sensirion / Sensirion
5	41451904901	Cablaggio / Wiring / Kabelbaum / Cablage / Cableado
5	41452000500	Cavo motoriduttore / Reduction motor cable / Kabel Getriebemotor / Câble motoréducteur / Cable motorreductor
6	41451104100	Presa con fusibile / Socket with fuse / Steckdose mit Sicherung / Prise avec fusible / Toma con fisible
7	412007004	Clickson 110°C / Clickson 110°C / Clickson 110°C / Clickson 110°C / Clickson 110°C
8	41451003700	Pressostato / Pressure switch / Druckschalter / Pressostat / Presostato
8	4120631A	Tubicino silicónico - 5m / Silicon tube - 5m / Silikonrohr - 5m / Petit tuyau en silicone - 5m / Tubo silicónico - 5m
9	41601301851	Componente rilevamento portata aria / Air flow measure component / Bauteil für Messung der Luftmenge / Composent pour la mesuration de la quantité d'air / Componente por la medida de l'aire
10	41451602802	Pannello di emergenza Wireless / Wireless emergency display / Wireless Notfall-Blende / Panneau d'urgence wireless / Panel emergencia wireless
11	41451801600	Cavo flat 20 vie L.600 mm / Flat cable 20 pin L.600 mm / Flat-Kabel 20polig L.600 mm / Cable flat 20 voies L.600 mm / Flat cable 20 vias L.600 mm

## RAY COMFORT AIR 8 UP! M1 UNTIL S/N 1906260060004

Gruppo fumi - Uscita Maschio / Smoke group - Male exit / Männlicher Rauchabzug / Groupe de fumées - sortie mâle / Grupo de humos - Flacha macho

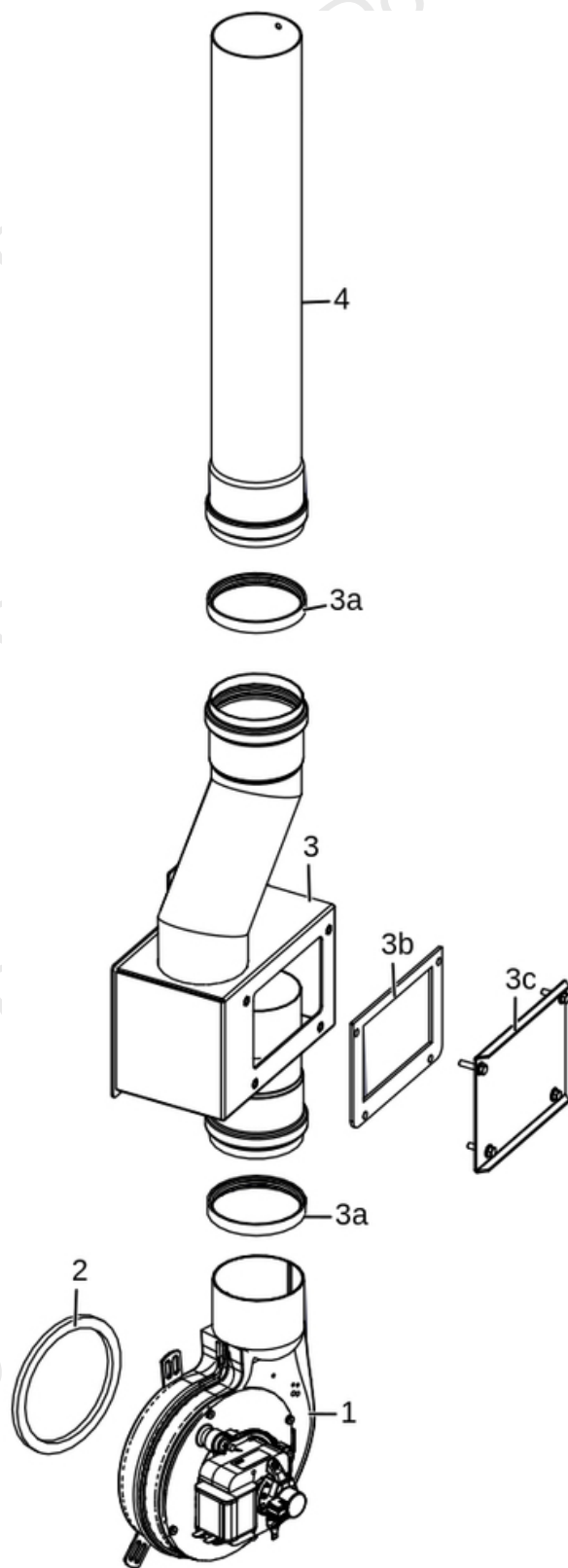

N°	Codice/Code	Descrizioni / Description / Beschreibung / Description / Descripcion
1	41451406501	Ventilatore fumi / Smoke exhausted fan / Rauchgasgebläse / Ventilateur fumées / Ventilador humos
1	41451209300	Encoder per ventilatore fumi marchi LN2/SIT / Encoder for LN2/SIT smoke fan / Encoder für LN2/SIT Rauchgasgebläse / Encoder pour ventilateur des fumées marques LN2/SIT / Encoder para ventilador humos marcas LN2/SIT
2	41801002600	Guarnizione adesiva voluta fumi / Adhesive gasket smoke volute / Haftendichtung Rauchvolute / Joint adhesive volute fumées / Junta adhesiva voluta humos
2	41801599850	Kit 50 guarnizioni / Kit 50 gaskets / Bausatz 50 Dichtungen / Kit 50 joints / Kit 50 juntas
3	41411800251	Scatola fumi / Fumes box / Rauchabzug / boîte à fumée / Caja humos
3a	40120969	Guarnizione silicone (5pz) / Silicone Gasket (5pc.) / Silikondichtung (5 St.) / Joint en silicone / Junta en silicona
3b	41801702000	Guarnizione scatola / Box gasket / Gehäuse Dichtung / Joint de boite / Burlete caja
3c	41401800430	Tappo scatola fumi / Plug fume box / Klappe Rauchabzug / Clapet boîte à fumée / Tapon caja de humos
4	40160464	Tube 8 L.50 / Tube 8 L.50 / Rohr 8 L.50 / Tuyau 8 L.50 / Tubo 8 L50

**RAY COMFORT AIR 8 UP! M1 UNTIL S/N 1906260060004**

Gruppo fumi - Uscita Femmina / Smoke group - Female exit / Rauchabzugsmuffe / Groupe de fumées - sortie femelle / Gruppo fumi - Flacha hembra

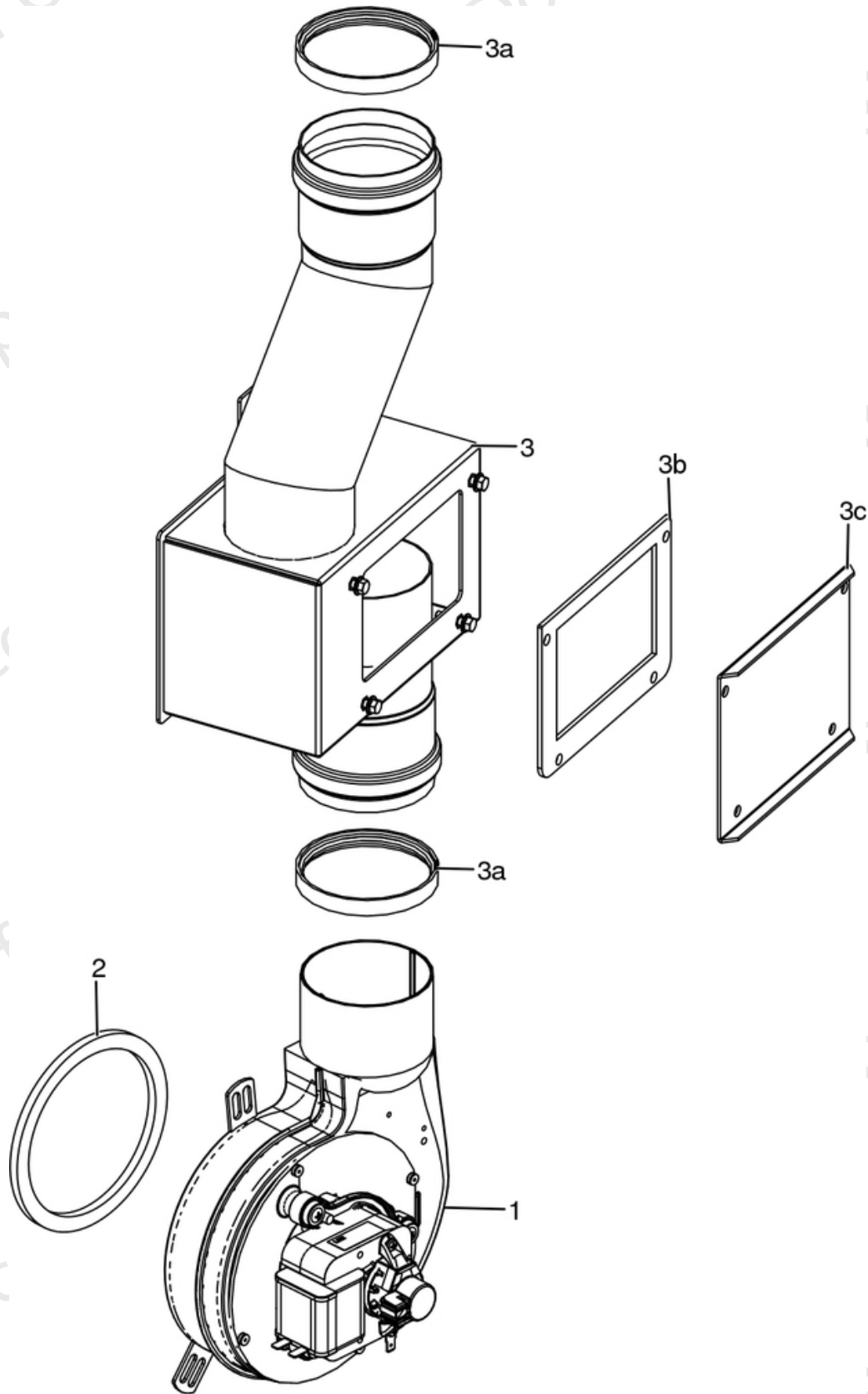

N°	Codice/Code	Descrizioni / Description / Beschreibung / Description / Descripción
1	41451406501	Ventilatore fumi / Smoke exhausted fan / Rauchgasgebläse / Ventilateur fumées / Ventilador humos
1	41801002600	Guarnizione adesiva voluta fumi / Adhesive gasket smoke volute / Haftendichtung Rauchvolute / Joint adhesive volute fumées / Junta adhesiva voluta humos
1	41451209300	Encoder per ventilatore fumi marchi LN2/SIT / Encoder for LN2/SIT smoke fan / Encoder für LN2/SIT Rauchgasgebläse / Encoder pour ventilateur des fumées marques LN2/SIT / Encoder para ventilador humos marcas LN2/SIT
1	41452009200	Encoder per ventilatore fumi marchio EMC / Encoder for EMC smoke fan / Encoder für EMC Rauchgasgebläse / Encoder pour ventilateur des fumées marque EMC / Encoder para ventilador humos marca EMC
2	41801002600	Guarnizione adesiva voluta fumi / Adhesive gasket smoke volute / Haftendichtung Rauchvolute / Joint adhesive volute fumées / Junta adhesiva voluta humos
2	41801599850	Kit 50 guarnizioni / Kit 50 gaskets / Bausatz 50 Dichtungen / Kit 50 joints / Kit 50 juntas
3	41411800251	Scatola fumi / Fumes box / Rauchabzug / boîte à fumée / Caja humos
3a	40120969	Guarnizione silicone (5pz) / Silicone Gasket (5pc.) / Silikondichtung (5 St.) / Joint en silicone / Junta en silicona
3b	41801702000	Guarnizione scatola / Box gasket / Gehäuse Dichtung / Joint de boîte / Burlete caja
3c	41401800430	Tappo scatola fumi / Plug fume box / Klappe Rauchabzug / Clapet boîte à fumée / Tapon caja de humos



## RAY COMFORT AIR 8 UP! M1 UNTIL S/N 1906260060004

Gruppo ventilazione / Ventilation group / Lüftungsgruppe / Groupe de ventilation / Grupo de ventilación

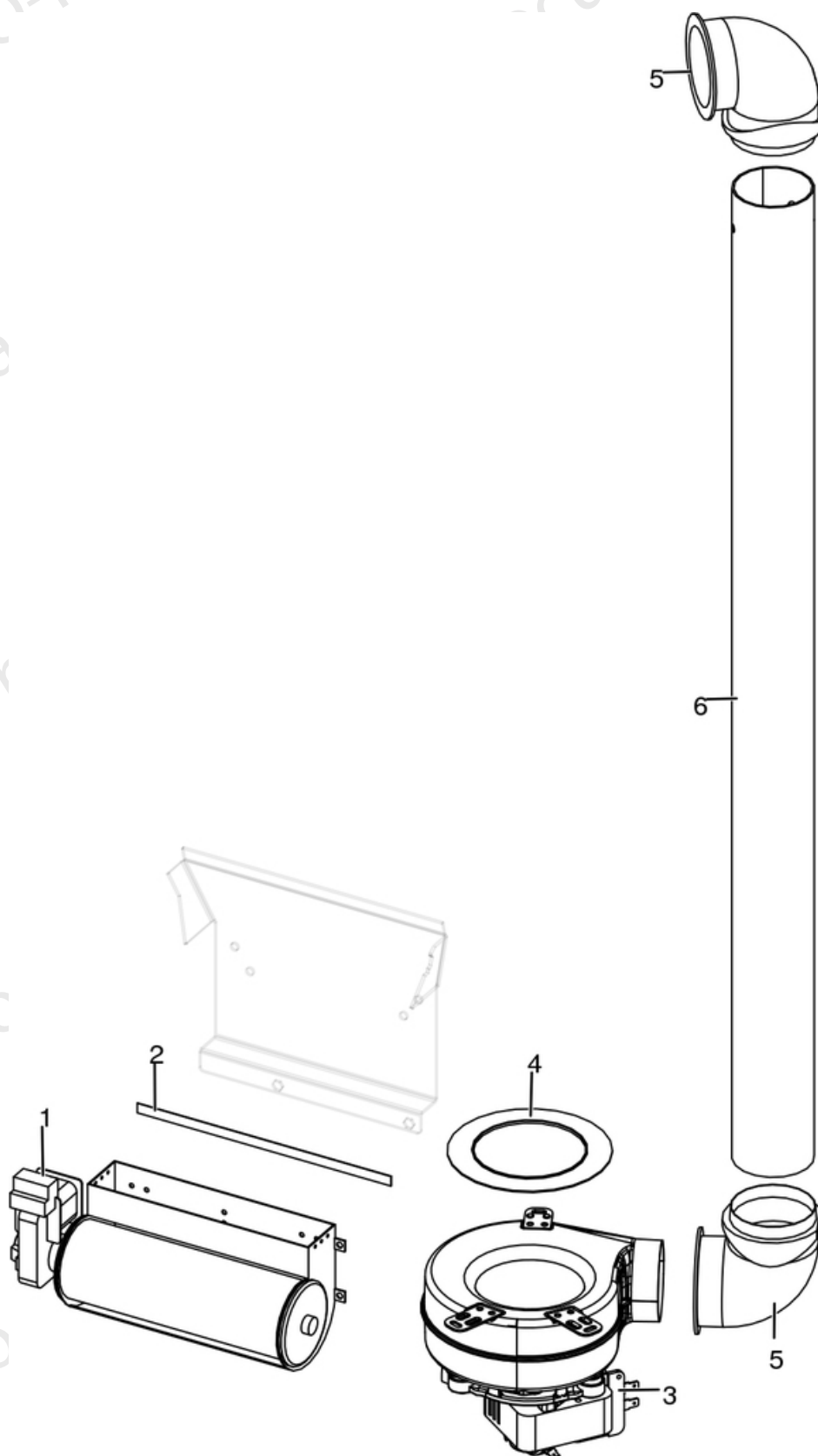

N°	Codice/Code	Descrizioni / Description / Beschreibung / Description / Descripcion
1	41451800900	Ventilatore tangenziale / Warm air fan / Luftgebläse / Ventilateur air / Ventilador aire
2	4120573A	Guarnizione a nastro 8 mm (5 mt.) per porta / Door strip gasket 8 mm (5 m) / Türbanddichtung 8 mm (5 m) / Joint ruban 8 mm (5 m) pour porte / Guarnición de cinta para puerta 8 mm (5 m)
2	4120573B	Guarnizione a nastro 8 mm (50 mt.) per porta / Door strip gasket 8 mm (50 m) / Türbanddichtung 8 mm (50 m) / Joint ruban 8 mm (50 m) pour porte / Guarnición de cinta para puerta 8 mm (50 m)
3	41451503300	Ventilatore centrifugo / Air fun / Luftgebläse / Ventilateur air / Ventilador aire
4	41801601600	Guarnizione ventilatore / Fan gasket / Dichtung des Gebläses / Joint du ventilateur / Junta ventilador
5	41601003600	Tubo 90° / Pipe 90° / Rohr 90° / Tuyau 90° / Tubo 90°
6	41601703160	Tubo aria Ø 60 lungo zincato / Long zinc-coated air pipe Ø 60 / Lang verzinkter Luftrohr Ø 60 / Tuyau air galvanisé long Ø 60 / Tubo aire cincado largo Ø 60

**RAY COMFORT AIR 8 UP! M1 UNTIL S/N 1906260060004**

Gruppo aria comburente / Combustion air group / Verbrennungsluft Gruppe / Groupe air comburant / Grupo aire comburente

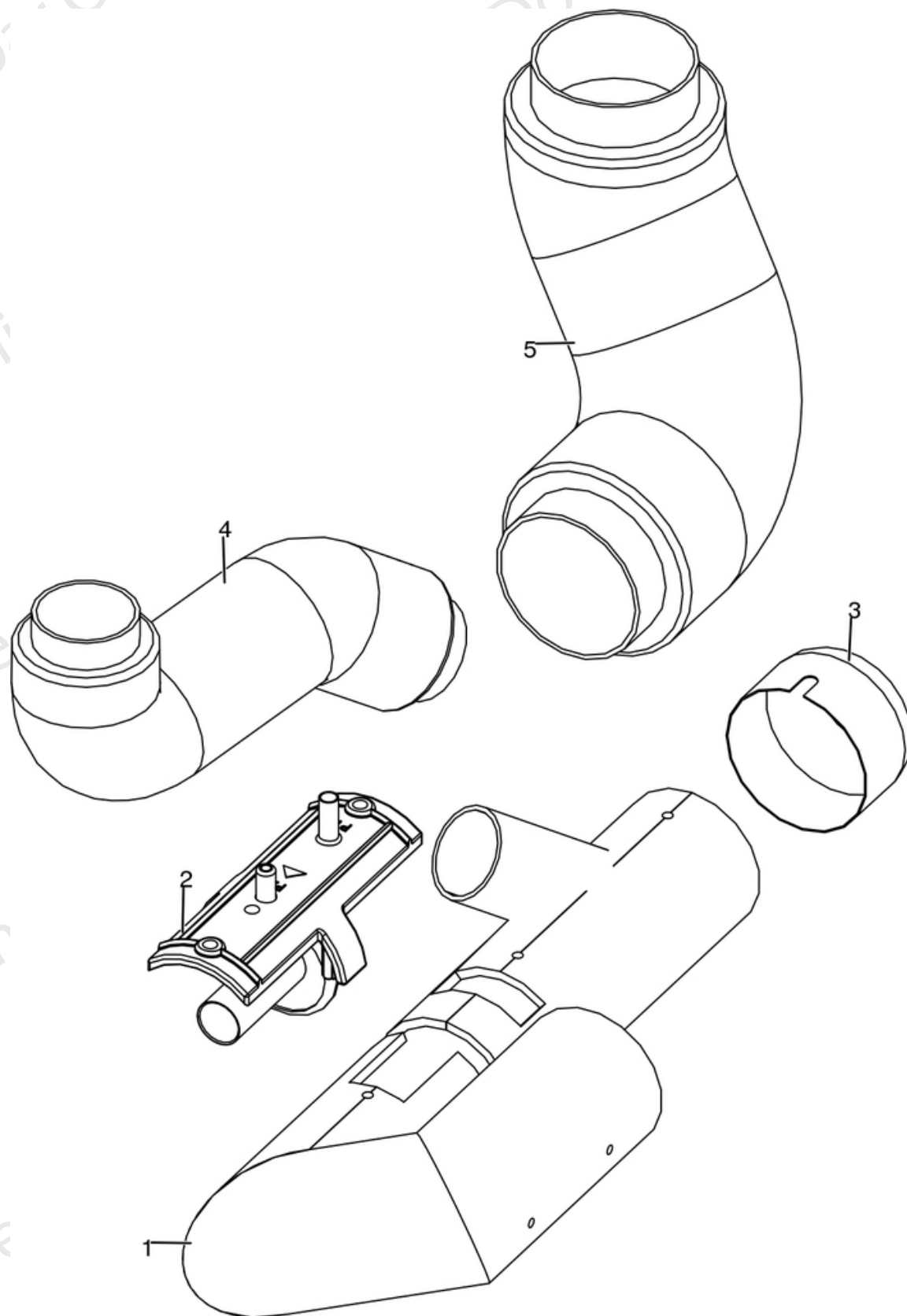

N°	Codice/Code	Descrizioni / Description / Beschreibung / Description / Descripción
1	41601703360	Tubo aspirazione zincato / Zinc-coated air inlet pipe / Verzinkt Lufteingangsrohr / Tuyau entrée d'air galvanisé / Tubo entrada aire cincado
2	41601301851	Componente rilevamento portata aria / Air flow measure component / Bauteil für Messung der Luftmenge / Composent pour la mesuration de la quantité d'air / Componente por la medida de l'aire
3	41401036100	Filtro antipolvere / Anti-dust filter / Staubschutzfilter / Filtre antipoussière / Filtro de protección polvo
4	41801601900	Tubo aspirazione pulizia vetro / Inlet pipe for cleaning glass air / Glasreinigungs Lufteingangsrohr / Tuyau entrée pour l'aire de nettoyage du vitre / Tubo entrada por l'aire de limpieza vidrio
5	41801601700	Tubo aspirazione camera combustione / Combustion chamber aspiration tube / Verbrennungskammer Förderrohr / Tuyau aspiration air chambre de combustion / Tubo aspiración aire cámara de combustión