

MCZ GROUP

MUSA COMFORT AIR 14 UP! M1

Gruppo estetico / Aesthetic group / Aesthetische Gruppe / Groupe esthétique / Grupo estético

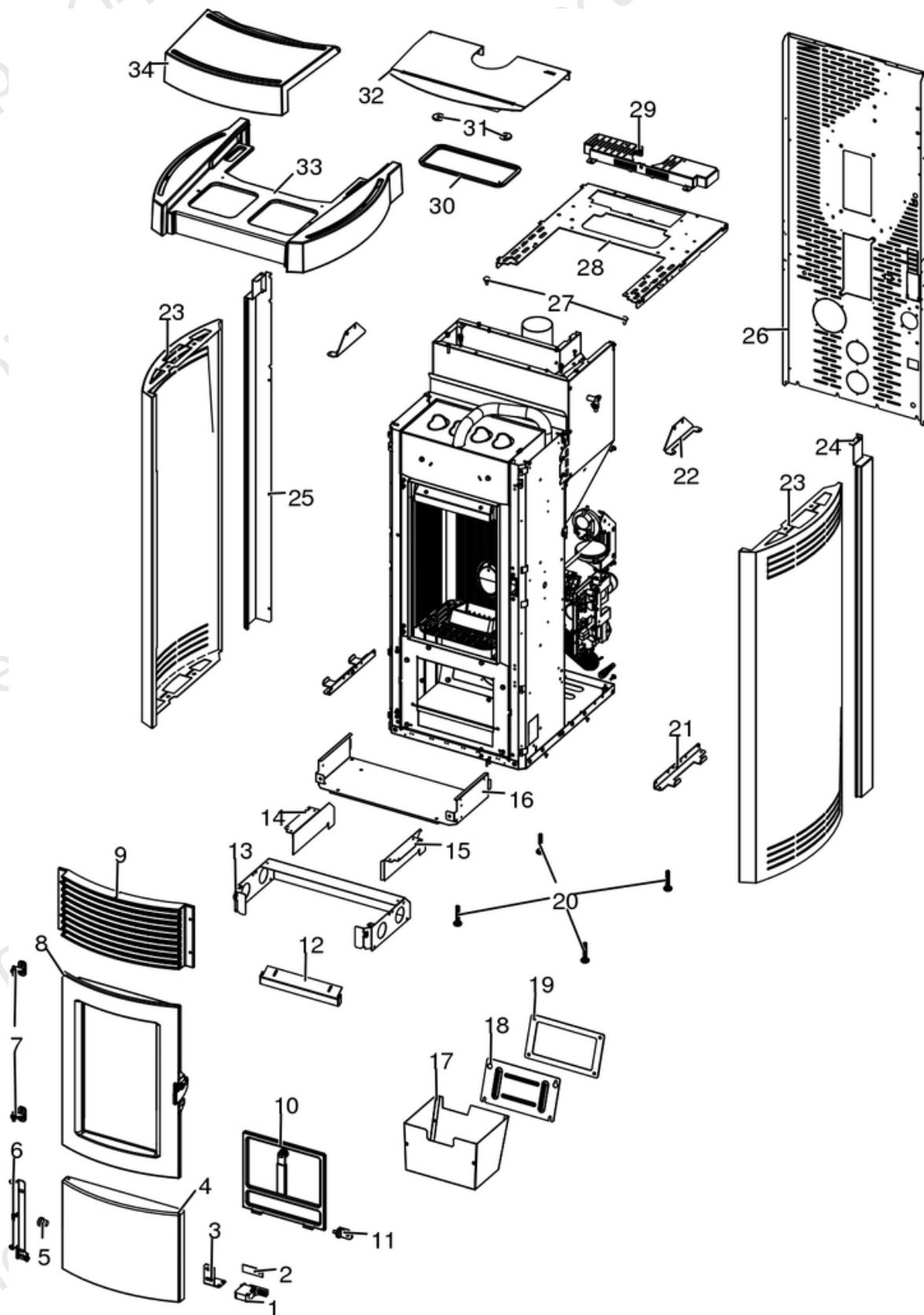

N°	Codice/Code	Descrizioni / Description / Beschreibung / Description / Descripcion
1	41201305100	Chiusura a spinta / Push-pull pressure closing / Druckschließung / Fermeture par pression / Cierre a presión
2	41801607300	Guarnizione scroccchetto / Latch gasket / Riegel Dichtung / Joint loquet / Burlete pestillo
3	41401632030	Staffa di supporto / Support bracket / Haltebügel / Étrier support / Abrazadera de soporte
4	41301503000V	Pannello inferiore in ghisa / Lower cast iron tile / Unteres Paneel aus Gusseisen / Panneau inférieur en fonte / Panel inferior en arrabio
5	4120180	Gommini paracolpi (4 pz) / Rubber bumpers (4 pcs.) / Schlagschutzgummi (4 Stck) / Pièces caoutchouc antichoc (4 pcs) / Cauchitos anti-golpes (4 pz)
6	41411668640V	Supporto sportello / Door brakel / Türträger Klappe / Etrier porte / Soporte puerta
7	41201504460	Cerniera porta (2 pz.) / Door hinge (2 pc.) / Tür Scharnier (2 Stk.) / Charnière porte (2 pc.) / Bisagra puerta (2)
8	437016208	Porta / door / Tür / Porte / Puerta
9	41301503100V	Griglia aria superiore in ghisa / Upper cast iron air grille / Obere Luftgitter aus Guß / Grille air supérieur en fonte / Rejilla aire superior de arrabio
10	437016130	Porta cenere con maniglia / Ash drawer door with handle / Tür des Aschenkastens mit Griff / Porte tiroir à cendres avec poignée / Puerta cajón ceniza con tirador
11	41411674540V	Supporto sportello cenere / Ash drawer support / Aschenkasten Stütze / Support tiroir à cendres / Soporte Cajón ceniza
12	41411615430V	Deflettore aria / Air deflector / Luftleitblech / Déflecteur aire / Deflector aire
13	41401721830	Convogliatore / Conveyor / Blech / Convoyeur / Conductor
14	41401626131V	Tamponazione sx / L. filling / Abdichtung L. / Tampon G. / Taponado IZDO
15	41401626031V	Tamponazione dx / R. filling / Abdichtung R. / Tampon D. / Taponado DCHO
16	41401626232V	Compensatore / Compensator / Kompensator / Compensateur / Compensador
17	437016041	Cassetto cenere / Ash drawer / Aschenkasten / Tiroir à cendres / Cajón ceniza
18	41401339610	Tappo ispezione vano fumi / Smoke compartment inspection plug / Inspektionsdeckel Rauchabzug / Clapet inspection compartiment fumées / Tapón inspección compartimento humos
19	41800900600	Guarnizione / Gasket / Dichtung / Joint / Junta
19	41801599750	Kit 50 guarnizioni / Kit 50 gaskets / Bausatz 50 Dichtungen / Kit 50 joints / Kit 50 juntas
20	41200906660	Piedini di appoggio (4 pz.) / Support feet (4 pcs.) / Einstellfüße (4 Stck.) / Vérins d'appui (4 p.es) / Pies de apoyo (4 piezas)
21	41401629030	Supporto fianco / Side support / Seitenträger / Support côté / Soporte lateral
22	41401628930	Supporto fianco / Side support / Seitenträger / Support côté / Soporte lateral
23	6916011	Rivestimento completo Metal White / Metal White complete cladding / Metal White komplette Verkleidung / Habillage complet Metal White / Revestimiento completo Metal White
23	6916012	Rivestimento completo Metal Silver / Metal Silver complete cladding / Metal Silver komplette Verkleidung / Habillage complet Metal Silver / Revestimiento completo Metal Silver
23	6916013	Rivestimento completo Metal Black / Metal Black complete cladding / Metal Black komplette Verkleidung / Habillage complet Metal Black / Revestimiento completo Metal Black
23	6916014	Rivestimento completo Metal Bordeaux / Metal Bordeaux complete cladding / Metal Bordeaux komplette Verkleidung / Habillage complet Metal Bordeaux / Revestimiento completo Metal Bordeaux
24	41411674230P	Spalla DX / R. Pillar / Re. Säule / Pilier D. / Pilar DCHO
25	41411674330P	Spalla SX / L. Pillar / Li. Säule / Pilier G. / Pilar IZDO
26	41401631034	Schiena serbatoio / Rear back / Rückwand / Dos du réservoir / Espalda de depósito
27	41801002300	Paracolpi in silicone Ø 8/5 (2pz) / Silicone bumpers Ø 8/5 (2pcs) / Schlagschutzgummi Ø 8/5 (2 Stck) / Pièces silicone antichoc Ø 8/5 (2pcs) / Anti-golpes en silicona Ø 8/5 (2pzs)
28	41401701731	Supporto top / Top support / Deckelhaltebügel / Support du dessus / Soporte top
29	41411715931V	Collare top / Top collar / Top Kragen / Col supérieur / Cuello tapa
30	41801601400	Guarnizione coperchio serbatoio / Pellet hopper cover gasket / Deckel Pelletbehälter Dichtung / Joint couvercle réservoir pellet / Junta tapa depósito pellet
31	41801657900	Magneti (pz.2) / Magnet (pcs.2) / Magnet (stk. 2) / Aimant (pcs.2) / Imán (pz.2)
32	41411876250	Coperchio completo / Complete cover / Kompletter Deckel / Couvercle complet / Tapa completa
32	41421608550	Coperchio completo / Complete cover / Kompletter Deckel / Couvercle complet / Tapa completa
32	41801701400	Logo MCZ / MCZ logo / MCZ logo / MCZ logo / MCZ logo
33	41301400560	Top in ghisa / Cast iron top / Topplatte aus Guß / Dessus en fonte / Top de arrabio
34	41301502900V	Frontalino superiore in ghisa / Cast iron upper panel / Obere Platte aus Guss / Plaque supérieure en fonte / Panel superior de arrabio

MUSA COMFORT AIR 14 UP! M1

Gruppo camera di combustione / Combustion chamber group / Verbrennungskammer Gruppe / Group de chambre de combustion / Grupo cámara de combustión

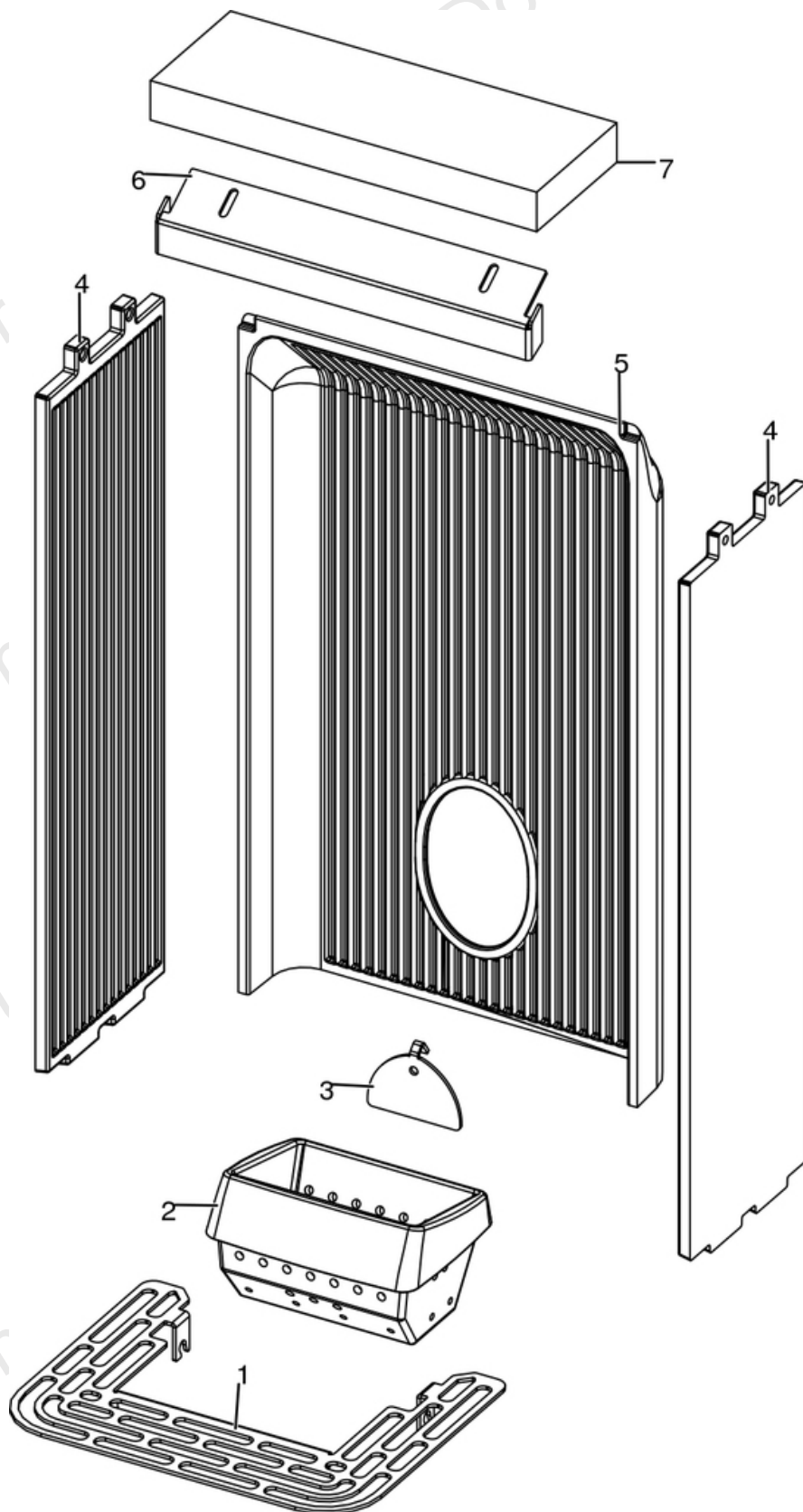

N°	Codice/Code	Descrizioni / Description / Beschreibung / Description / Descripcion
1	41411634830V	Griglia focolare / Fire Box Grille / Feuerstellenrost / Grille Foyer / Rejilla Hogar
2	41301502400V	Braciara ghisa / Cast iron grate / Brennertopf aus Gusseisen / Brasero en fonte / Brasero en arrabio
3	41411613530V	Deflettore pellet / Pellet deflector / Pellet Leitblech / Deflecteur pellet / Deflector pellet
4	41301502500V	Fianco ghisa / Cast iron side / Seite aus Guß / Côté en fonte / Placa lateral de arrabio
5	41301502600V	Schiena ghisa / Cast iron back / Rückwand aus Gusseisen / Dossieret en fonte / Parte trasera en arrabio
6	41411615430V	Deflettore aria / Air deflector / Luftleitblech / Déflecteur aire / Deflector aire
7	41151600200	Deflettore focolare in vermiculite / Vermiculite deflector / Leitblech aus Vermiculite / Déflecteur en vermiculite / Deflector en vermiculite

MUSA COMFORT AIR 14 UP! M1

Gruppo accensione / Ignition group / Entzündung Gruppe / Groupe d'allumage / Grupo ignición

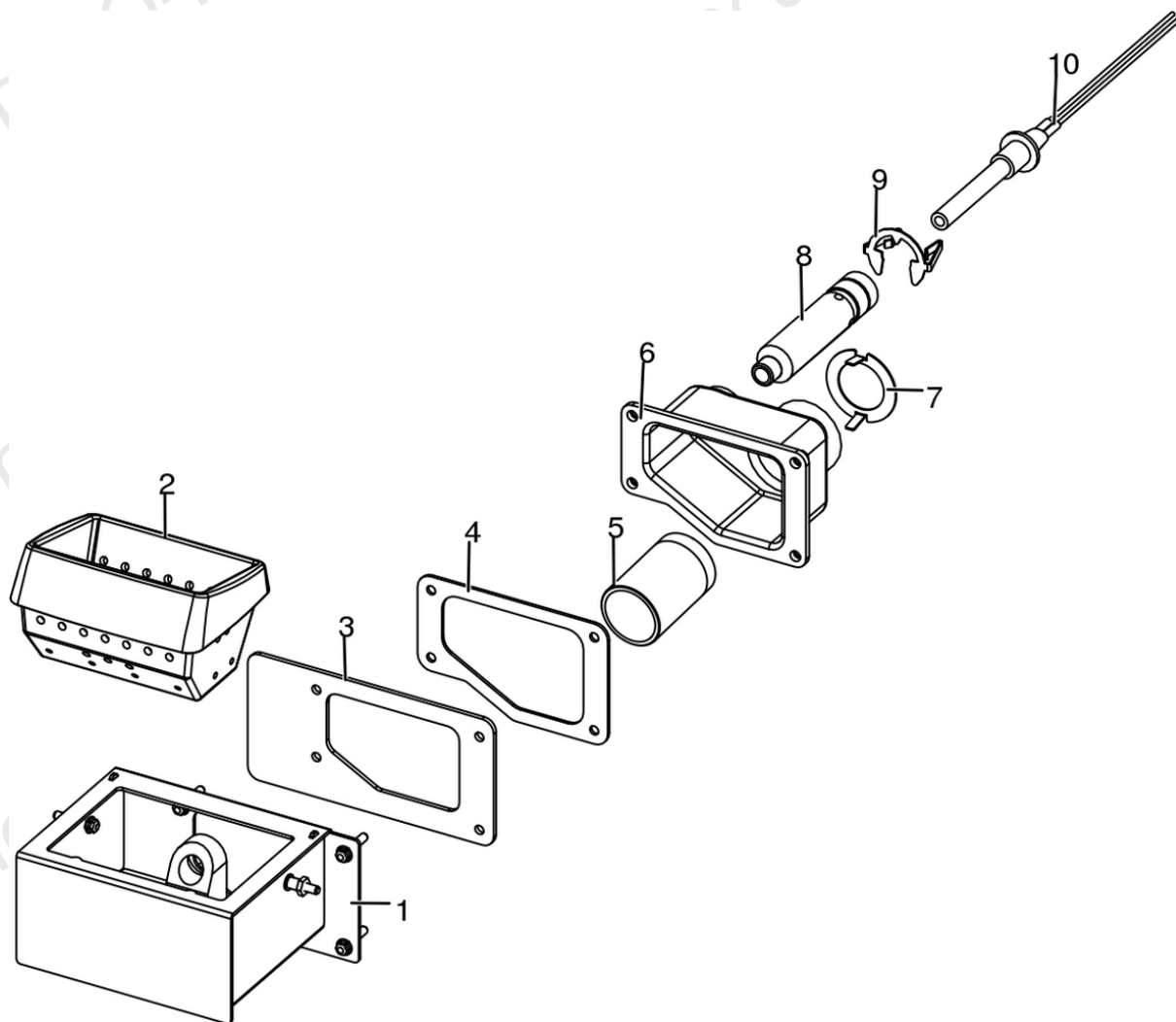

N°	Codice/Code	Descrizioni / Description / Beschreibung / Description / Descripción
1	41411613140V	Tasca braciere / Combustion pot container / Brenntopfkasten / Récipient brasero / Contenedor brasero
2	41301502400V	Braciere ghisa / Cast iron grate / Brennertopf aus Gusseisen / Brasero en fonte / Brasero en arrabio
3	41801601500	Guarnizione tasca braciere / Combustion pot container gasket / Brenntopfkasten Dichtung / Joint récipient brasero / Junta contenedor brasero
4	41801602300	Guarnizione codolo / Gasket / Dichtung / Joint / Junta
5	41501701599	Manicotto potenziamento accensione / Combustion air extension pipe / Zusatzrohr für Nachrüstung / Tuyau amélioration allumage / Tubo impulso de encendido
6	41311803500	Codolo / Tool chuck / Einspannschaft / Outil d'emmanchement / Mango
7	41401629410	Regolatore ingresso aria comburente / Combustion air intake adjuster / Regler Eingang Verbrennungsluft / Régulateur arrivée air comburant / Regulador entrada aire comburente
8	41601601000	Condotto candeledda / Sparkplug Conduit / Zündkerzenkanal / Conduit Bougie / Conducto Bujía
9	41201601500	Anello arresto candeledda / Sparkplug stop / Zündkerzestopper / Butée bougie / Tope bujía
10	41451308101	Candeledda 315 Watt / Sparkplug 315 Watt / Zündkerze 315 Watt / Bougie 315 Watt / Bujía 315 Watt
10	41451308150	Kit 25 candeledda 315 Watt / 25 Sparkplugs 315 Watt kit / Bausatz 25 Zündkerzen 315 Watt / Kit 25 Bougies 315 Watt / Kit 25 Bujías 315 Watt
10	41452009900	Candeledda 300 Watt / Sparkplug 300 Watt / Zündkerze 300 Watt / Bougie 300 Watt / Bujía 300 Watt

MUSA COMFORT AIR 14 UP! M1

Porta fuoco / Fire door / Feuertür / Porte foyer / Puerta hogar

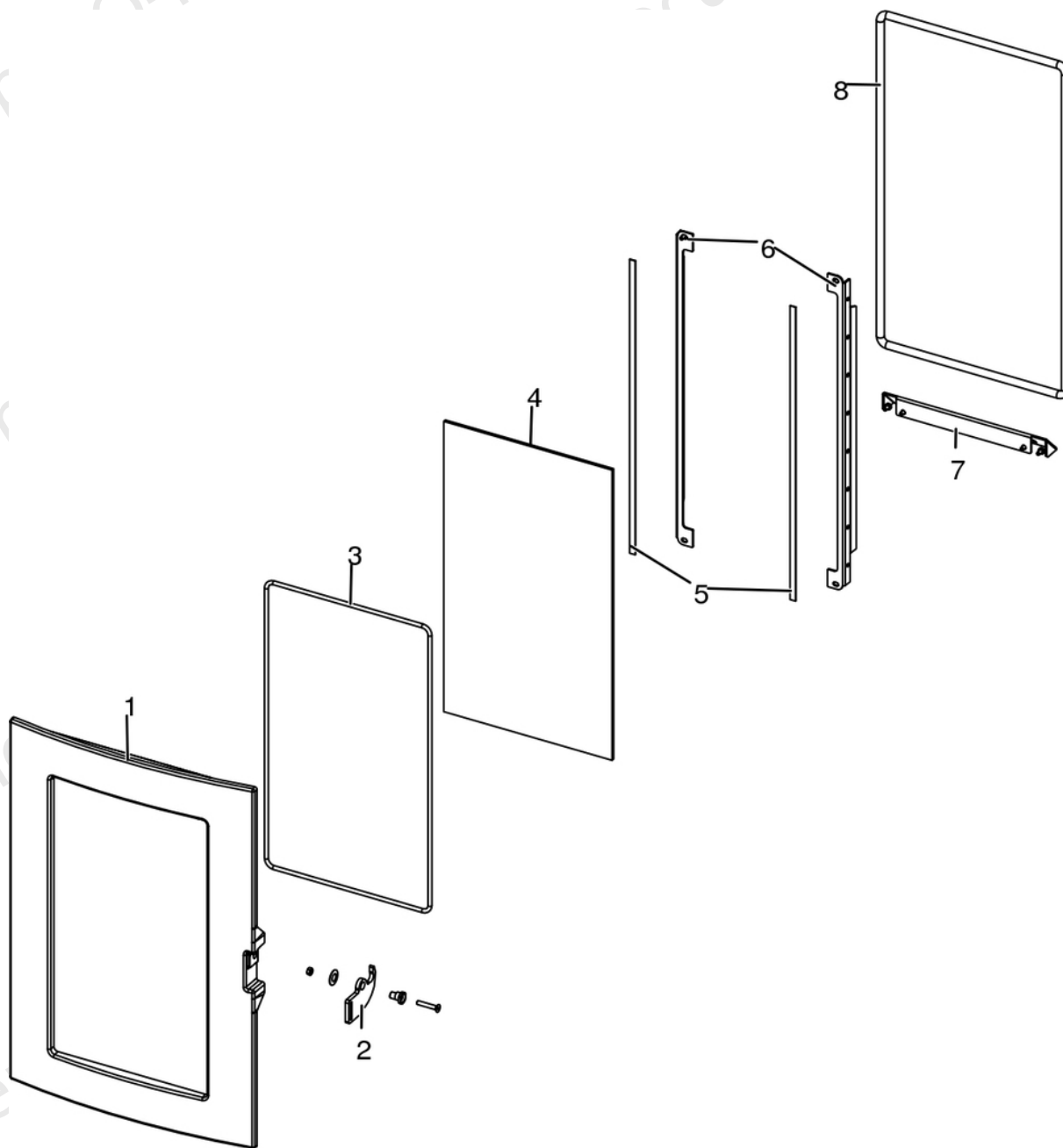

N°	Codice/Code	Descrizioni / Description / Beschreibung / Description / Descripción
1	41301600500V	Telaio porta fuoco in ghisa / Cast iron fire door frame / Feuertürrahment aus Guß / Cadre porte foyer en fonte / Armazón puerta hogar de arrabio
2	41401424160	Maniglia completa / Complete handle / Kompletter Griff / Poignée complète / Tirador completo
3	41801603300A	Guarnizione Ø5 5mt / Gasket Ø5 5mt / Dichtung Ø5 5mt / Joint Ø5 5mt / Junta Ø5 5mt
3	41801603300B	Guarnizione Ø5 50mt / Gasket Ø5 50mt / Dichtung Ø5 50mt / Joint Ø5 50mt / Junta Ø5 50mt
3	41801603300C	Guarnizione Ø5 5mt + silicone / Gasket Ø5 5mt + silic / Dichtung Ø5 5mt + Silikon / Joint Ø5 5mt + silic / Junta Ø5 5mt
4	41701600300	Vetroceramico porta ghisa / Cast iron door glass / Glaskeramikscheibe Tür aus Gusseise / Vitrocéremique porte en fonte / Cristal cerámico puerta en arrabio
5	4120573A	Guarnizione a nastro 8 mm (5 mt.) per porta / Door strip gasket 8 mm (5 m) / Türbanddichtung 8 mm (5 m) / Joint ruban 8 mm (5 m) pour porte / Guarnición de cinta para puerta 8 mm (5 m)
5	4120573B	Guarnizione a nastro 8 mm (50 mt.) per porta / Door strip gasket 8 mm (50 m) / Türbanddichtung 8 mm (50 m) / Joint

		ruban 8 mm (50 m) pour porte / Guarnición de cinta para puerta 8 mm (50 m)
6	41411622030V	Profilo fermavetro / Fastening bracket profile / Haltebügel für Scheibebefestigung Profil / Profil patte de fixation / Perfil fermacristal
7	41411622130V	Scivolo cenere / Ash ramp / Aschenrutsche / Glissèrie cendre / Tobogán ceniza
8	4120104A	Cordino fibrocaramico Ø 12 mm (5 mt.) / Ceramic fibre cord Ø 12 mm (5 m.) / Keramikfaserschnur Ø 12 mm (5 m) / Cordon en fibre céramique Ø 12 mm (5 m) / Junta a cuerda de fibra cerámica Ø 12 mm (5 m)
8	4120104B	Cordino fibrocaramico Ø 12 mm (50 mt.) / Ceramic fibre cord Ø 12 mm (50 m.) / Keramikfaserschnur Ø 12 mm (50 m) / Cordon en fibre céramique Ø 12 mm (50 m) / Junta a cuerda de fibra cerámica Ø 10 mm (52 m)
8	41201041	Kit sostituzione cordino (cordino+silicone) Ø 12 mm / Cord replacement kit (cord + silicon) Ø 12 mm / Schnuraustauschsatz (Schnur+Silikon) Ø 12 mm / Kit remplacement cordon (cordon + silicone) Ø 12 mm / Kit sustitución junta a cuerda (junta a cuerda+silicón) Ø 12 mm

MUSA COMFORT AIR 14 UP! M1

Gruppo caricamento pellet / Pellet feed group / Pellet Fördergruppe / Groupe chargement du pellet / Grupo de carga pellet

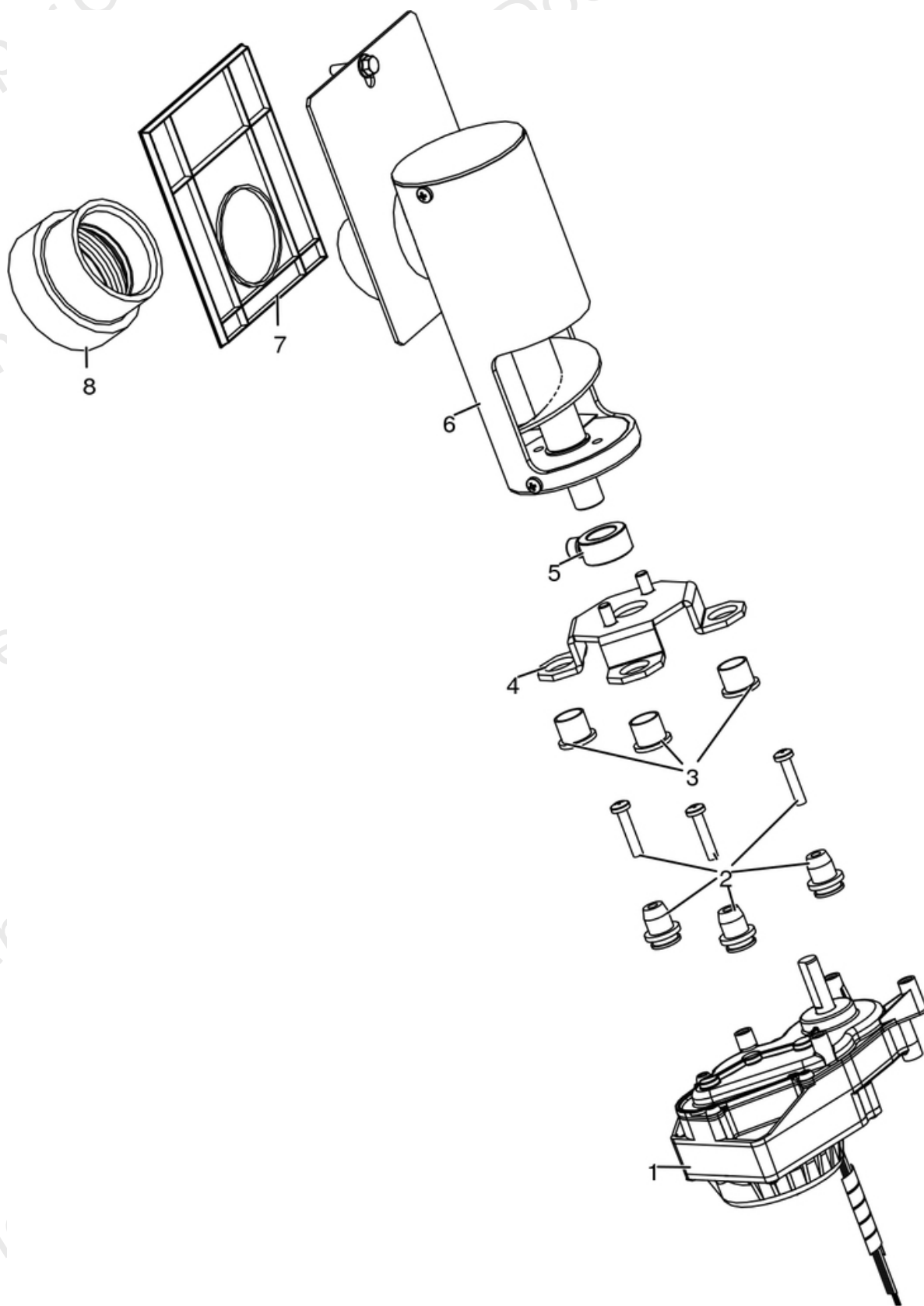

N°	Codice/Code	Descrizioni / Description / Beschreibung / Description / Descripción
1	41451702200	Motoriduttore brushless / Brushless reduction motor / Brushless Getriebemotor / Motoréducteur brushless / Motorreductor brushless
1	41452000500	Cavo motoriduttore / Reduction motor cable / Kabel Getriebemotor / Câble motoréducteur / Cable motorreductor
2	41801703700	Gommini antivibrante / Vibration damper rubber / Rammenschutz Gummi / Caoutchouc antivibratoire / Cauchitos antivibración
3	41201800700	Boccola (3 pz) / Bushing (3 pcs) / Buchse (3 Stk) / Douille (3 pcs) / Abrazadera (3 pzs)
4	41411779331	Supporto coclea "Ragno" / Pellet feed screw bracket "spider" / "Spinne" Schenke Gestell / Support vis sans fin "Araignée" / Sopoite coclea "Araña"
5	4120398	Connettore motoriduttore-coclea / Reduction motor-feed screw connector / Verbindung Getriebemotor-Schnecke / Connecteur motoréducteur-vis sans fin / Conector motorreductor-cóclea
6	41411800151	Gruppo alimentazione completo / Complete feed screw / Komplette Förderschnecke / Vis sans fin complète / Coclea de carga completa
7	41801600400	Guarnizione gruppo caricamento / Gasket / Dichtung / Joint / Junta
8	41801702600	Guarnizione / Gasket / Dichtung / Joint / Junta

MUSA COMFORT AIR 14 UP! M1

Porta cenere / Ash door / Ashentür / Porte cendre / Puerta ceniza

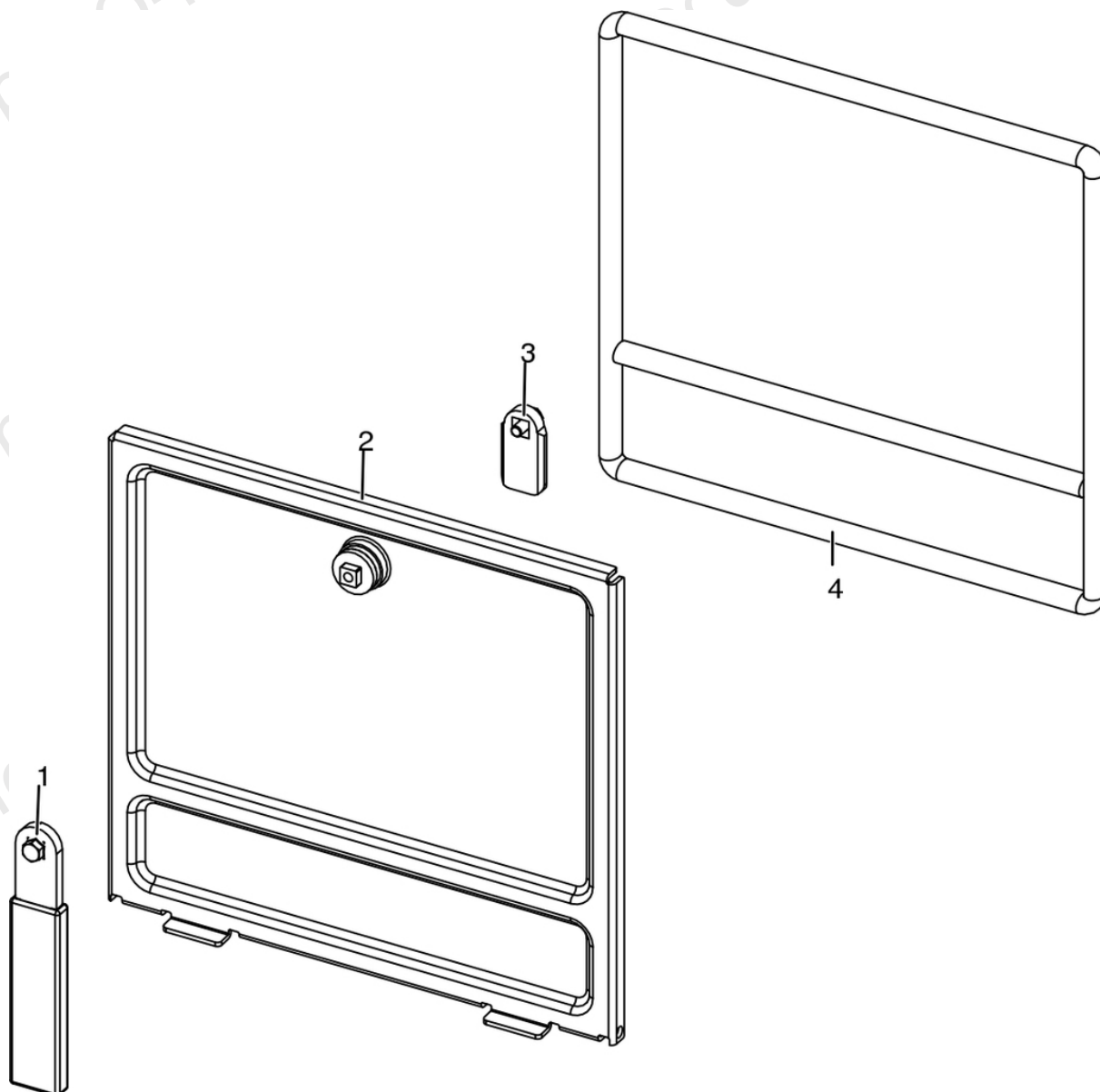

N°	Codice/Code	Descrizioni / Description / Beschreibung / Description / Description
1	41411621600	Maniglia con impugnatura porta cenere / Handle / Griff / Poignée / Tirador
2	41421602141V	Porta cenere / Ash drawer door / Tür des Aschenkastens / Porte tiroir à cendres / Puerta cajón ceniza
3	41201608400	Serratura porta cassetto cenere / Door lock for ash drawer / Türschloss für Aschenkasten / Serrure de porte du tiroir à cendres / Cerradura puerta cajón ceniza
4	412007003A	Cordino fibroceramico Ø 14 mm (5 mt.) / Ceramic fibre cord Ø 14 mm (5 m.) / Keramikfaserschnur Ø 14 mm (5 m) / Cordon en fibre céramique Ø 14 mm (5 m) / Junta a cuerda de fibra cerámica Ø 14 mm (5 m)
4	412007003B	Cordino fibroceramico Ø 14 mm (50 mt.) / Ceramic fibre cord Ø 14 mm (50 m.) / Keramikfaserschnur Ø 14 mm (50 m) / Cordon en fibre céramique Ø 14 mm (50 m) / Junta a cuerda de fibra cerámica Ø 14 mm (50 m)
4	412007003C	Kit sostituzione cordino (cordino+silicone) Ø 14 mm / Cord replacement kit (cord + silicon) Ø14 mm / Schnuraustauschsatz (Schnur +Silikon) Ø 14 mm / Kit remplacement cordon (cordon+silicon) Ø 14 / Kit sustitución junta a cuerda (junta a cuerda+silicón) Ø 14 mm

MUSA COMFORT AIR 14 UP! M1

Gruppo aria comburente / Combustion air group / Verbrennungsluft Gruppe / Groupe air comburant / Grupo aire comburente

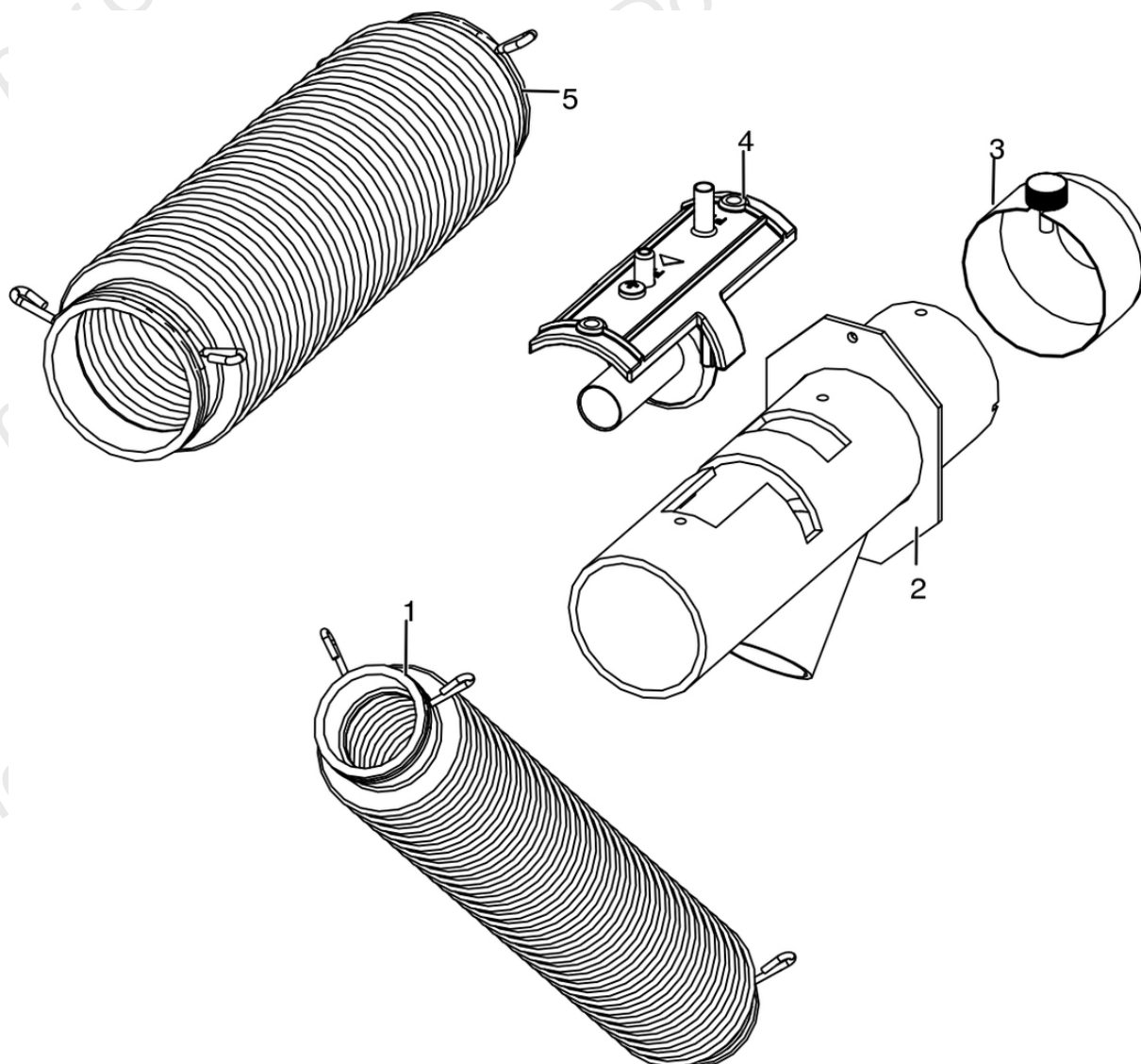

N°	Codice/Code	Descrizioni / Description / Beschreibung / Description / Descripción
1	41801601900	Tubo aspirazione pulizia vetro / Inlet pipe for cleaning glass air / Glassreinigungs Lufteingangrohr / Tuyau entrée pour l'aire de nettoyage du vitre / Tubo entrada por l'aire de limpieza vidrio
2	41601604461	Tubo aspirazione / Air inlet pipe / Lufteingangrohr / Tuyau entrée d'air / Tubo entrada aire
3	41401036100	Filtro antipolvere / Anti-dust filter / Staubschutzfilter / Filtre antipoussière / Filtro de protección polvo
4	41601301851	Componente rilevamento portata aria / Air flow measure component / Bauteil für Messung der Luftmenge / Composent pour la mesuration de la quantité d'air / Componente por la medida de l'aire
5	41801601700	Tubo aspirazione camera combustione / Combustion chamber aspiration tube / Verbrennungskammer Förderrohr / Tuyau aspiration air chambre de combustion / Tubo aspiración aire cámara de combustión

MUSA COMFORT AIR 14 UP! M1

Gruppo elettrico ed elettronico / Electrical and electronic group / Elektrische und elektronische Gruppe / Groupe électrique et électronique / Grupo eléctrico y electrónico

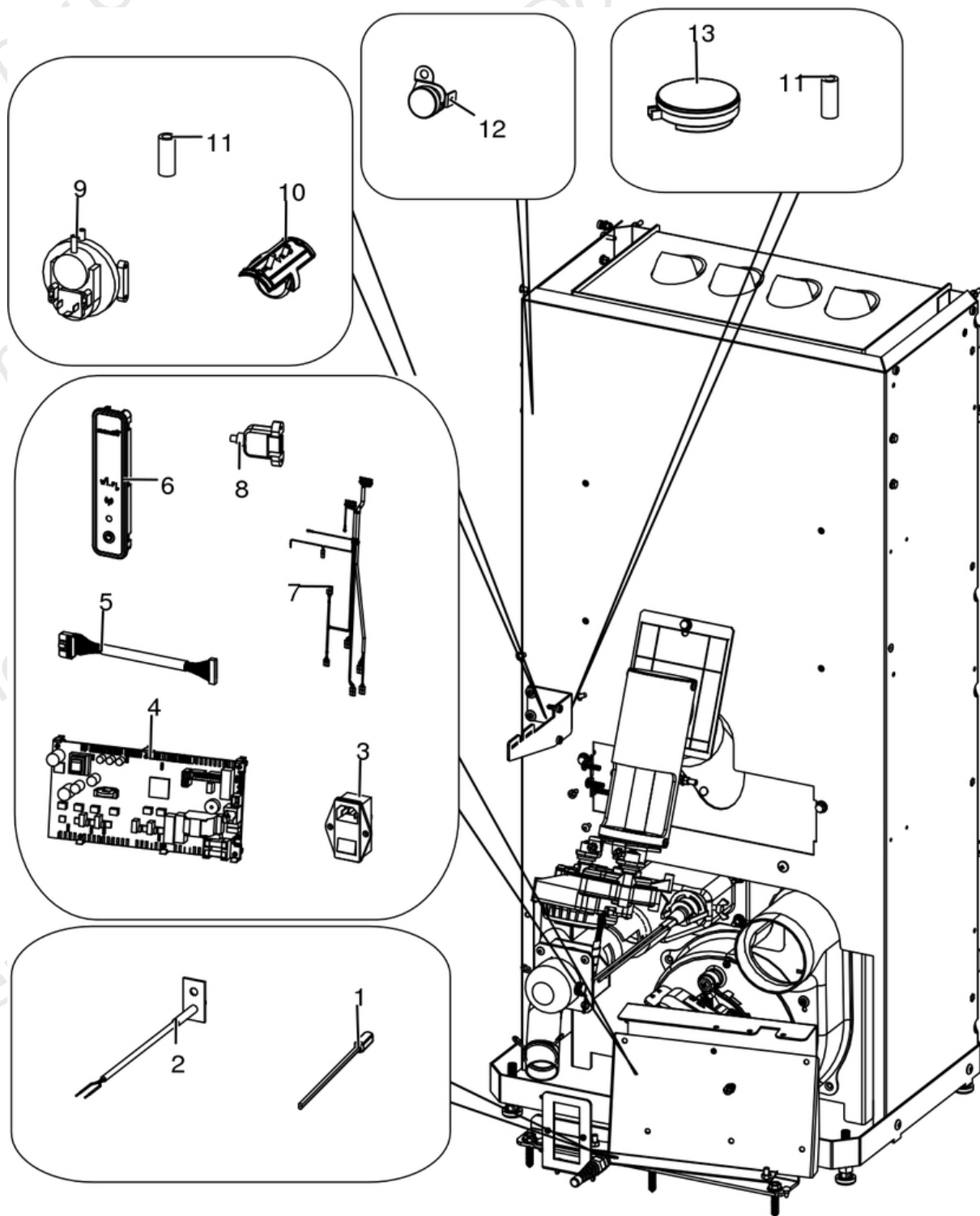

N°	Codice/Code	Descrizioni / Description / Beschreibung / Description / Descripción
1	4160386	Sonda temperatura ambiente/acqua / Room/Water temperature sensor / Raum- Wassertemperaturfühler / Sonde température ambiance/eau / Sonda temperatura ambiente/agua
2	41451703600	Sonda fumi con flangia con morsettiera L.980 / Smoke sensor with flange with terminal board L.980 / Rauchsonde mit Flansche mit Klemmenbrett L.980 / Sonde fumées avec bride avec serre-câble L.980 / Sonda humos con brida con borne L.980

3	4160193	Pulsante accensione / On/Off button / Zündungstaste / Touche d'allumage / Botón encendido
3	41451104100	Presca con fusibile / Socket with fuse / Steckdose mit Sicherung / Prise avec fusible / Toma con fusible
4	41451802200	Scheda elettronica MAESTRO / Electronic board MAESTRO / Elektronische Platine MAESTRO / Carte electronique MAESTRO / Tarjeta electronica MAESTRO
5	41451801600	Cavo flat 20 vie L.600 mm / Flat cable 20 pin L.600 mm / Flat-Kabel 20polig L.600 mm / Cable flat 20 voies L.600 mm / Flat cable 20 vias L.600 mm
6	41451602802	Pannello di emergenza Wireless / Wireless emergency display / Wireless Notfall-Blende / Panneau d'urgence wireless / Panel emergencia wireless
7	41451801400	Cablaggio / Wiring / Verdrahtung / Cablage / Cableado
7	41451803550	Kit cablaggi messa a terra / Grounding wiring kit / Erdungskabelbaum / Kit mise à terre / Kit cableado a tierra
7	41452000500	Cavo motoriduttore / Reduction motor cable / Kabel Getriebemotor / Câble motoréducteur / Cable motorreductor
8	41451403200	Cavo USB da pannello L.500 / USB Cable from display L.500 / USB Kabel von Notfalldisplay L.500 / Câble USB de panneau L.500 / Cable USB del panel L.500
9	41451003700	Pressostato / Pressure switch / Druckschalter / Pressostat / Presostato
10	41601301851	Componente rilevamento portata aria / Air flow measure component / Bauteil für Messung der Luftmenge / Composent pour la mesuration de la quantité d'air / Componente por la medida de l'aire
11	4120631A	Tubicino siliconico - 5m / Silicon tube - 5m / Silikonrohr - 5m / Petit tuyau en silicone - 5m / Tubo silicónico - 5m
12	412007004	Clickson 110°C / Clickson 110°C / Clickson 110°C / Clickson 110°C / Clickson 110°C
13	41451303400	Trasduttore di pressione / Pressure transducer / Active-Wandler / Transducteur de pression / Transductor de pression

MUSA COMFORT AIR 14 UP! M1

Gruppo ventilazione / Ventilation group / Lüftungsgruppe / Groupe de ventilation / Grupo de ventilación

N°	Codice/Code	Descrizioni / Description / Beschreibung / Description / Descripcion
1	41451503300	Ventilatore centrifugo / Air fun / Lufgebläse / Ventilateur air / Ventilador aire
2	41801601600	Guarnizione ventilatore / Fan gasket / Dichtung des Gebläses / Joint du ventilateur / Junta ventilador
3	41401624731	Convogliatore C/Air / Conveyor C/Air / Blech C/Air / Convoyeur C/Air / Conductor C/Air
4	41200902000	Fascette Ø 64-76 mm (2 pz) / Clamps Ø 64-76 mm (2 pcs) / Rohrschellen Ø 64-76 mm (2 Stck) / Colliers Ø 64-76 mm (2 pcs) / Bandas Ø 64-76 mm (2 pzs)
5	41801601100	Tubo uscita aria silicone / Outlet air tube in silicone / Luftausgangrohr aus Silikon / Tuyau de sortie air en silicone / Tubo de salida aire en silicona
6	4011011	Flangia Ø 6 / Flange Ø 6 / Flansch Ø 6 / Bride Ø 6 / Brida Ø 6
7	41801605300	Bocchetta posteriore in silicone / Silicone rear air outlet / Luftauslass aus Silikon / Diffuseur air en silicone / Boquilla aire en silicona
8	41451600800	Ventilatore aria / Air fan / Luftgebläse / Ventilateur air / Ventilador aire
9	41801002300	Paracolpi in silicone Ø 8/5 (2pz) / Silicone bumpers Ø 8/5 (2pcs) / Schlagschutzgummi Ø 8/5 (2 Stck) / Pièces silicone antichoc Ø 8/5 (2pcs) / Anti-golpes en silicona Ø 8/5 (2pzs)

MUSA COMFORT AIR 14 UP! M1

Gruppo fumi / Smoke group / Rauchgruppe / Groupe fumées / Grupo de humos

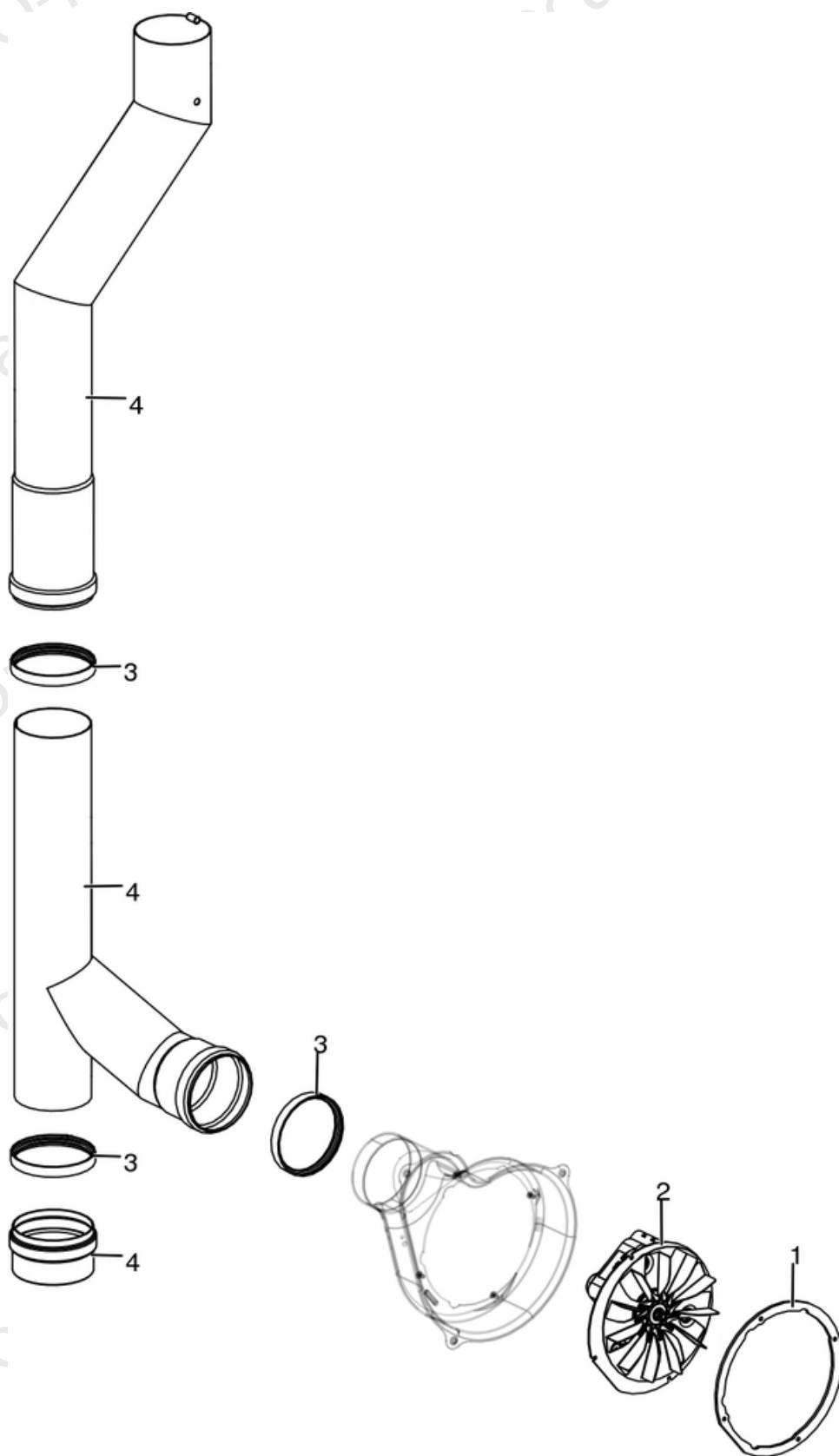

N°	Codice/Code	Descrizioni / Description / Beschreibung / Description / Descripción
1	41801600800	Guarnizione ventilatore fumi / Smoke exhaust fan gasket / Dichtung Rauchabsauggebläse / Joint Ventilateur aspiration fumées / Junta ventilador aspiración humos
2	41451503200	Ventilatore fumi stagno / Air-tight smoke fan / Luftdichtes Rauchgasgebläse / Ventilateur fumées étanche / Ventilador humos hermético
2	41451703000	Encoder per ventilatore fumi marchio EBM / Encoder for EMB smoke fan / Encoder für EBM Rauchgasgebläse / Encoder pour ventilateur des fumées marque EBM / Encoder para ventilador humos marca EBM
2	41451209300	Encoder per ventilatore fumi marchi LN2/SIT / Encoder for LN2/SIT smoke fan / Encoder für LN2/SIT Rauchgasgebläse / Encoder pour ventilateur des fumées marques LN2/SIT / Encoder para ventilador humos marcas LN2/SIT
2	41452009200	Encoder per ventilatore fumi marchio EMC / Encoder for EMC smoke fan / Encoder für EMC Rauchgasgebläse / Encoder pour ventilateur des fumées marque EMC / Encoder para ventilador humos marca EMC
3	40120969	Guarnizione silicone (5pz) / Silicone Gasket (5pc.) / Silikondichtung (5 St.) / Joint en silicone / Junta en silicona
4	41601604860	Tubo fumi Ø 80 con guarnizione / Smoke pipe Ø 80 with gasket / Rauchrohr Ø 80 mit Dichtung / Tuyau fumées Ø 80 avec joint / Tubo humos Ø 80 con junta