

PERFORMA 15 EASY CLEAN PLUS

Componenti Struttura Esterna / External structure components / Bauteile Aussenkorpus / Composants structure externe / Componentes estructura externa

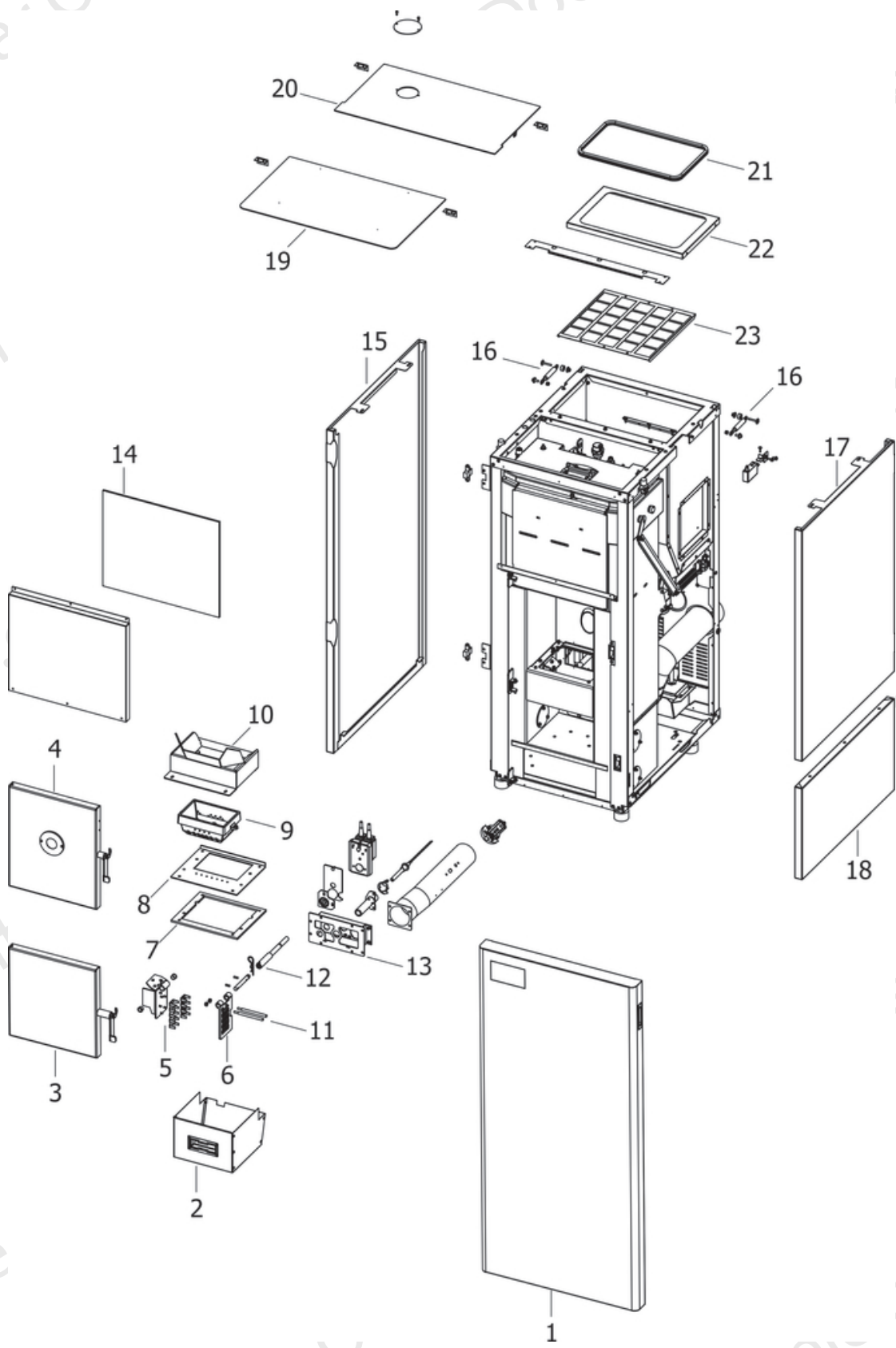

N°	Codice/Code	Descrizioni / Description / Beschreibung / Description / Descripcion
1	41411645650	Porta frontale completa / Complete front door / Komplette Fronttür / Porte frontal complète / Puerta frontal completa
1	41201501700	Cerniera Pz.2 / Hinge Pcs.2 / Scharnier Stk.2 / Charnière Pcs.2 / Bisagra Pz.2
2	41401617540	Cassetto cenere completo / Complete ash drawer / Kompletter Aschekasten / Tiroir à cendres complet / Cajón cenizas completo
2	41401631130	Vassoio raccolta cenere / Ash collection tray / Aschenlade / Plateau recuperateur des cendres / Bandeja de recogida de cenizas
3	41411647250	Porta cenere completo / Ash drawer door / Tür des Aschenkastens / Porte tiroir à cendres / Puerta cajón ceniza
4	41411647050	Porta focolare completa / Fireplace door / Feuerstelle Tür / Porte foyer / Puerta hogar
5	41411649050	Pettine pulitore completo / Complete scraper / Komplet Kratzer / Racleur complète / Raspador completo
6	41301601700V	Fondello in ghisa bruciante autopulente nero / Self-cleaning cast iron barziera bottom / Selbstreinigend Brennerkopf aus Gusseisen Boden / Fond brasero autonettoyante en fonte / Fondo brasero autolimpiador en arrabio
7	41801603500	Guarnizione focolare / Gasket / Dichtung / Joint / Junta
8	41411644930V	Base bruciante / Brazier base / Brennerkopf Basis / Base brasero / Base brasero
9	41301601600V	Bruciante in ghisa autopulente / Self-cleaning cast iron brazier / Selbstreinigend Brennerkopf aus Gusseisen / Brasero en fonte autonettoyante / Brasero en arrabio autolimpiador
10	41331601240	Deflettore focolare / Fire box deflector / Feuerstelleleitblech / Déflecteur foyer / Deflector hogar
11	41201607900	Perno griglia (pz.2) / Pivot for grille (Pcs.2) / Bolzen für Gitter (Stk.2) / Pivot pour grille (Pcs.2) / Perno para rejilla (Pz.2)
12	41201604600	Asse Belimo / Actuator shaft / Trieb Bolzen / Pivot actionneur / Perno actuador
13	41411647940V	Scatola aspirazione / Air inlet box / Lufteingangs Schachtel / Coffret entrée d'air / Caja entrada aire
14	41151600300	Isolante frontale / Front panel insulating material / Vorderes Panel Isolationsmaterial / Isolant panneau antérieur / Aislante panel frontal
15	41411646930P	Fianco intero / LH side / Li. Seitenteil / Côte G. / Lateral IZDO
16	41801101400	Pistone a gas / Gas-piston / Gas-Kolben / Piston à gaz / Pistón a gas
16	41801101400	Pistone a gas / Gas-piston / Gas-Kolben / Piston à gaz / Pistón a gas
17	41411646730P	Fianco superiore Dx / RH upper side / Obere Re. Seitenteil / Côte supérieur D. / Lateral superior DCHO
18	41411646840P	Fianco inferiore Dx / RH lower side / Unteres Re. Seitenteil / Côte inférieur D. / Lateral inferior DCHO
19	41411645850	Coperchio completo caldaia / Complete boiler cover / Komplet Deckel Kessel / Couvercle chaudière complét / Tapa caldera completa
19	41201104500	Cerniera pz.2 / Hinge Pcs.2 / Scharnier Stk.2 / Charnière Pcs.2 / Bisagra Pz.2
20	41411646150	Coperchio completo serbatoio / Complete hopper cover / Komplet Deckel Pelletbehälter / Couvercle réservoir complét / Tapa depósito completa
21	41801208002	Guarnizione - 2,5 m / Gasket - 2,5 m / Dichtung - 2,5 m / Joint - 2,5 m / Junta - 2,5 m
21	41801208000	Guarnizione - 5 m / Gasket - 5 m / Dichtung - 5 m / Joint - 5 m / Junta - 5 m
21	41801208001	Guarnizione - 50 m / Gasket - 50 m / Dichtung - 50 m / Joint - 50 m / Junta - 50 m
22	41401616630	Pannello stagno / Air-tight panel / Luftdich Platte / Panneau étanche / Panel hermético
23	41401618930	Griglia antintrusione / Hopper protection grille / Schutzgitter Pelletbehälter / Grille de protection réservoir / Rejilla de protección depósito

PERFORMA 15 EASY CLEAN PLUS

Porta fuoco / Fire door / Feuertür / Porte foyer / Puerta hogar

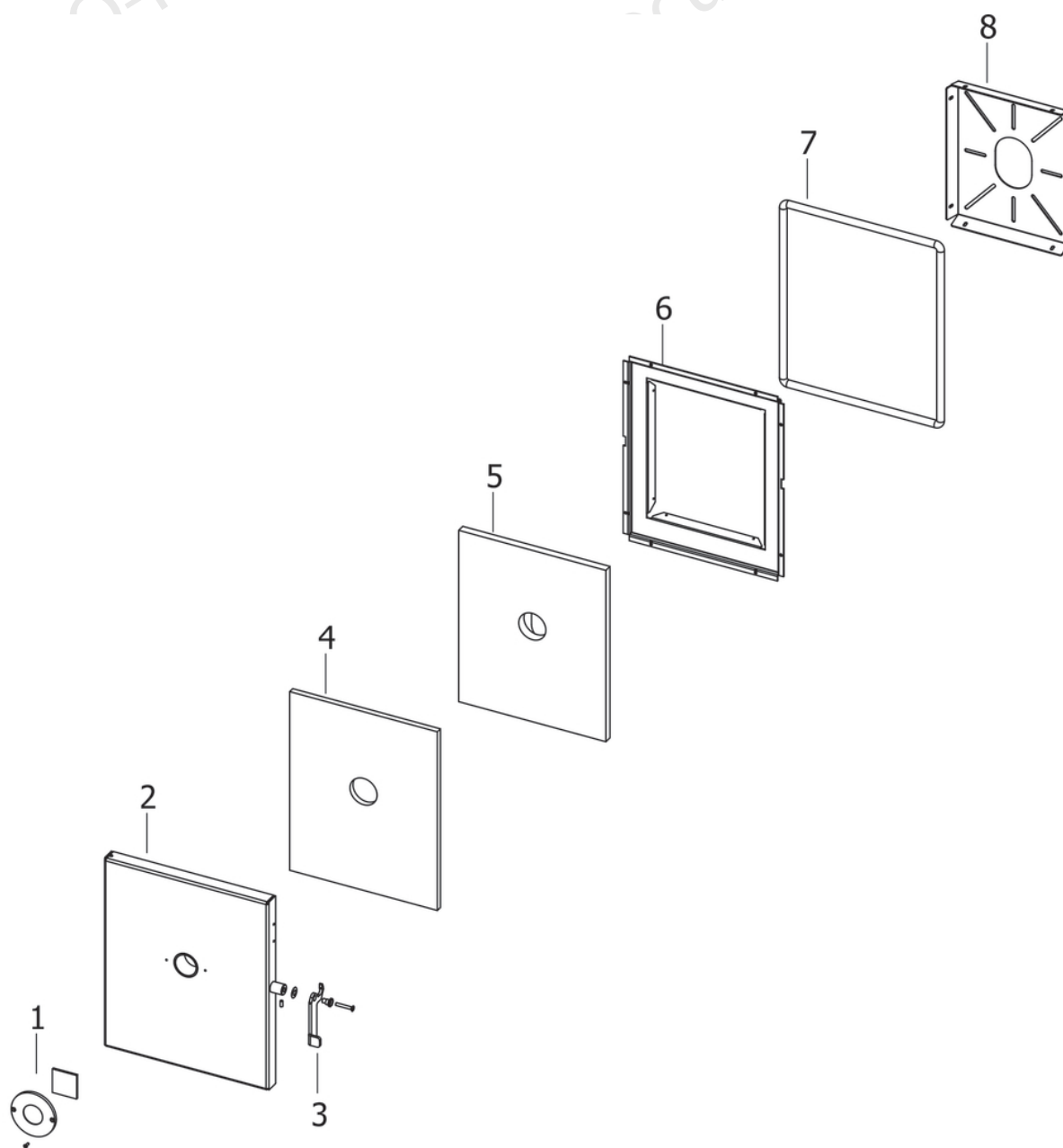

N°	Codice/Code	Descrizioni / Description / Beschreibung / Description / Descripción
1	41201302800V	Spioncino con vetro - Spioncino Ø 40 / Peephole with glass - Peephole Ø 40 / Guckloch mit Scheibe - Guckloch Ø 40 / Judas avec vitre - Judas Ø 40 / Mirilla con cristal - Mirilla Ø 40
2	41401132742V	Telaio esterno porta fuoco - Spioncino Ø 40 / External door frame - Peephole Ø 40 / Aussere Feuertürrahmen - Guckloch Ø 40 / Cadre extérieure porte - Judas Ø 40 / Armazón externo puerta - Mirilla Ø 40
3	41401133230V	Maniglia / Handle / Griff / Poignée / Tirador
4	41151101202	Isolante interno - Spioncino Ø 40 / Internal insulating material - Peephole Ø 40 / Innerer Isolationsmaterial - Guckloch Ø 40 / Isolant intérieur - Judas Ø 40 / Aislante interno - Mirilla Ø 40
5	41151600600	Isolante porta focolare / Fireplace door insulating material / Feuerstelle Tür Isolationsmaterial / Isolant porte foyer / Aislante puerta hogar
6	41411647130V	Pannello interno / Internal panel / Inner Paneel / Panneau intérieur / Panel interior
7	412007003A	Cordino fibroceramico Ø 14 mm (5 mt.) / Ceramic fibre cord Ø 14 mm (5 m.) / Keramikfaserschnur Ø 14 mm (5 m) / Cordon en fibre céramique Ø 14 mm (5 m) / Junta a cuerda de fibra cerámica Ø 14 mm (5 m)
8	41401619130	Scudo porta completo / Fireplace door cover / Feuerstelle Tür Abdeckung / Coverture porte foyer / Tapa puerta hogar

8	41402074930	Scudo porta completo INOX / Fireplace door cover INOX / Feuerstelle Tür Abdeckung INOX / Coverture porte foyer INOX / Tapa puerta hogar INOX
---	-------------	--

PERFORMA 15 EASY CLEAN PLUS

Componenti interni meccanici ed elettronici / Electronic and mechanic internal parts / Interne mechanische und elektronische Bauteile / Composants internes mécaniques et électroniques / Componentes internos electrónicos y mecánicos

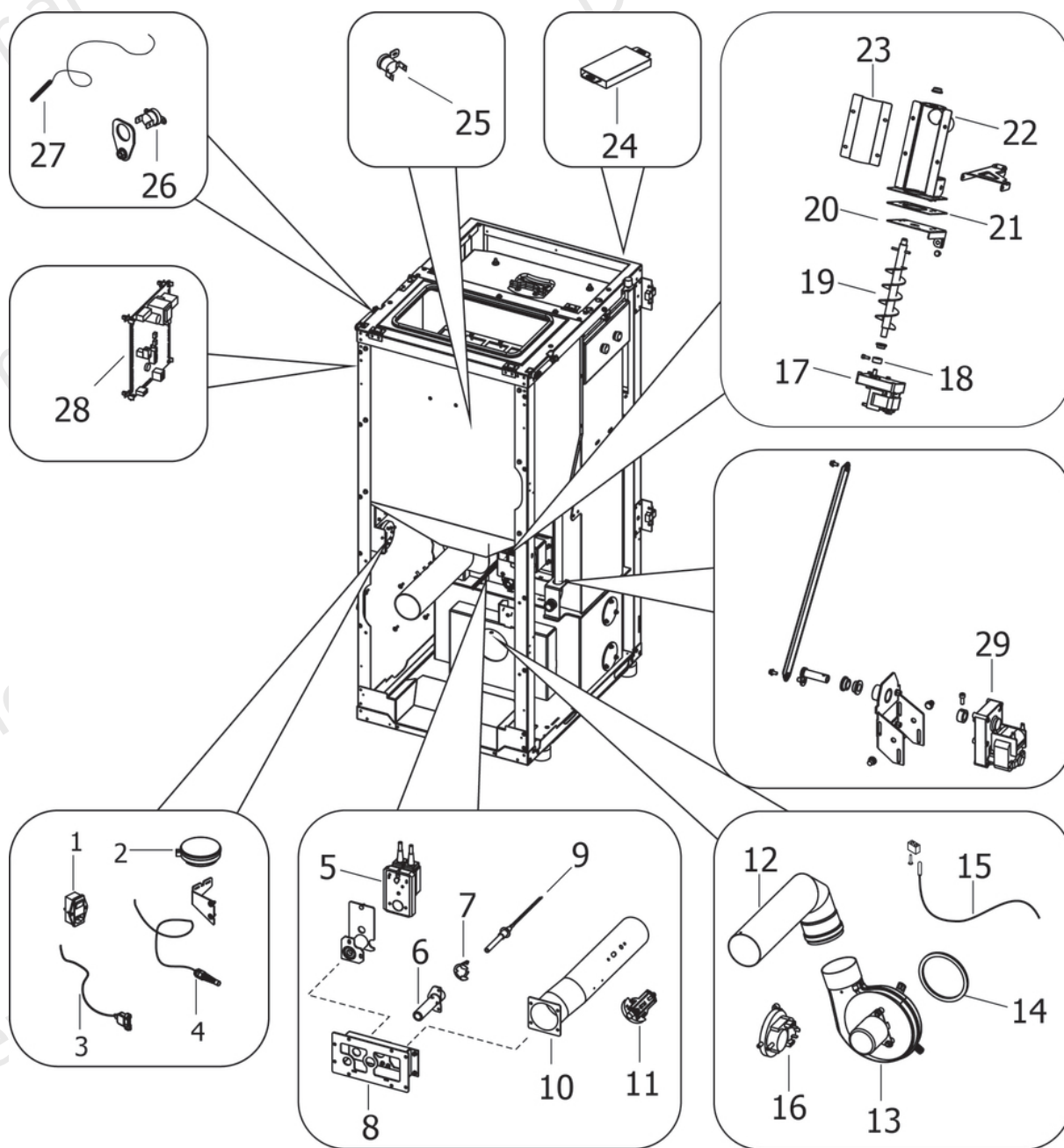

N°	Codice/Code	Descrizioni / Description / Beschreibung / Description / Description
1	4160193	Pulsante accensione / On/Off button / Zündungstaste / Touche d'allumage / Botón encendido
2	41451303400	Trasduttore di pressione / Pressure transducer / Active-Wandler / Transducteur de pression / Transductor de pression
3	41451403200	Cavo USB da pannello L.500 / USB Cable from display L.500 / USB Kabel von Notfalldisplay L.500 / Câble USB de panneau L.500 / Cable USB del panel L.500
4	4160386	Sonda temperatura ambiente/acqua / Room/Water temperature sensor / Raum- Wassertemperaturfühler / Sonde température ambiance/eau / Sonda temperatura ambiente/agua
5	41451203300	Attuatore / Actuator / Trieb / Actionneur / Actuador
6	41411648240V	Condotto candeletta / Sparkplug duct / Zündkerzenkanal / Conduit bougie / Conducto bujía
6	4141178494000	Condotto candeletta - Potenziamento accensione / Sparkplug duct - Ignition enhancement / Zündkerzenkanal -

		Zündungsverbesserung / Conduit bougie - Amélioration allumage / Conducto bujía -Mejora el encendido
7	41401620030	Anello arresto candeletta / Sparkplug stop / Zündkerzestopper / Butée bougie / Tope bujía
8	41411647940V	Scatola aspirazione / Air inlet box / Lufteingangs Schachtel / Coffret entrée d'air / Caja entrada aire
9	41451308101	Candeletta 315 Watt / Sparkplug 315 Watt / Zündkerze 315 Watt / Bougie 315 Watt / Bujía 315 Watt
9	41452009900	Candeletta 300 Watt / Sparkplug 300 Watt / Zündkerze 300 Watt / Bougie 300 Watt / Bujía 300 Watt
10	41601603500V	Tubo aspirazione nero / Black air inlet pipe / Schwarz Lufteingangsrohr / Tuyau entrée d'air noir / Tubo entrada aire negro
11	41601306151	Componente rilevamento portata aria / Air flow measure component / Bauteil für Messung der Luftmenge / Composant pour la mesuration de la quantité d'air / Componente por la medida de l'aire
12	41601103960	Tubo uscita fumi / Smoke outlet pipe / Rohr Rauchabzug / Tuyau sortie fumées / Tubo salida humos
13	41451201750	Ventilatore fumi / Smoke exhaust fan / Rauchabsauggebläse / Ventilateur aspiration fumées / Ventilador aspiración de humos
14	41801100100	Guarnizione adesiva voluta fumi / Adhesive gasket smoke volute / Haftenddichtung Rauchvolute / Joint adhesive volute fumées / Junta adhesiva voluta humos
15	41451601700	Sonda fumi / Smoke sensor / Rauchgasfühler / Sonde fumées / Sonda humos
16	4160482	Pressostato 0,4 mbar / Pressure gauge 0,4 mbar / Druckschalter 0,4 mbar / Pressostat 0,4 mbar / Presostato 0,4 mbar
17	41451204900	Motoriduttore 3,3 RPM / Reduction motor 3,3 RPM / Getriebemotor 3,3 RPM / Motorréducteur 3,3 RPM / Motorreductor 3,3 RPM
18	4120398	Connettore motoriduttore-coclea / Reduction motor-feed screw connector / Verbindung Getriebemotor-Schnecke / Connecteur motorréducteur-vis sans fin / Conector motorreductor-cóclea
19	43640424	Coclea di caricamento pellet / Pellet feed screw / Pellet Förderschnecke / Vis sans fin pour chargement du pellet / Cóclea de carga pellet
20	41201216500	Boccola (2 pz) / Bushing (2 pcs) / Buchse (2 Stk) / Douille (2 pcs) / Abrazadera (2 pzs)
20	41411688850	Base della coclea / Feed screw base / Untergestell der Förderschnecke / Base de la vis sans fin / Base de la cóclea
21	4120615	Guarnizione base della coclea / Feed screw base gasket / Dichtung Untergestell der Förderschnecke / Joint pour la base de la vis sans fin / Junta base de la cóclea
22	41411650640V	Condotto alimentazione / Auger conduit / Rohrleitung der Förderschnecke / Conduit de la vis sans fin / Conducto de la cóclea
23	41401227530	Coperchio coclea / Feed screw cover / Deckel der Rohrleitung / Couvercle de la vis sans fin / Tapa de la cóclea
24	41451303600	Cavo connessione pannello / Control panel connection cable / Bedienblende Verbindungskabel / Cable de connection au tableau / Cable de conexión panel de comando
24	41451303706	Pannello comandi Hottoh 129 / Control panel Hottoh 129 / Bedienblende Hottoh 129 / Tableau de commande Hottoh 129 / Panel de mandos Hottoh 129
25	412007004	Clickson 110°C / Clickson 110°C / Clickson 110°C / Clickson 110°C / Clickson 110°C
26	41451601900	Termostato a contatto 85°C / Thermostat 85°C / Thermostat 85°C / Thermostat 85°C / Termóstato 85°C
27	4012062	Sonda NTC a filo per acqua / Water temperature sensor / Wassertemperaturfühler / Sonde température eau / Sonda temperatura agua
28	41451303805	Scheda madre Hottoh 149 / Hottoh motherboard 149 / Hauptplatine Hottoh 149 / Carte mère Hottoh 149 / Tarjeta madre Hottoh 149
28	41451303807	Scheda madre Hottoh 149 / Hottoh motherboard 149 / Hauptplatine Hottoh 149 / Carte mère Hottoh 149 / Tarjeta madre Hottoh 149
28	41451308200	Schedino aggiuntivo Hottoh / Hottoh additional motherboard / Hottoh zusätzliche Platine / Carte mère supplémentaire Hottoh / Tarjetita madre adicional Hottoh
28	41451601800	Cablaggio completo / Complete wiring / Komplette Verkabelung / Câblage complet / Cableado completo
29	41450901600	Motoriduttore 3,3 rpm Merkle Korff / Reduction motor 3,3 rpm Merkle Korff / Getriebemotor 3,3 RPM MERKLE KORFF / Motorréducteur 3,3 RPM MERKLE KORFF / Motorreductor 3,3 rpm Merkle Korff

PERFORMA 15 EASY CLEAN PLUS

Componenti interni idraulici **SENZA** kit acqua sanitaria / Internal plumbing components **WITHOUT** domestic water kit / Interne hydraulische Bauteile **OHNE** Brauchwassersatz / Composants hydrauliques internes **SANS** kit eau sanitaire / Componentes internos hidráulicos **SIN** kit de agua sanitaria

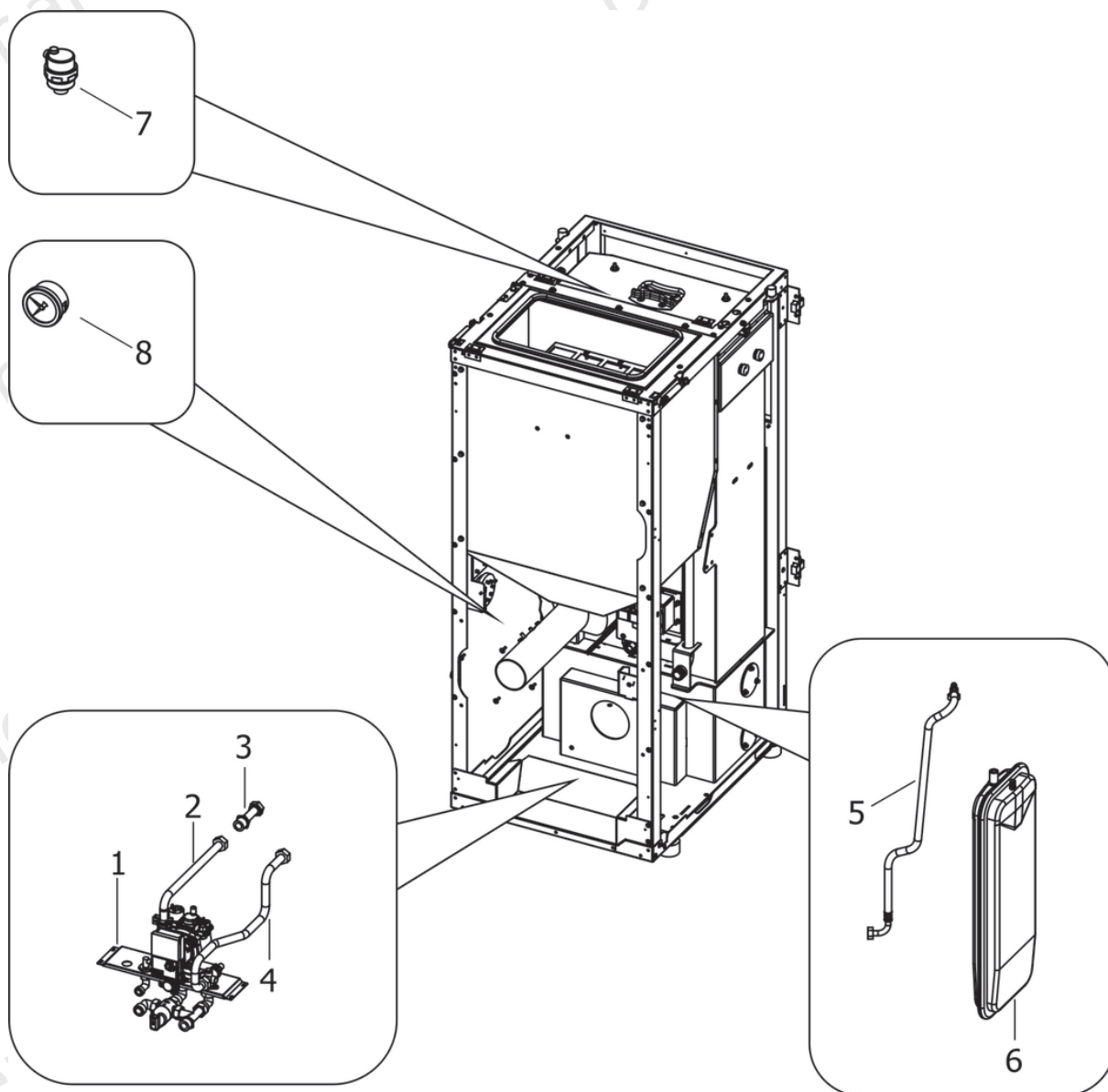

N°	Codice/Code	Descrizioni / Description / Beschreibung / Description / Descripción
1	41501602150	GRUPPO IDRAULICO - SOLO RISCALDAMEN TO / HYDRAULIC UNIT - HEATING ONLY / HYDRAULIKEINHEIT - NUR HEIZUNG / UNITÉ HYDRAULIQUE - SEUL CHAUFFAGE / UNIDAD HIDRÁULICA - SOLO CALENTAMIE NTO
1	41451108000	Pressostato di minima H2O / Pressur switch H2O / Druckwächter H2O / Pressostat H2O / Presostato H2O
1	41501103300	Valvola di sicurezza 3 Bar / Maximum pressure valve 3 Bar / Sicherheitsventil 3 Bar / Soupape de pression maximale 3 Bar / Válvula máxima presión 3 Bar
1	41501305100	Rubinetto a spillo / Needle valve / Nadelventil / Soupape à pointeau / Válvula de aguja
1	41502002100	Circolatore Wilo Para 7 IPWM / Water circulation pump Wilo Para 7 IPWM / Umwälzpumpe Wilo Para 7 IPWM / Pompe de circulation Wilo Para 7 IPWM / Bomba de circulación agua Wilo Para 7 IPWM
1	41501700100	Valvola anticondensa / Back end protection / Thermostatisches Ventil / Vanne Anti Condensatio / Valvula Anti Condensación
1	41501900100	Cartuccia per valvola anticondensa 41501701200. / NEW CARTRIDGE for back-end protection / NEUE PATRONE für Anti-Kontensationsventil / NOUVELLE CARTOUCHE pour valve anticondensation / Nuevo cartucho para valvula anticondensa

1	41501701200	Valvola anticondensa / Back end protection / Thermostatisches Ventil / Vanne Anti Condensatio / Valvula Anti Condensación
1	41501701300	Tubo mandata valvola anticondensa / Delivery hose anticondensation valve / Zuführschlauch Anti-Kondensationsventil / Tuyau de déchargement vanne anticondensation / Tubos de envío válvula anti condensación
1	41501701400	Tubo ritorno valvola anticondensa / Back pipe anticondensation valve / Zurückrohr Anti-Kondensationsventil / Tuyau de retour vanne anticondensation / Tubos de retorno válvula anti condensación
2	41501602300	Tubo mandata kit idraulico / Heating water delivery tube / HeizungsVorlaufrohr / Tuyau de refoulement eau chauffage / Tubo de envío de agua calentamiento
3	41501602000	Raccordo mandata impianto / Delivery tube connection / Vorlaufrohr Verbindung / Raccord tuyau refoulement / Raccor tubo de envío
4	41501602400	Tubo ritorno kit idraulico / Pump connection tube / Verbindungsrohr zur Pumpe / Tuyau de connection à la pompe / Tubo de conexión a la bomba
5	41501100800	Tubo di mandata acqua da caldaia / Boiler water delivery tube / Vorlaufrohr Wasser vom Kessel / Tuyau de refoulement eau de la chaudière / Tubo de envío de agua de la caldera
6	4120775	Vaso espansione (6 l) / Expansion vessel (6 l) / Expansionsgefäß (6 l) / Vase d'expansion (6 l) / Vaso de expansión (6 l)
7	4120779	Valvola di sfiato / Vent valve / Entlüftungsventil / Soupape de dégagement / Válvula respiradero
8	41501100901	Manometro / Manometer / Manometer / Manomètre / Manómetro

PERFORMA 15 EASY CLEAN PLUS

Kit Ash Trolley / Kit Ash Trolley / Kit Ash Trolley / Kit Ash Trolley / Kit Ash Trolley

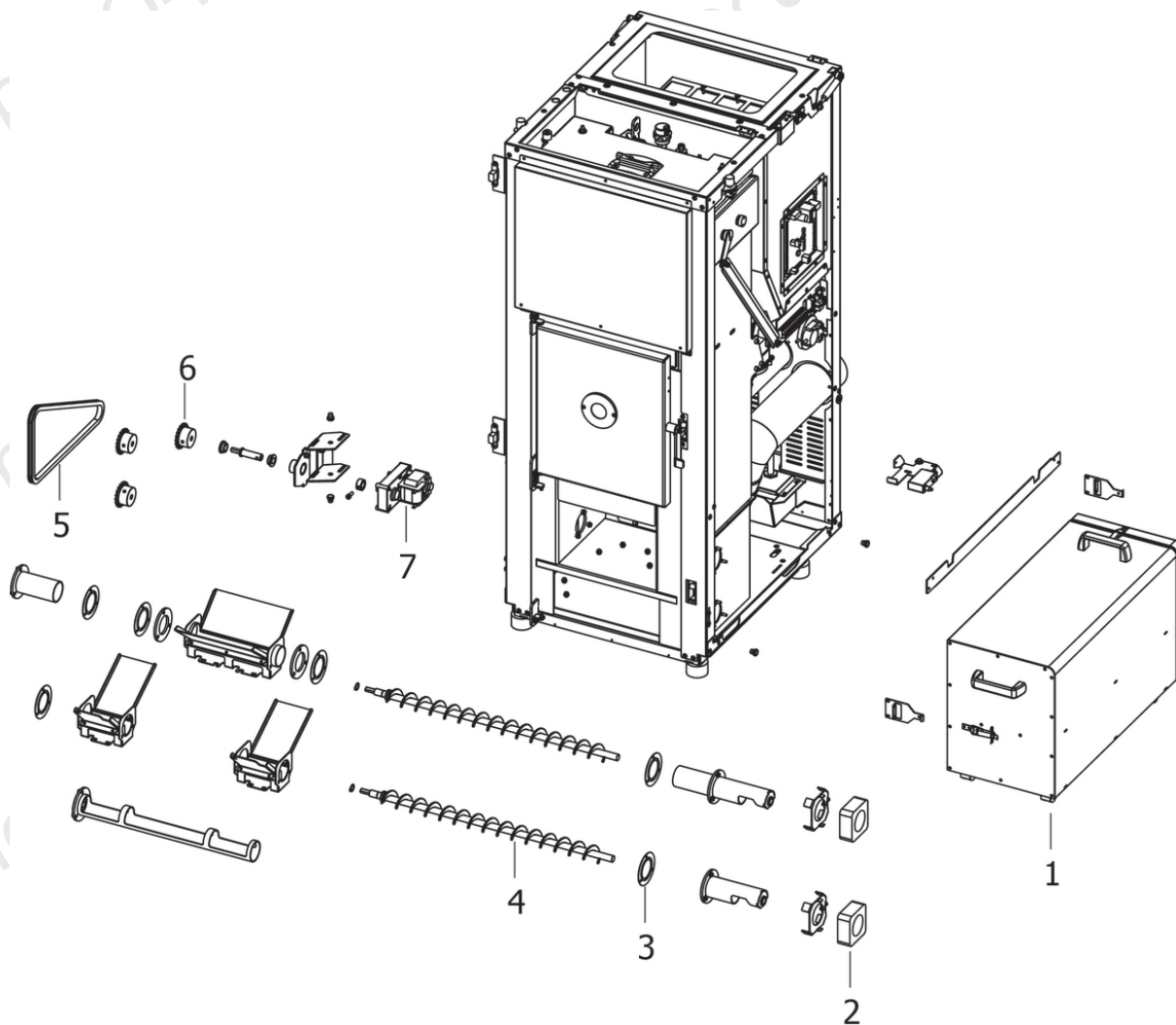

N°	Codice/Code	Descrizioni / Description / Beschreibung / Description / Descripción
1	41401703430	Scivolo raccolta cenere / Ash ramp / Aschenrutsche / Glissière cendre / Tobogán ceniza
1	41401710130	Scivolo raccolta cenere anteriore / Front ash ramp / Frontaschenrutsche / Glissière cendre devant / Tobogán ceniza frontal
1	41801401100	Ruota ø30 trolley (pz.4) / Wheel ø30 trolley (Pcs.4) / Räder ø30 trolley (Stk.4) / Roue ø30 trolley (Pcs.4) / Rueda ø30 trolley (Pz.4)
1	437016149	Trolley finito / Trolley / Trolley / Trolley / Trolley
2	41801606500	Guarnizione / Gasket / Dichtung / Joint / Junta
3	41801603700	Guarnizione tappo struttura / Gasket structure plugs / Dichtung Strukturklappe / Joint clapets de la structure / Junta tapónes estructura
4	41201605840	Coclea estrazione cenere / Ash screw / Aschenschnecke / Vis-sans-fin cendre / Cóclea ceniza
5	41201605600	Catena a rulli / Roller chain / Rollenkette / Chaîne à rouleaux / Cadena de rodillos
5	41401801530	Staffa aggiuntiva motoriduttore / Gearmotor additional bracket / Schneckenmotor zusätzliches Haltebügel / Étrier additionnel motoreducteur / Abrazadera adicional motoreductor
6	41201605720	Pignone catene / Chain sprocket / Kettenritzel / Pignon de chaîne / Pinon de cadena
6	41201606300	Albero pignone / Pinion shaft / Arbre de pignon / Ritzelwelle / Eje del piñón
6	41201216500	Boccola (2 pz) / Bushing (2 pcs) / Buchse (2 Stk) / Douille (2 pcs) / Abrazadera (2 pzs)
7	41450901600	Motoriduttore 3,3 rpm Merkle Korff / Reduction motor 3,3 rpm Merkle Korff / Getriebemotor 3,3 RPM MERKLE KORFF / Motoréducteur 3,3 RPM MERKLE KORFF / Motorreductor 3,3 rpm Merkle Korff
7	41401801530	Staffa aggiuntiva motoriduttore / Gearmotor additional bracket / Schneckenmotor zusätzliches Haltebügel / Étrier

		additional motoreducteur / Abrazadera adicional motoreductor
7	41411649740V	Supporto motoriduttore / Reduction motor support / Schneckenmotor Gestell / Support motoréducteur / Soporte motoreductor

PERFORMA 15 EASY CLEAN PLUS

Gruppo scambiatore / Exchanger group / Austausch Baugruppe / Groupe échangeur / Grupo intercambiador

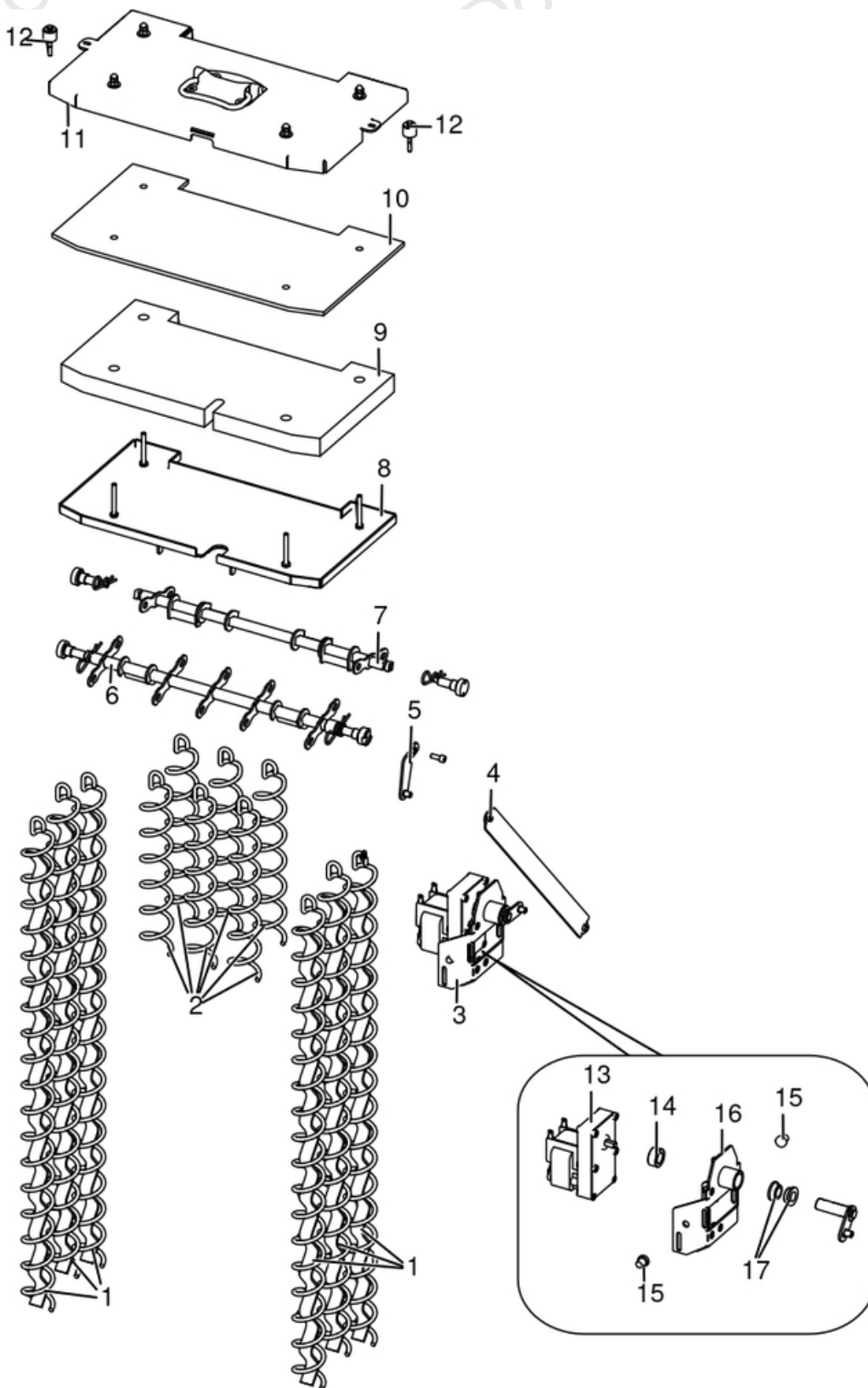

N°	Codice/Code	Descrizioni / Description / Beschreibung / Description / Descripcion
1	41331602240	Turbolatore lungo / Turbulator / Propeller des Schabers / Turbulateur / Rascador
2	41201302400	Eliche raschiatore Inox (1 pz.) / Inox Turbulator props (1 pc.) / Propeller des Schabers Inox (1 Teil) / Hélices turbulateur Inox (1 pz.) / Hélice rascador Inox (1 pz.)
3	41411649651	Motore turbolatore / Turbulator engine / Turbulator motor / Moteur turbulateur / Motor turbulador
4	41401619441	Asta turbolatore completo / Complete turbulator rod / Komplette Turbulator Stange / Tige de turbulateur complète / Varilla de turbulador completa
5	41411713440V	Braccio turbolatore / Turbulator Arm / Turbulatorarm / Bras de turbulateur / Brazo del turbulador
6	41401700150	Asse turbolatori anteriori / Front turbulator shaft / Vordere Turbulator Stange / Tige turbolateurs antérieurs / Asta rascadores anteriores
7	41331602040	Asse turbolatori posteriori / Rear turbulator shaft / Hintere Turbulator Stange / Tige turbolateurs postérieurs / Asta rascadores posteriores
8	41331602640	Involucro inferiore completo / Lower complete casing / Untere komplett Hülle / Enveloppe complète inférieure / Envoltura inferior completa
9	41151601200	Isolante coperchio / Cover insulating material / Deckel Isolationsmaterial / Isolant couvercle / Aislante tapa
10	41151601100	Isolante coperchio / Cover insulating material / Deckel Isolationsmaterial / Isolant couvercle / Aislante tapa
11	41411650240V	Coperchio testata / Cover / Deckel / Couvercle / Tapa
12	41801499550	Kit scarico sovrappressione camera di combustione (pz.2) / Pressure relief kit (Pcs.2) / Bausatz überdruckablauf brennkammer (Stck.2) / Kit decompression chambre combustion (Pcs.2) / Kit descompresion camara combustion (Pcs.2)
13	41450901600	Motoriduttore 3,3 rpm Merkle Korff / Reduction motor 3,3 rpm Merkle Korff / Getriebemotor 3,3 RPM MERKLE KORFF / Motoréducteur 3,3 RPM MERKLE KORFF / Motorreductor 3,3 rpm Merkle Korff
14	4120398	Connettore motoriduttore-coclea / Reduction motor-feed screw connector / Verbindung Getriebemotor-Schnecke / Connecteur motoréducteur-vis sans fin / Conector motorreductor-cóclea
15	4120180	Gommini paracolpi (4 pz) / Rubber bumpers (4 pcs.) / Schlagschutzgummi (4 Stck) / Pièces caoutchouc antichoc (4 pcs) / Cauchitos anti-golpes (4 pz)
16	41411649740V	Supporto motoriduttore / Reduction motor support / Schneckenmotor Gestell / Support motoréducteur / Soporte motoreductor
17	41201216500	Boccola (2 pz) / Bushing (2 pcs) / Buchse (2 Stk) / Douille (2 pcs) / Abrazadera (2 pzs)