

SUITE HYDROMATIC 24 KW

Componenti Struttura Esterna / External structure components / Bauteile Aussenkorpus / Composants structure externe / Componentes estructura externa

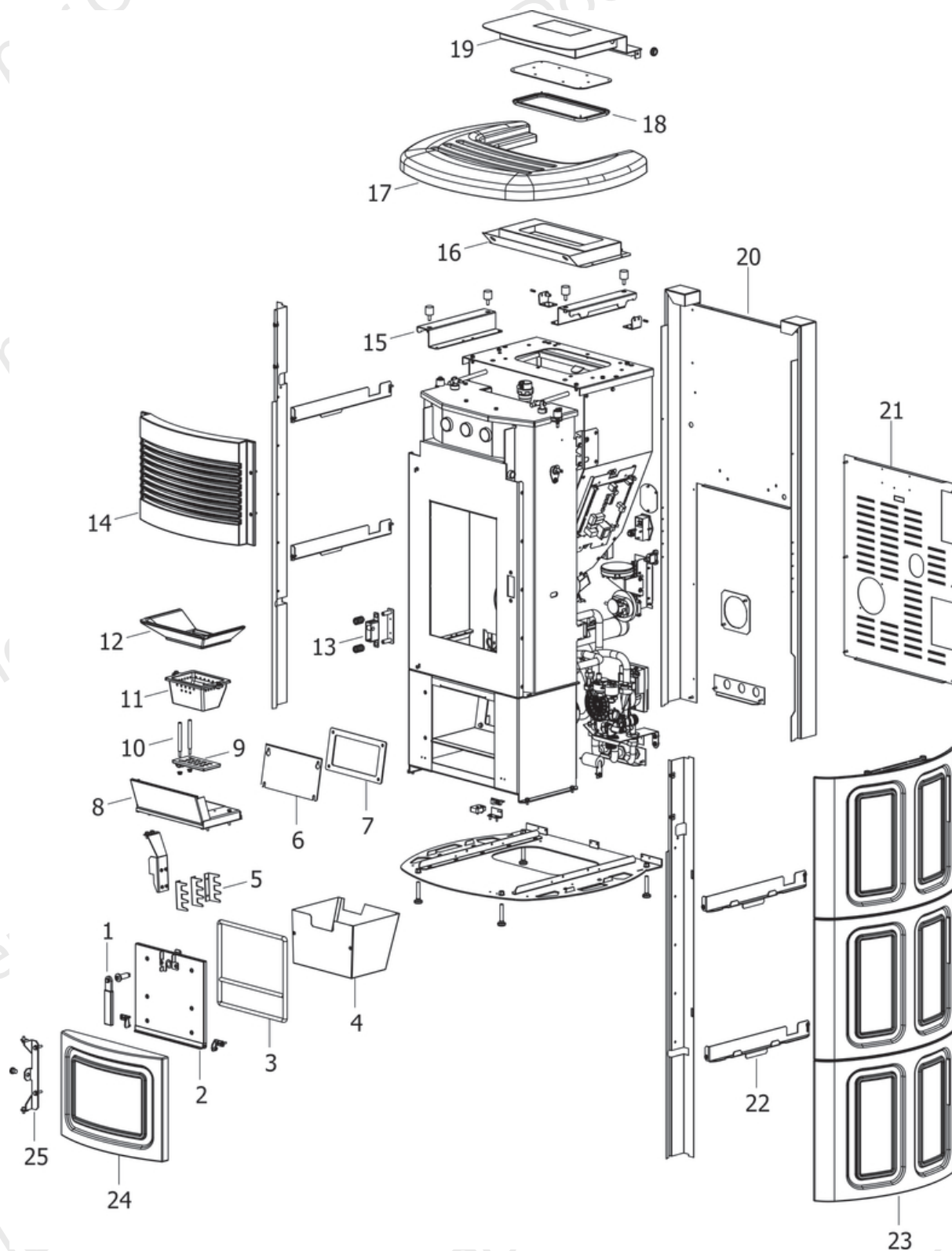

N°	Codice/Code	Descrizioni / Description / Beschreibung / Description / Description
----	-------------	--

1	41411621600	Maniglia con impugnatura porta cenere / Handle / Griff / Poignée / Tirador
2	437016077	Porta cassetto cenere / Ash drawer door / Tür des Aschenkastens / Porte tiroir à cendres / Puerta cajón ceniza
3	4120104A	Cordino fibroceramico Ø 12 mm (5 mt.) / Ceramic fibre cord Ø 12 mm (5 m.) / Keramikfaserschnur Ø 12 mm (5 m) / Cordon en fibre céramique Ø 12 mm (5 m) / Junta a cuerda de fibra cerámica Ø 12 mm (5 m)
3	4120104B	Cordino fibroceramico Ø 12 mm (50 mt.) / Ceramic fibre cord Ø 12 mm (50 m.) / Keramikfaserschnur Ø 12 mm (50 m) / Cordon en fibre céramique Ø 12 mm (50 m) / Junta a cuerda de fibra cerámica Ø 12 mm (52 m)
3	41201041	Kit sostituzione cordino (cordino+silicone) Ø 12 mm / Cord replacement kit (cord + silicone) Ø 12 mm / Schnuraustauschsetz (Schnur+Silikon) Ø 12 mm / Kit remplacement cordon (cordon + silicone) Ø 12 mm / Kit sustitución junta a cuerda (junta a cuerda+silicón) Ø 12 mm
4	437016041	Cassetto cenere / Ash drawer / Aschenkasten / Tiroir à cendres / Cajón ceniza
5	41401605730	Spuntoni fondo braciere / Bottom fireplace scraper / Brenntopf Kratzer / Racleur fond foyer / Raspador fondo hogar
6	41401605530	Tappo camera fumi zincato / Smoke compartment galvanized plug / Verzinktes Rauchabzugklappe / Join zingué compartiment fumées / Tapón galvanizado compartimento humos
7	41801601300	Guarnizione tappo camera fumi / Smoke compartment plug gasket / Dichtung Rauchabzugklappe / Joint clapet compartiment fumées / Junta tapón compartimento humos
8	41411609440V	Convogliatore aria vetro / Air duct / Luftförderer / Convoyeur d'air / Canalizador aire
9	41301601000V	Fondo braciere ghisa autopulente / Self-cleaning cast iron grate bottom / Selbstreinigend Brenntopf aus Gusseisen / Fond brasero en fonte autonettoyant / Fondo brasero en arrabio autolimpiador
10	41201601400	Asta pulitrice fondo braciere autopulente (pz.2) / Self-cleaning cast iron bottom grate rod (Pcs.2) / Selbstreinigend Brenntopf aus Gusseisen Bolzen Stange (Stk.2) / Tige fond brasero en fonte autonettoyant (Pcs.2) / Asta fondo brasero en arrabio autolimpiador (Pz.2)
11	41301601100V	Braciere ghisa autopulente / Self-cleaning cast iron grate / Selbstreinigend Brenntopf aus Gusseisen / Brasero en fonte autonettoyant / Brasero en arrabio autolimpiador
12	41301601200V	Scivolo braciere ghisa autopulente / Self-cleaning grate amp / Selbstreinigend Brenntopf Rutsche / Glissière brasero autonettoyant / Tobogán brasero autolimpiador
13	41411599950	Kit serratura ammortizzato / Pressur relief kit / Bausatz Überdruckablauf Brennkammer / Kit deocompression chambre comcustion / Kit decompression camara combustion
14	41301503200V	Griglia aria superiore in ghisa / Upper cast iron air grille / Obere Luftgitter aus Guß / Grille air supérieur en fonte / Rejilla aire superior de arrabio
15	41401607931	Fermo supporto fianco ceramica / Side ceramic support stop / Seiten Keramikträger Stopper / Stop support côte en céramique / Tope soporte lateral en cerámica
16	41411611530V	Tamponazione serbatoio nera / Pellet hopper filling / Pelletbehälter Stopfung / Tampon réservoir / Taponado depósito
17	41251404660	Top in ceramica Salt and Pepper / Salt and Pepper ceramic top / Keramiktop Salt and Pepper / Dessus en céramique Salt and Pepper / Top en cerámica Salt and Pepper
17	41251404760	Top in ceramica Old Amber / Old Amber ceramic top / Keramiktop Old Amber / Dessus en céramique Old Amber / Top en cerámica Old Amber
17	41251403360	Top in ceramica Bordeaux / Bordeaux ceramic top / Keramiktop Bordeaux / Dessus en céramique Bordeaux / Top en cerámica Bordeaux
17	41201105600	Antivibranti (10 pz) / anti-vibration mountings (10 pcs) / Schwingungsdämpfer (10 Stck) / Éléments antivibratoires (10 pcs) / Anti-vibraciones (10 pz)
18	41801601400	Guarnizione coperchio serbatoio / Pellet hopper cover gasket / Deckel Pelletbehälter Dichtung / Joint couvercle réservoir pellet / Junta tapa depósito pellet
19	41411611640P	Coperchio serbatoio completo nero / Complete black hopper cover / Schwarz komplet Deckel Pelletbehälter / Couvercle réservoir complét noir / Tapa depósito completa negra
20	41411611230P	Schienale nero / Black back panel / Schwarz hintere Paneel / Panneau posterieur noir / Panel posterior negro
20	4141161124100	Schienale nero / Black back panel / Schwarz hintere Paneel / Panneau posterieur noir / Panel posterior negro
21	41411610131P	Pannello posteriore nero / Black rear panel / Hintere schwarze Rückwand / Panneau postérieur noir / Panel trasero negro
21	41411610132P	Pannello posteriore nero / Black rear panel / Hintere schwarze Rückwand / Panneau postérieur noir / Panel trasero negro
21	4141161013300	Pannello posteriore nero / Black rear panel / Hintere schwarze Rückwand / Panneau postérieur noir / Panel trasero negro
22	41401607731	Staffa destra supporto ceramica / Ceramic right bracket / Rechte Keramikbügel / Étrier droit céramique / Abrazadera derecha cerámica
22	41401607831	Staffa sinistra supporto ceramica / Ceramic left bracket / Linke Keramikbügel / Étrier gauche céramique / Abrazadera izquierda cerámica
23	41251405050	Ceramica laterale Salt and Pepper / Salt and Pepper lateral ceramic / Seitliche Keramik Salt and Pepper / Céramique latérale Salt and Pepper / Cerámica laterale Salt and Pepper
23	41251405150	Ceramica laterale Old Amber / Old Amber lateral ceramic / Seitliche Keramik Old Amber / Céramique latérale Old Amber / Cerámica laterale Old Amber

23	41251403850	Ceramica laterale Bordeaux / Bordeaux lateral ceramic / Seitliche Keramik Bordeaux / Céramique latérale Bordeaux / Cerámica laterale Bordeaux
24	41201305100	Chiusura a spinta / Push-pull pressure closing / Druckschließung / Fermeture par pression / Cierre a presión
24	41251602750	Ceramica inferiore completa Sale&Pepe / Complete salt and pepper lower ceramic / Komplette untere Keramik Salz und Pfeffer / Carreaux inférieurs en céramique poivre et sel complète / Cerámica inferior sal y pimenta completa
24	41251602850	Ceramica inferiore completa Old Amber / Complete lower ceramic OLD AMBER / Komplette untere Keramik OLD AMBER / Carreaux inférieurs en céramique OLD AMBER complète / Cerámica inferior OLD AMBER completa
24	41251602950	Ceramica inferiore completa Bordeaux / Complete lower ceramic BORDEAUX / Komplette untere Keramik BORDEAUX / Carreaux inférieurs en céramique BORDEAUX complète / Cerámica inferior BORDEAUX completa
25	41411612030V	Supporto pannello inferiore nero / Black lower panel support / Untere Paneel Gestell / Support panneau inférieur noir / Soporte panel inferior negro

SUITE HYDROMATIC 24 KW

Porta fuoco / Fire door / Feuertür / Porte foyer / Puerta hogar

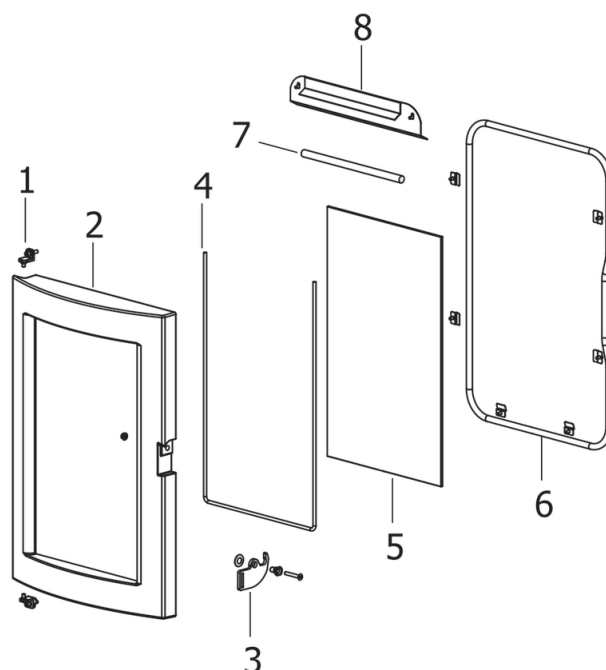

N°	Codice/Code	Descrizioni / Description / Beschreibung / Description / Description
1	412008063	Cerniere porta fuoco (2 pz) / Fire door hinge (2pcs) / Scharnier Feuertür (2 Stck) / Charnière porte foyer (2 pcs) / bisagra puerta del hogar (2 pz)
2	41301400100V	Telaio porta fuoco in ghisa / Cast iron fire door frame / Feuertürrahment aus Guß / Cadre porte foyer en fonte / Armazón puerta hogar de arrabio
2	41301400101V	Telaio porta fuoco in ghisa / Cast iron fire door frame / Feuertürrahment aus Guß / Cadre porte foyer en fonte / Armazón puerta hogar de arrabio
2	437016034	Porta focolare / Fireplace door / Feuerstelle Tür / Porte foyer / Puerta hogar
3	41401424160	Maniglia completa / Complete handle / Kompletter Griff / Poignée complète / Tirador completo
4	41801603300A	Guarnizione Ø5 5mt / Gasket Ø5 5mt / Dichtung Ø5 5mt / Joint Ø5 5mt / Junta Ø5 5mt
4	41801603300B	Guarnizione Ø5 50mt / Gasket Ø5 50mt / Dichtung Ø5 50mt / Joint Ø5 50mt / Junta Ø5 50mt
4	41801603300C	Guarnizione Ø5 5mt + silicone / Gasket Ø5 5mt + silic / Dichtung Ø5 5mt + Silikon / Joint Ø5 5mt + silic / Junta Ø5 5mt
5	41701400260	Vetroceramico 430x268x4 mm con guarnizione / Glass 430x268x4 mm with gasket / Glasskeramikscheibe 430x268x4 mm mit Dichtung / Vitrocéramique 430x268x4 mm avec joint / Cristal cerámico 430x268x4 mm con junta
5	41701400261	Vetroceramico 435x268x4 mm con guarnizione / Glass 435x268x4 mm with gasket / Glasskeramikscheibe 435x268x4 mm mit Dichtung / Vitrocéramique 435x268x4 mm avec joint / Cristal cerámico 435x268x4 mm con junta
6	4120103A	Cordino fibroceramico Ø 10 mm (5 mt.) / Ceramic fibre cord Ø 10 mm (5 m) / Keramikfaserschnur Ø 10 mm (5 m) / Cordon en fibre céramique Ø 10 mm (5 m) / Junta a cuerda de fibra cerámica Ø 10 mm (5 m)
6	4120103B	Cordino fibroceramico Ø 10 mm (50 mt.) / Ceramic fibre cord Ø 10 mm (50 m) / Keramikfaserschnur Ø 10 mm (50 m) / Cordon en fibre céramique Ø 10 mm (50 m) / Junta a cuerda de fibra cerámica Ø 10 mm (50 m)
6	41201031	Kit sostituzione cordino (cordino+silicone) Ø 10 mm / Cord replacement kit (cord + silicon) Ø 10 mm / Schnuraustauschset (Schnur+Silikon) Ø 10 mm / Kit remplacement cordon (cordon + silicone) Ø 10 mm / Kit sustitución junta a cuerda (junta a cuerda+silicón) Ø 10 mm
7	41401611030	Deflettore aria vetro / Door deflector / Leitblech der Tür / Déflecteur de la porte / Deflector de la puerta
8	41411609730V	Profilo tamponazione porta nero / Door filler frame / Türstopfung Profil / Profil tampon porte / Perfil taponado puerta
8	41411609731V	Profilo tamponazione porta nero / Door filler frame / Türstopfung Profil / Profil tampon porte / Perfil taponado puerta

SUITE HYDROMATIC 24 KW

Componenti interni meccanici ed elettronici / Electronic and mechanic internal parts / Interne mechanische und elektronische Bauteile / Composants internes mécaniques et électroniques / Componentes internos electrónicos y mecánicos

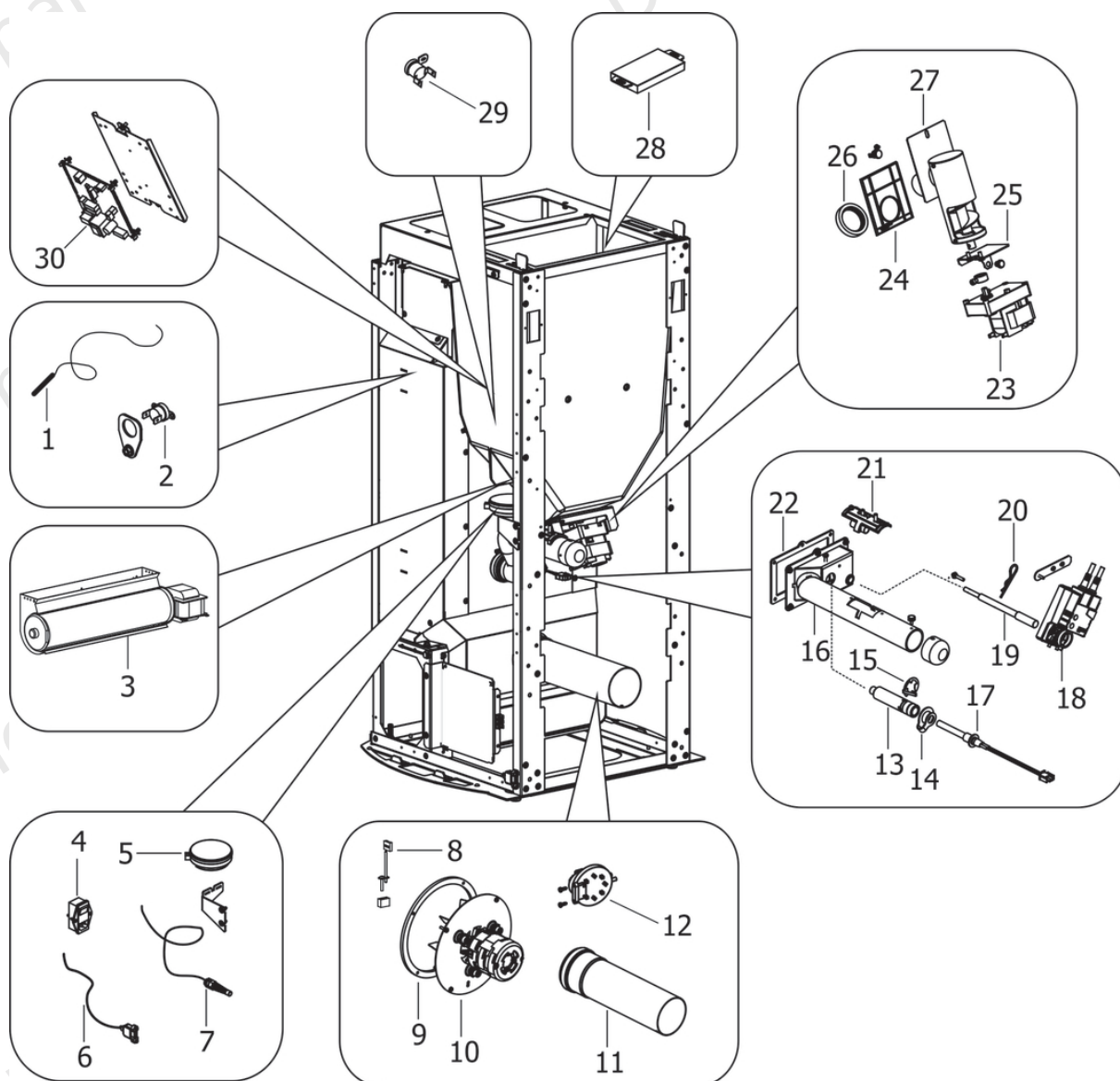

N°	Codice/Code	Descrizioni / Description / Beschreibung / Description / Description
1	4012062	Sonda NTC a filo per acqua / Water temperature sensor / Wassertemperaturfühler / Sonde température eau / Sonda temperatura agua
2	41450901100	Clickson 95°C / Clickson 95°C / Clickson 95°C / Clickson 95°C / Clickson 95°C
3	41451000300	Ventilatore scambiatore aria calda / Hot air exchanger fan / Wärmeluftgebläse / Ventilateur échangeur air chaud / Ventilador intercambiador aire caliente
4	4160193	Pulsante accensione / On/Off button / Zündungstaste / Touche d'allumage / Botón encendido
5	41451303400	Trasduttore di pressione / Pressure transducer / Active-Wandler / Transducteur de pression / Transductor de pression
6	41451403200	Cavo USB da pannello L.500 / USB Cable from display L.500 / USB Kabel von Notfalldisplay L.500 / Câble USB de panneau L.500 / Cable USB del panel L.500
7	4160240	Sonda temperatura ambiente / Room temperature sensor / Raumtemperaturfühler / Sonde température ambiance / Sonda temperatura aire
8	41451404500	Sonda fumi con flangia / Smoke sensor with flange / Rauchsonde mit Flansche / Sonde fumées avec bride / Sonda humos con brida

9	41801301500	Guarnizione ventilatore fumi / Smoke exhaust fan gasket / Dichtung Rauchabsauggebläse / Joint Ventilateur aspiration fumées / Junta ventilador aspiración humos
10	41451600100	Ventilatore fumi senza chiocciola stagno / Air-tight smoke exhausted fan / Luftdicht Rauchgasgebläse / Ventilateur fumées étanche / Ventilador humos hermético
10	41452009200	Encoder per ventilatore fumi marchio EMC / Encoder for EMC smoke fan / Encoder für EMC Rauchgasgebläse / Encoder pour ventilateur des fumées marque EMC / Encoder para ventilador humos marca EMC
11	41601601160	Tubo fumi a innesto Ø80 con guarnizione / Smoke pipe Ø 80 with gasket / Rauchrohr Ø 80 mit Dichtung / Tuyau fumées Ø 80 avec joint / Tubo humos Ø 80 con junta
12	4160482	Pressostato 0,4 mbar / Pressure gauge 0,4 mbar / Druckschalter 0,4 mbar / Pressostat 0,4 mbar / Presostato 0,4 mbar
12	4120631A	Tubicino silicónico - 5m / Silicon tube - 5m / Silikonrohr - 5m / Petit tuyau en silicone - 5m / Tubo silicónico - 5m
13	41601802700	Condotto candelella / Sparkplug Conduit / Zündkerzenkanal / Conduit Bougie / Conducto Bujía
14	41801604300	Guarnizione condotto candelella / Sparkplug conduit gasket / Dichtung Zündkerzenkanal / Joint conduit bougie / Junta conducto bujía
15	41201601500	Anello arresto candelella / Sparkplug stop / Zündkerzestopper / Butée bougie / Tope bujía
16	41411609140V	Supporto sistema braciere autopulente / Self-cleaning grate support / Selbstreinigend Brennertopf Gestell / Support brasero autonettoyant / Soporte brasero en arrabio autolimpiador
17	41451308101	Candelella 315 Watt / Sparkplug 315 Watt / Zündkerze 315 Watt / Bougie 315 Watt / Bujía 315 Watt
17	41451308150	Kit 25 candelella 315 Watt / 25 Sparkplugs 315 Watt kit / Bausatz 25 Zündkerzen 315 Watt / Kit 25 Bougies 315 Watt / Kit 25 Bujías 315 Watt
17	41452009900	Candelella 300 Watt / Sparkplug 300 Watt / Zündkerze 300 Watt / Bougie 300 Watt / Bujía 300 Watt
18	41451600900	Attuatore rotativo / Actuator / Trieb / Actionneur / Actuador
19	41201601300	Asse fondo braciere autopulente / Self-cleaning bottom grate shaft / Selbstreinigend Brennertopf Bolzen / Pivot brasero autonettoyant / Perno brasero autolimpiador
20	41201100300	Copiglia elastica (pz.10) / Splint pin (Pcs.10) / Splint (Stk.10) / Goupille fendue (Pcs.10) / Pasador (Pz.10)
21	41601305051	Componente rilevamento portata aria / Air flow measure component / Bauteil für Messung der Luftmenge / Composant pour la mesuration de la quantité d'air / Componente por la medida de l'aire
22	418008027	Guarnizione / Gasket / Dichtung / Joint / Junta
23	41451204900	Motoriduttore 3,3 RPM / Reduction motor 3,3 RPM / Getriebemotor 3,3 RPM / Motorréducteur 3,3 RPM / Motorreductor 3,3 RPM
24	41801600400	Guarnizione gruppo caricamento / Gasket / Dichtung / Joint / Junta
25	41401606430	Staffa fermo motoriduttore / Reduction motor bracket stop / Getriebemotor Bügelstopper / Butée étrier motorréducteur / Tope zuncho motorreductor
26	41801501900	Guarnizione silicone / Silicon gasket / Silikondichtung / Joint en silicone / Junta en silicóna
26	41801702600	Guarnizione / Gasket / Dichtung / Joint / Junta
27	41411800151	Gruppo alimentazione completo / Complete feed screw / Komplette Förderschnecke / Vis sans fin complète / Coclea de carga completa
28	41451303706	Pannello comandi Hottoh 129 / Control panel Hottoh 129 / Bedienblende Hottoh 129 / Tableau de commande Hottoh 129 / Panel de mandos Hottoh 129
28	41451303600	Cavo connessione pannello / Control panel connection cable / Bedienblende Verbindungskabel / Cable de connection au tableau / Cable de conexión panel de comando
29	412007004	Clickson 110°C / Clickson 110°C / Clickson 110°C / Clickson 110°C / Clickson 110°C
30	41451303805	Scheda madre Hottoh 149 / Hottoh motherboard 149 / Hauptplatine Hottoh 149 / Carte mère Hottoh 149 / Tarjeta madre Hottoh 149
30	41451303807	Scheda madre Hottoh 149 / Hottoh motherboard 149 / Hauptplatine Hottoh 149 / Carte mère Hottoh 149 / Tarjeta madre Hottoh 149
30	41451601000	Cablaggio completo / Complete wiring / Komplette Verkabelung / Câblage complet / Cableado completo
30	41451601002	Cablaggio completo / Complete wiring / Komplette Verkabelung / Câblage complet / Cableado completo
30	41451602300	Cablaggio completo / Complete wiring / Komplette Verkabelung / Câblage complet / Cableado completo

SUITE HYDROMATIC 24 KW

Gruppo scambiatore / Exchanger group / Austausch Baugruppe / Groupe échangeur / Grupo intercambiador

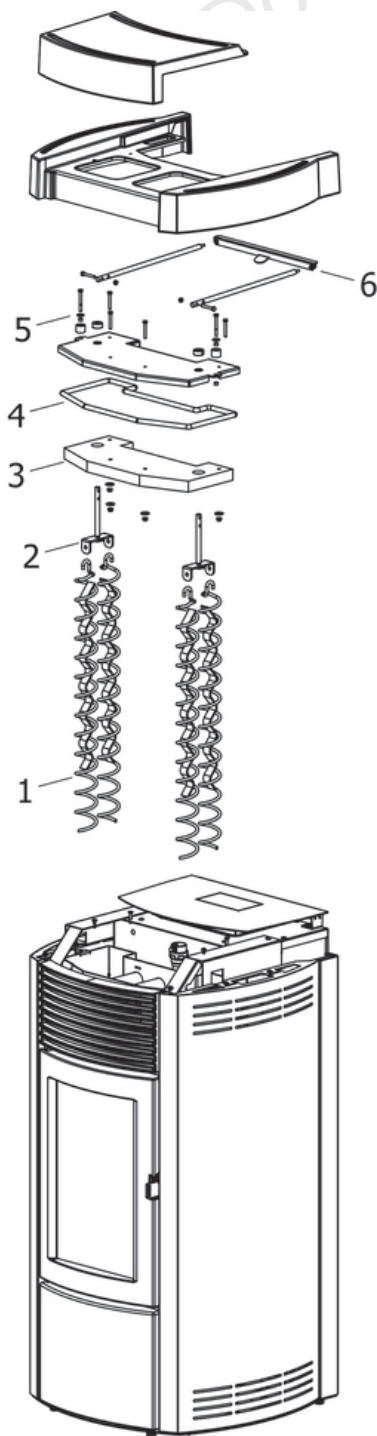

N°	Codice/Code	Descrizioni / Description / Beschreibung / Description / Descripción
1	41400914540	Eliche raschiatore (1 pz.) / Turbulator props (1 pc.) / Propeller des Schabers (1 Teil) / Hélices turbulateur (1 pz.) / Héliche rascador (1 pz.)
2	41401129341	Staffa sostegno raschiatore Inox / Inox turbulator support bar / Haltebügel des Schabers aus Inox / Etrier support turbulateur en Inox / Zuncho apoyo rascador de Inox

3	41151600100	Pannello vermiculite coperchio / Vermiculite cover / Deckel aus Vermiculite / Couvercle en vermiculite / Tapa en vermiculite
4	4120103A	Cordino fibroceramico Ø 10 mm (5 mt.) / Ceramic fibre cord Ø 10 mm (5 m) / Keramikfaserschnur Ø 10 mm (5 m) / Cordon en fibre céramique Ø 10 mm (5 m) / Junta a cuerda de fibra cerámica Ø 10 mm (5 m)
5	41411608940V	Coperchio struttura caldaia nero / Boiler black cover / Schwarz Kelledeckel / Couvercle noir chaudière / Tapa negra caldera
5	41200903300	Trascinatore turbolatori (2 pz.) / Turbolator props puller (2 PC.) / Reinigungsspiralenmitnehmer (2 STCK). / Meneur de turbolateur (2 Pc.) / Arrebatador hélice rascador (2 pz).
5	41801499550	Kit scarico sovrappressione camera di combustione (pz.2) / Pressure relief kit (Pcs.2) / Bausatz überdruckablauf brennkammer (Stck.2) / Kit decompression chambre combustion (Pcs.2) / Kit descompresion camara combustion (Pcs.2)
6	41401605430	Traversa leve movimentazione turbolatori / Tturbolator handling crossbeam / Turbolatorstange Träger / Traverse tige turbolateur / Traversa asta rascador

SUITE HYDROMATIC 24 KW

Componenti interni idraulici **SENZA** kit acqua sanitaria / Internal plumbing components **WITHOUT** domestic water kit / Interne hydraulische Bauteile **OHNE** Brauchwassersatz / Composants hydrauliques internes **SANS** kit eau sanitaire / Componentes internos hidráulicos **SIN** kit de agua sanitaria

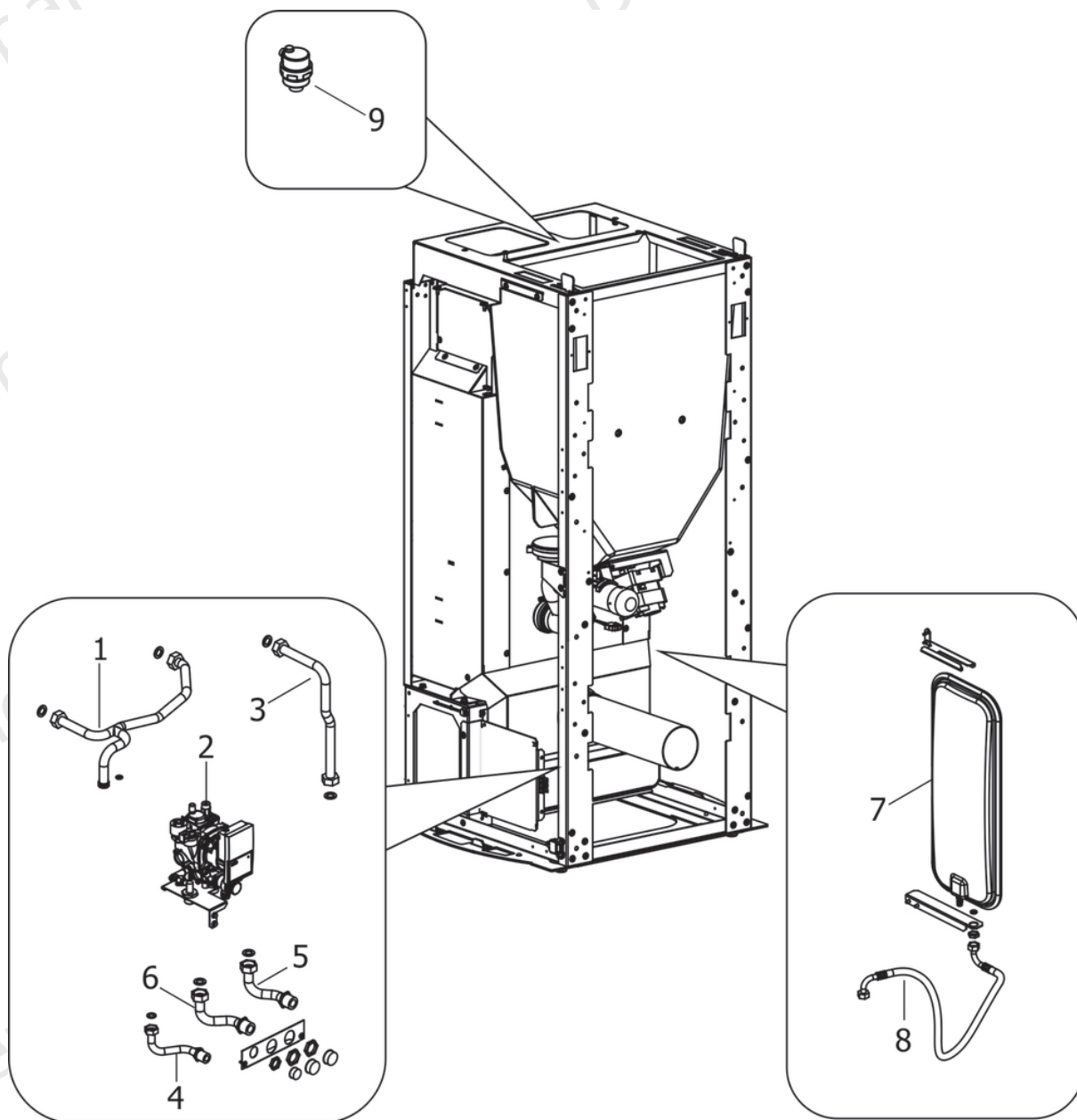

N°	Codice/Code	Descrizioni / Description / Beschreibung / Description / Descripción
1	41501600300	Tubo circolazione caldaia / Boiler circulation tube / Rohr für Kesselumwälzung / Tuyau de circulation chaudière / Tubo de circulación caldera
2	41501600250	Kit idraulico pompa Wilo Yonos Para alta efficienza / Hydraulic kit high efficiency pump Wilo Yonos Para / Hydraulische Baugruppe hoch Effizienz Pumpe Wilo Yonos Para / Kit hydraulique pompe de circulation Wilo Yonos Para haut rendement / Kit fontanero bomba circulación Wilo Yonos Para alto rendimiento
2	41451108000	Pressostato di minima H2O / Pressur switch H2O / Druckwächter H2O / Pressostat H2O / Presostato H2O
2	41501103300	Valvola di sicurezza 3 Bar / Maximum pressure valve 3 Bar / Sicherheitsventil 3 Bar / Soupape de pression maximale 3 Bar / Válvula máxima presión 3 Bar
2	41801204500	Forcella tubo ø18 / Fork pipe ø18 / Gabel-Rohr ø18 / Fourche je roucoule ø18 / Horquilla arrollo ø18
2b	41501600251	Kit idraulico pompa Wilo Para alta efficienza / Hydraulic kit high efficiency pump Wilo Para / Hydraulische Baugruppe hoch Effizienz Pumpe Wilo Para / Kit hydraulique pompe de circulation Wilo Para haut rendement / Kit fontanero bomba circulación Wilo Para alto rendimiento

2b	41502002100	Circolatore Wilo Para 7 IPWM / Water circulation pump Wilo Para 7 IPWM / Umwälzpumpe Wilo Para 7 IPWM / Pompe de circulation Wilo Para 7 IPWM / Bomba de circulación agua Wilo Para 7 IPWM
3	41501600600	Tubo mandata impianto / Delivery tube / Vorlaufrohr / Tuyau refolement / Tubo de envío
4	41501600400	Tubo di carico caldaia / Boiler loading tube / Rohr für Kesselbefüllung / Tuyau de chargement chaudière / Tubo de carga caldera
5	41501600700	Raccordo mandata impianto / Delivery tube connection / Vorlaufrohr Verbindung / Raccord tuyau refolement / Raccor tubo de envío
6	41501600500	Tubo ritorno impianto / Return tube / Rücklaufrohr / Tuyau retour / Tubo de regreso
7	4120775	Vaso espansione (6 l) / Expansion vessel (6 l) / Expansionsgefäß (6 l) / Vase d'expansion (6 l) / Vaso de expansión (6 l)
8	41501601000	Tubo flessibile L.600 / Flexible tube L.600 / Flexibles Rohr L.600 / Tuyau flexible L.600 / Tubo flexible L.600
9	4120779	Valvola di sfogo / Vent valve / Entlüftungsventil / Soupape de dégagement / Válvula respiradero