

## DECO

Componenti Struttura Esterna / External structure components / Bauteile Aussenkorpus / Composants structure externe / Componentes estructura externa

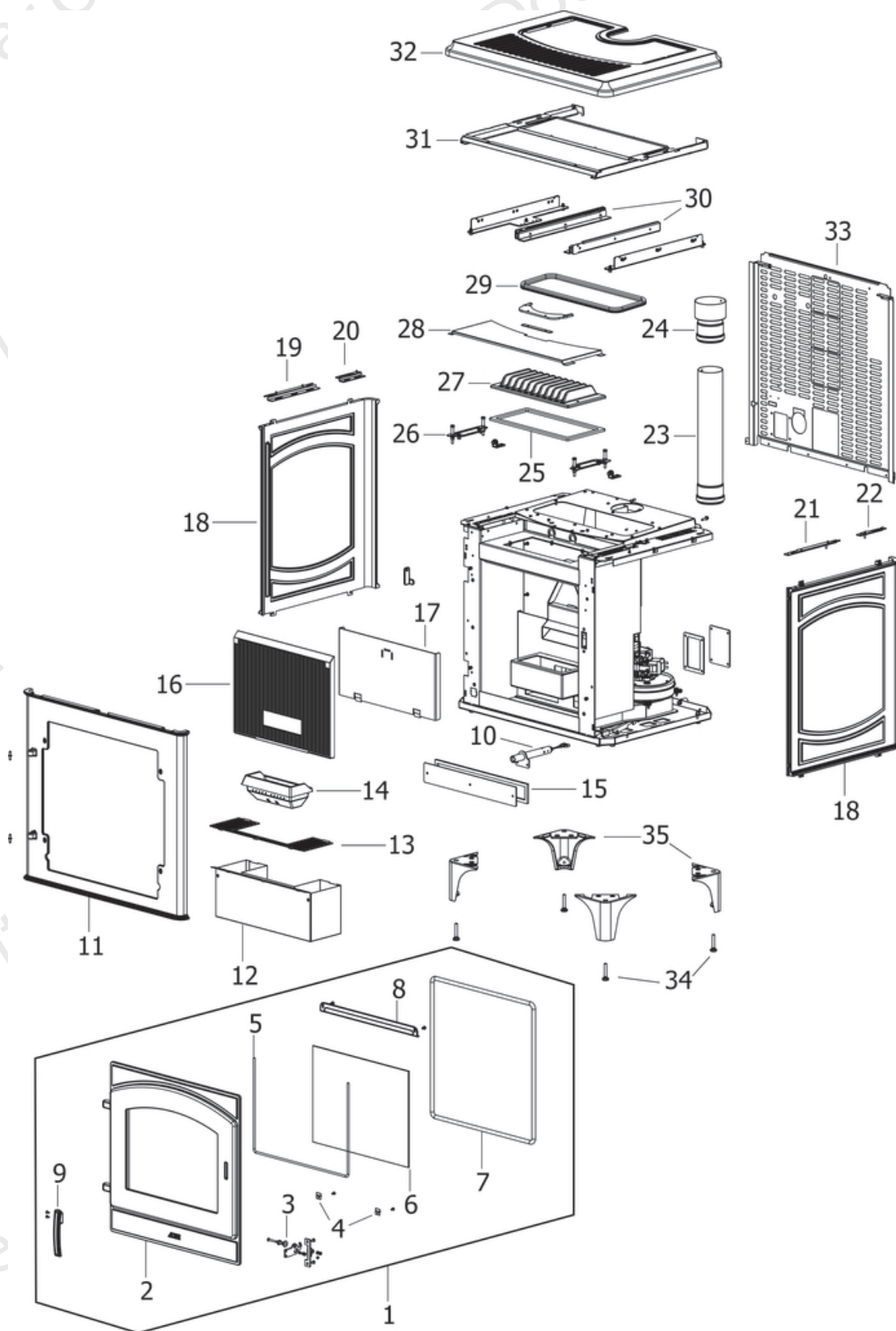

N°	Codice/Code	Descrizioni / Description / Beschreibung / Description / Descripción
1	41301600650	Porta completa SMOKE / Complete door SMOKE / Komplette Tür SMOKE / Porte complète SMOKE / Puerta completa SMOKE
1	41301600750	Porta completa GREEN / Complete door GREEN / Komplette Tür GREEN / Porte complète GREEN / Puerta completa GREEN
1	41301700250	Porta completa White / Complete door White / Komplette Tür White / Porte complète White / Puerta completa White
2	41301501000P	Porta ghisa Smoke / Cast iron complete door SMOKE / Komplette Tür aus Guß SMOKE / Porte complète en fonte SMOKE / Puerta completa de arrabio SMOKE
2	41301501000VE	Porta ghisa Green / Cast iron complete door GREEN / Komplette Tür aus Guß GREEN / Porte complète en fonte GREEN / Puerta completa de arrabio GREEN
2	41301501000BN	Telaio porta in ghisa White / Cast iron door frame White / Türrahmen aus Gusseisen White / Cadre porte en fonte White / Armazón puerta en arrabio White
3	41411602460	Chiusura porta / Door closure / Türschlüsselung / Fermeture porte / Cierre puerta
4	41401077430	Staffe di fissaggio vetroceramico (4 pz.) / Pyroceram fastening brackets (4 pcs.) / Befestigungsbügel Glaskeramik (4 Stck.) / Étrier de fixation vitrocéramique (4 pz.) / Abrazaderas de fijación vidrio cerámico (4 piezas)
5	41201203600A	Cordino Fireglass nero Ø6 (5mt) / Black Fireglass gasket Ø6 (5mt) / Schwarze Dichtung Fireglass Ø6 (5mt) / Joint Fireglass noir Ø6 (5mt) / Junta Fireglass negra Ø6 (5mt)
5	41201203600B	Cordino Fireglass nero Ø6 (50mt) / Black Fireglass gasket Ø6 (50mt) / Schwarze Dichtung Fireglass Ø6 (50mt) / Joint Fireglass noir Ø6 (50mt) / Junta Fireglass negra Ø6 (50mt)
5	41201203600C	Kit cementante + Cordino Fireglass nero Ø6 / Kit cementing + black Fireglass gasket Ø6 / Kit Bindebaustein + Schwarze Dichtung Fireglass Ø6 / Kit cimentaire + Joint Fireglass noir Ø6 / Kit cementante + Junta Fireglass negra Ø6
6	41701600100	Vetroceramico neutro porta / Glass / Glaskeramikscheibe / Vitrocéramique / Cristal cerámico
7	4120103A	Cordino fibrocaramico Ø 10 mm (5 mt.) / Ceramic fibre cord Ø 10 mm (5 m) / Keramikfaserschnur Ø 10 mm (5 m) / Cordon en fibre céramique Ø 10 mm (5 m) / Junta a cuerda de fibra cerámica Ø 10 mm (5 m)
7	4120103B	Cordino fibrocaramico Ø 10 mm (50 mt.) / Ceramic fibre cord Ø 10 mm (50 m) / Keramikfaserschnur Ø 10 mm (50 m) / Cordon en fibre céramique Ø 10 mm (50 m) / Junta a cuerda de fibra cerámica Ø 10 mm (50 m)
7	41201031	Kit sostituzione cordino (cordino+silicone) Ø 10 mm / Cord replacement kit (cord + silicon) Ø 10 mm / Schnur austauschsatz (Schnur+Silikon) Ø 10 mm / Kit remplacement cordon (cordon + silicone) Ø 10 mm / Kit sustitución junta a cuerda (junta a cuerda+silicón) Ø 10 mm
8	41411602230V	Deflettore aria porta / Door deflector / Tür Leitblech / Déflecteur de la porte / Deflektor de la puerta
9	41301501700P	Maniglia ghisa Smoke / Cast iron handle SMOKE / Griff aus Gusseisen SMOKE / Poignée en fonte SMOKE / Tirador de arrabio SMOKE
9	41301501700VE	Maniglia ghisa Green / Cast iron handle GREEN / Griff aus Gusseisen GREEN / Poignée en fonte GREEN / Tirador de arrabio GREEN
9	41301501700BN	Maniglia ghisa White / Cast iron handle White / Griff aus Gusseisen White / Poignée en fonte White / Tirador de arrabio White
10	41401386240V	Condotto candeletta / Sparkplug conduit / Zündkerzenkanal / Conduit bougie / Conducto bujía
11	41301501100P	Frontale ghisa Smoke / Cast iron front panel SMOKE / Vordere Platte aus Guss SMOKE / Plaque frontale en fonte SMOKE / Panel frontal de arrabio SMOKE
11	41301501100VE	Frontale ghisa Green / Cast iron front panel GREEN / Vordere Platte aus Guss GREEN / Plaque frontale en fonte GREEN / Panel frontal de arrabio GREEN
11	41301501100BN	Frontale ghisa White / Cast iron front panel White / Vordere Platte aus Guss White / Plaque frontale en fonte White / Panel frontal de arrabio White
12	41401332050	Cassetto cenere / Ash drawer / Aschenkasten / Tiroir à cendres / Cajón ceniza
13	41401332330V	Griglia focolare / Fire box grille / Feuerstellenrost / Grille foyer / Rejilla hogar
14	41301301400V	Braciere completo in ghisa / cast iron complete grate / Kompletter Brennertopf aus Gusseisen / Brasero complet en fonte / Brasero completo de arrabio
15	41401330910V	Tappo ispezione frontale / Front inspection panel / Vordere Inspektionsoffnung / Trappe de visite frontal / Pantalla de inspección frontal
15	41801404400	Guarnizione / Gasket / Dichtung / Joint / Junta
16	41301501500V	Schiena ghisa / Cast iron back / Rückwand aus Gusseisen / Dossieret en fonte / Parte trasera de arrabio
17	41401331830	Copertura scambiatore interno / Internal exchanger cover / Interne Abdeckung Wärmetauscher / Couverture interieure échangeur / Cobertura interna intercambiador
18	41301501200P	Fianco ghisa Smoke / Cast iron side SMOKE / Seite aus Guß SMOKE / Côté en fonte SMOKE / Placa lateral de arrabio SMOKE
18	41301501200P	Fianco ghisa Smoke / Cast iron side SMOKE / Seite aus Guß SMOKE / Côté en fonte SMOKE / Placa lateral de arrabio SMOKE
18	41301501200VE	Fianco ghisa Green / Cast iron side GREEN / Seite aus Guß GREEN / Côté en fonte GREEN / Placa lateral de arrabio GREEN

18	41301501200VE	Fianco ghisa Green / Cast iron side GREEN / Seite aus Guß GREEN / Côté en fonte GREEN / Placa lateral de arrabio GREEN
18	41301501200BN	Fianco ghisa White / Cast iron side White / Seite aus Guß White / Côté en fonte White / Placa lateral de arrabio White
18	41301501200BN	Fianco ghisa White / Cast iron side White / Seite aus Guß White / Côté en fonte White / Placa lateral de arrabio White
19	41401601330	Staffa bloccaggio fianco anteriore / Frontal side bracket / Vordereseitenteil Bügel / Etrier de fixation côte antérieur / Abrazadera lateral delantero
20	41401601430	Staffa bloccaggio fianco posteriore / Rear side bracket / Hintereseitenteil Bügel / Etrier de fixation côte postérieur / Abrazadera lateral posterior
21	41401601330	Staffa bloccaggio fianco anteriore / Frontal side bracket / Vordereseitenteil Bügel / Etrier de fixation côte antérieur / Abrazadera lateral delantero
22	41401601430	Staffa bloccaggio fianco posteriore / Rear side bracket / Hintereseitenteil Bügel / Etrier de fixation côte postérieur / Abrazadera lateral posterior
23	41601600150	Tube Ø8 L.44 / Tube Ø8 L.44 / Rohr Ø8 L.44 / Tuyau Ø8 L.44 / Tubo Ø8 L.44
24	41601301560	Maggiorazione 80 F / Enlargement 80 F / Vergrößerung 80 F / Majoration 80 F / Aumento 80 F
25	41800802601	Guarnizione / Gasket / Dichtung / Joint / Junta
25	41800802600	Kit 50 guarnizioni / Kit 50 gaskets / Bausatz 50 Dichtungen / Kit 50 joints / Kit 50 juntas
26	41401601150	Staffa supporto rulli / Roll support bracket / Haltebügel Walze / Étrier support rouleau / Zuncho de soporte rodillo
27	41300901100	Scambiatore in ghisa / Cast iron exchanger / Gusseiserne Wärmetauscher / Echangeur en fonte / Intercambiador en arrabio
28	41801600600V	Griglia protezione / Protection grille / Schutzgitter / Grille de protection / Rejilla de protección
29	41801208002	Guarnizione - 2,5 m / Gasket - 2,5 m / Dichtung - 2,5 m / Joint - 2,5 m / Junta - 2,5 m
29	41801208000	Guarnizione - 5 m / Gasket - 5 m / Dichtung - 5 m / Joint - 5 m / Junta - 5 m
29	41801208001	Guarnizione - 50 m / Gasket - 50 m / Dichtung - 50 m / Joint - 50 m / Junta - 50 m
30	41201203801	Guida di scorrimento (coppia) / Sliding runner (pair) / Schubladelaufschiene (Paar) / Rail de guidage (paire) / Guía de deslizamiento (par)
31	41411601240P	Telaio supporto top / Top support frame / Deckelhaltebügel Rahmen / Cadre support du dessus / Armazón soporte top
32	41301501300P	Top ghisa Smoke / Cast iron top SMOKE / Topplatte aus Guß SMOKE / Dessus en fonte SMOKE / Top de arrabio SMOKE
32	41301501300VE	Top ghisa Green / Cast iron top GREEN / Topplatte aus Guß GREEN / Dessus en fonte GREEN / Top de arrabio GREEN
32	41301501300BN	Top ghisa White / Cast iron top White / Topplatte aus Guß White / Dessus en fonte White / Top de arrabio White
33	41411602030P	Fianco sinistro completo / Complete L. side / Komplet links Seite / Côte complet G. / Lateral completo IZDO
34	41201600160	Piedino zincato nero / Galvanized foot / Verzinktes Fus / Vérin zingué / Pie galvanizado
35	41301501600P	Piede ghisa Smoke (4 pz) / Cast iron feet SMOKE (4 pcs.) / Füße aus Gusseisen SMOKE (4 Stck.) / Vérins en fonte SMOKE (4 p.es) / Pies de arrabio SMOKE (4 pz.)
35	41301501600VE	Piede ghisa Green (4 pz) / Cast iron feet GREEN (4 pcs.) / Füße aus Gusseisen GREEN (4 Stck.) / Vérins en fonte GREEN (4 p.es) / Pies de arrabio GREEN (4 pz.)
35	41301501600BN	Piede ghisa White (4 pz) / Cast iron feet White (4 pcs.) / Füße aus Gusseisen White (4 Stck.) / Vérins en fonte White (4 p.es) / Pies de arrabio White (4 pz.)

## DECO

Componenti interni meccanici ed elettronici / Electronic and mechanic internal parts / Interne mechanische und elektronische Bauteile / Composants internes mécaniques et électroniques / Componentes internos electrónicos y mecánicos

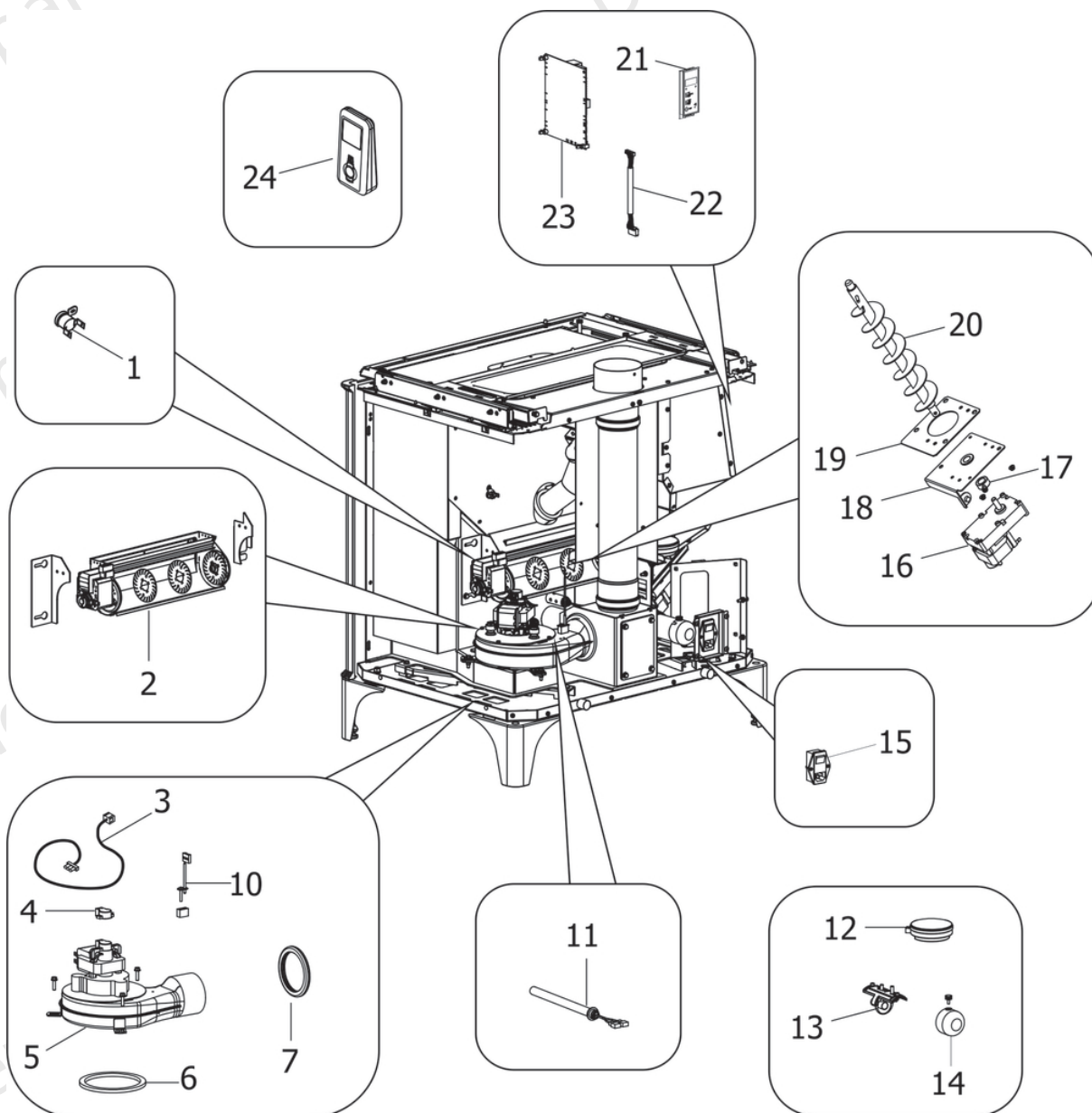

N°	Codice/Code	Descrizioni / Description / Beschreibung / Description / Descripción
1	412007004	Clickson 110°C / Clickson 110°C / Clickson 110°C / Clickson 110°C / Clickson 110°C
2	41451600500	Ventilatore tangenziale / Warm air fan / Luftgebläse / Ventilateur air / Ventilador aire
3	41451600600	Cablaggio completo / Complete wiring / Komplette Verkabelung / Câblage complet / Cableado completo
3	41451600601	Cablaggio completo / Complete wiring / Komplette Verkabelung / Câblage complet / Cableado completo
3	41451700800	Cavo encoder / Encoder cable / Drehzahlmesser kabel / Câble encoder / Cable codificador
4	41451209300	Encoder per ventilatore fumi marchi LN2/SIT / Encoder for LN2/SIT smoke fan / Encoder für LN2/SIT Rauchgasgebläse / Encoder pour ventilateur des fumées marques LN2/SIT / Encoder para ventilador humos marcas LN2/SIT
5	41451600400	Ventilatore fumi con pacco ruote / Smoke exhausted fan / Rauchgasgebläse / Ventilateur fumées / Ventilador humos
5	41801102500	Guarnizione / Gasket / Dichtung / Joint / Junta
6	41801002600	Guarnizione adesiva voluta fumi / Adhesive gasket smoke volute / Haftendichtung Rauchvolute / Joint adhesive volute fumées / Junta adhesiva voluta humos

6	41801599850	Kit 50 guarnizioni / Kit 50 gaskets / Bausatz 50 Dichtungen / Kit 50 joints / Kit 50 juntas
7	41801210200	Guarnizione / Gasket / Dichtung / Joint / Junta
10	41451002300	Sonda fumi con flangia / Smoke sensor with flange / Rauchgasfühler mit Flansche / Sonde fumées avec bride / Sonda humos con arandela
11	41450905000	Candeletta accensione pellet / Pellet ignition sparkplug / Zündkerze Pelletzündung / Bougie d'allumage pellet / Bujía encendido pellet
11	41801599550	Kit 50 candelette / 50 Sparkplugs kit / Bausatz 50 Zündkerzen / Kit 50 Bougies / Kit 50 Bujías
12	41451303400	Trasduttore di pressione / Pressure transducer / Active-Wandler / Transducteur de pression / Transductor de pression
13	41601301851	Componente rilevamento portata aria / Air flow measure component / Bauteil für Messung der Luftmenge / Composent pour la mesuration de la quantité d'air / Componente por la medida de l'aire
14	41401036100	Filtro antipolvere / Anti-dust filter / Staubschutzfilter / Filtre antipoussière / Filtro de protección polvo
15	4160193	Pulsante accensione / On/Off button / Zündungstaste / Touche d'allumage / Botón encendido
16	41451301300	Motoriduttore 1,5 RPM C/ENCODER / Reduction motor 1,5 RPM + ENCODER / Getriebemotor 1,5 RPM + ENCODER / Motoréducteur 1,5 RPM + ENCODER / Motorreductor 1,5 RPM + ENCODER
17	4120398	Connettore motoriduttore-coclea / Reduction motor-feed screw connector / Verbindung Getriebemotor-Schnecke / Connecteur motoréducteur-vis sans fin / Conector motorreductor-cóclea
18	41401421340	Base coclea con boccia / Feed screw base with bush / Untergestell der Förderschnecke mit Buchse / Base de la vis sans fin avec douille / Base de la cóclea con abrazadera
19	4120615	Guarnizione base della coclea / Feed screw base gasket / Dichtung Untergestell der Förderschnecke / Joint pour la base de la vis sans fin / Junta base de la cóclea
20	41201300240	Coclea di caricamento pellet / Pellet feed screw / Pelletsförderschnecke / Vis sans fin pour chargement du pellet / Cóclea de carga pellet
21	41451404100	Pannello emergenza completo di antenna / Emergency display / Notfalldisplay mit Antenne / Panneau d'urgence avec antenne / Panel emergencia con antena
21	41801499750	Kit 868 / Kit 868 / Kit 868 / Kit 868 / Kit 868
22	414508002	Cavo flat 14 vie / Flat cable / Flat-Kabel / Cable flat / Cables flat
23	41451303805	Scheda madre Hottoh 149 / Hottoh motherboard 149 / Hauptplatine Hottoh 149 / Carte mère Hottoh 149 / Tarjeta madre Hottoh 149
23	41451303807	Scheda madre Hottoh 149 / Hottoh motherboard 149 / Hauptplatine Hottoh 149 / Carte mère Hottoh 149 / Tarjeta madre Hottoh 149
23	41801499750	Kit 868 / Kit 868 / Kit 868 / Kit 868 / Kit 868
24	41451301203	Telecomando nero 434,5MHZ - Funzione impostabile da 0 a 3 Ventilatori / Black remote control 434,5MHZ - From 0 to 3 fan function / Schwarze Fernbedienung 434,5MHZ - Von 0 bis 3-Gebläse-Steuerung / Télécommande noire 434,5MHZ - Fonctionne à partir de 0 à 3 Ventilateurs / Mando a distancia negro 434,5MHZ - Función de 0 a 3 ventiladores
24	41801499750	Kit 868 / Kit 868 / Kit 868 / Kit 868 / Kit 868