

JOY

Componenti Struttura Esterna / External structure components / Bauteile Aussenkorpus / Composants structure externe / Componentes estructura externa

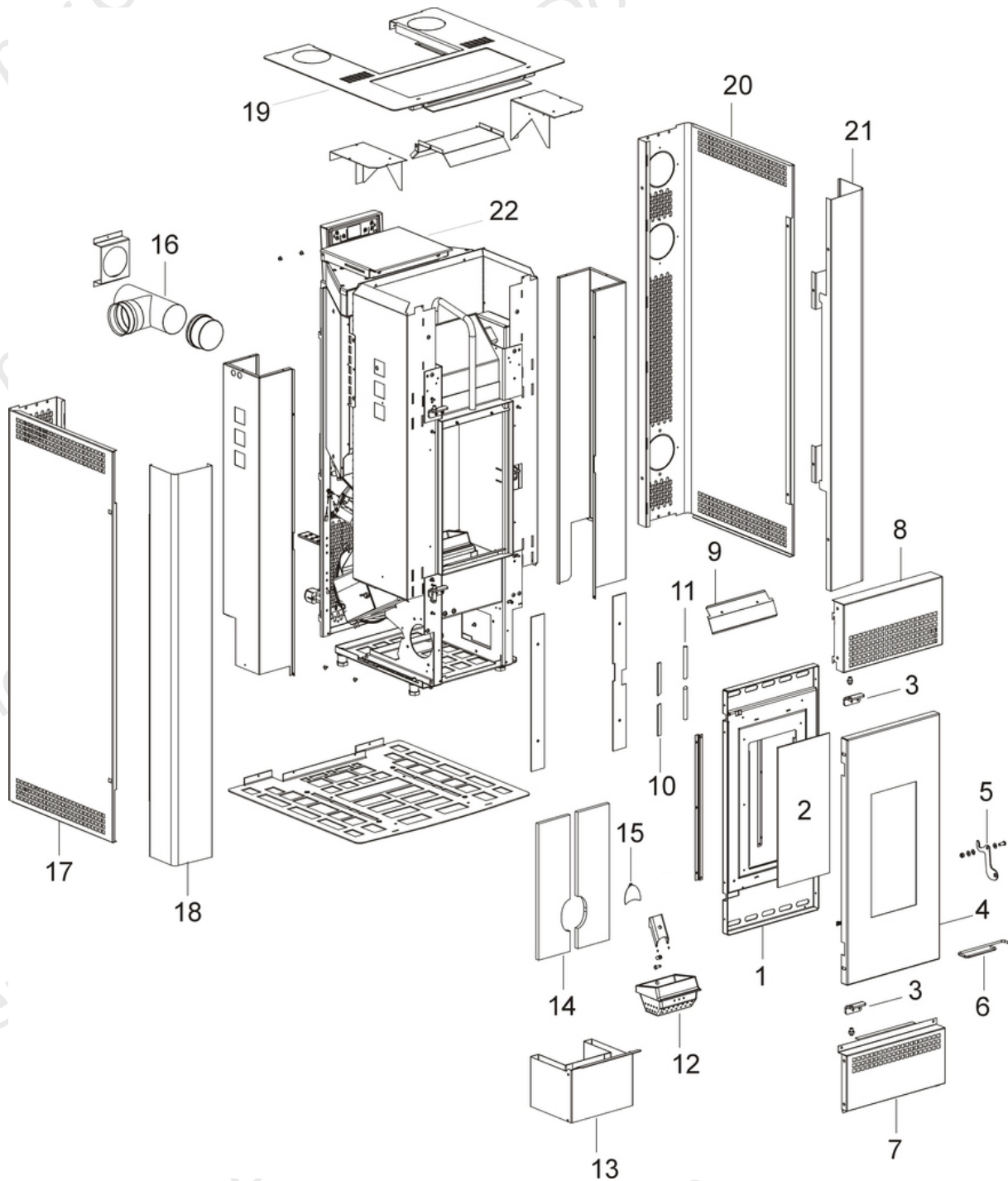

N°	Codice/Code	Descrizioni / Description / Beschreibung / Description / Descripcion
1	4D24014064461	Telaio porta fuoco / Fire door frame / Feuertürrahmen / Cadre porte foyer / Armazón puerta hogar
2	4D170140010	Vetroceramico 385x175x4 mm / Glass 385x175x4 mm / Glaskeramikscheibe 385x175x4 mm / Vitrocéramique 385x175x4 mm / Cristal cerámico 385x175x4 mm
2	4D170157040	Vetroceramico 379x193x4 / Ceramic glass 379x193x4 / Glaskeramikscheibe 379x193x4 / Vitrocéramique 379x193x4 mm / Cristal cerámico 379x193x4 mm
3	4D2401303720	Supporto porta nero / Black door support / Schwarzes Türhaltebügel / Support porte noir / Soporte puerta negro
4	4D24014048361	Telaio porta esterna / External door frame / Außentürrahmen / Cadre porte extérieure / Armazón puerta exterior

4	4D13015701061	Telaio porta fuoco in ghisa / Cast iron fire door frame / Feuertürrahment aus Guß / Cadre porte foyer en fonte / Armazón puerta hogar de arrabio
4	4D245GP16009	Porta fuoco completa / Complete fire door / Komplette Feurtür / Porte foyer complète / Puerta hogar completa
5	4D24014066161	Maniglia / Handle / Griff / Poignée / Tirador
5	4D24015841361	Kit decompressione camera di combustione / Pressure relief kit / Bausatz Überdruckablauf Brennkammer / Kit decompression chambre de combustion / Kit decompression cámara de combustión
6	4D12013060	Gancio "Mano fredda" / Hook "Cold hand" / Haken "Kalte Hand" / Crochet "Main froide" / Gancho "mano fría"
7	4D24014932363	Frontalino inferiore Nero 80° / Black lower filler 80° / Vorderes untere Paneel 80° / Plaque frontale inférieure noir 80° / Tapa inferior negra 80°
8	4D24014934361	Frontalino superiore Nero 500° / Black upper filler 500° / Vorderes obere Paneel 500° / Plaque frontale supérieur noir 500° / Tapa superior negra 500°
9	4D242157093	Deflettore aria porta / Door air deflector / Luftleitblech Tür / Deflecteur air porte / Deflector aire puerta
10	4D18013021A	Guarnizione treccia nera D.10 - 5 M / Black twist gasket D.10 - 5 M / Dichtung D.10 - 5 M / Joint tresse noire D.10 - 5 M / Junta D.10 - 5 M
10	4D18013021B	Guarnizione treccia nera D.10 - 50 M / Black twist gasket D.10 - 50 M / Dichtung D.10 - 50 M / Joint tresse noire D.10 - 50 M / Junta D.10 - 50 M
11	4D18013008A	Guarnizione 10x3 (5m) / Gasket 10x3 (5m) / Dichtung 10x3 (5m) / Joint 10x3 (5m) / Junta 10x3 (5m)
11	4D18013008C	Guarnizione 10x3 (100m) / Gasket 10x3 (100m) / Dichtung 10x3 (100m) / Joint 10x3 (100m) / Junta 10x3 (100m)
12	413008003	Braciere completo in ghisa / Cast iron complete grate / Kompletter Brennertopf aus Gusseisen / Brasero complet en fonte / Brasero completo de arrabio
12	4D13016602061	Braciere / Grate / Brennschale / Brasero / Brasero
13	4D24014015461	Cassetto cenere / Ash drawer / Aschenkasten / Tiroir à cendres / Cajón ceniza
14	4D115140020	Schiena in Calorite (2pz) / Calorite back (2 Pcs) / Rückwand aus Calorite (2 Stk) / Fond en Calorite (2 Pcs) / Parte trasera de Calorite (2 Pz)
15	4D2401303101	Deflettore pellet / Pellet deflector / Pellet Leitblech / Deflecteur pellet / Deflector pellet
16	4D14013065	Tappo raccordo D. 80 / Junction plug D.80 / Anschlussdeckel D.80 / Bouchon de raccordement D.80 / Tapón raccor D.80
16	4D160140070	Raccordo a "T" + Guarnizione / T-Union + Gasket / T-Stück + Dichtung / Raccord en "T" + joint / Tuvería en te + Junta
17	4D24014931363	Fianco posteriore Nero 80° / Black 80° rear side / Hintere Schwarze Seite 80° / Côté postérieur noir 80° / Lateral posterior Negro 80°
18	4D24014930346	Fianco anteriore Silver HJT / Silver HJT front side / Vordere Silberne HJT Seite / Côté antérieur Argent / Lateral frontal Silver HJT
19	4D24014936461	Top Nero 500° / Top black 500° / Schwarzes Topplatte 500° / Dessus noir 500° / Top negro 500°
20	4D24014931363	Fianco posteriore Nero 80° / Black 80° rear side / Hintere Schwarze Seite 80° / Côté postérieur noir 80° / Lateral posterior Negro 80°
21	4D24014930346	Fianco anteriore Silver HJT / Silver HJT front side / Vordere Silberne HJT Seite / Côté antérieur Argent / Lateral frontal Silver HJT
22	4D18013016	Guarnizione 155X190 mm / Gasket 155X190 mm / Dichtung 155x190 mm / Joint 155X190 mm / Junta 155X190 mm
22	4D24014020361	Coperchio serbatoio pellet / Pellet hopper cover / Deckel Pelletbehälter / Couvercle réservoir pellet / Tapadera depósito

JOY

Componenti interni meccanici ed elettronici / Electronic and mechanic internal parts / Interne mechanische und elektronische Bauteile / Composants internes mécaniques et électroniques / Componentes internos electrónicos y mecánicos

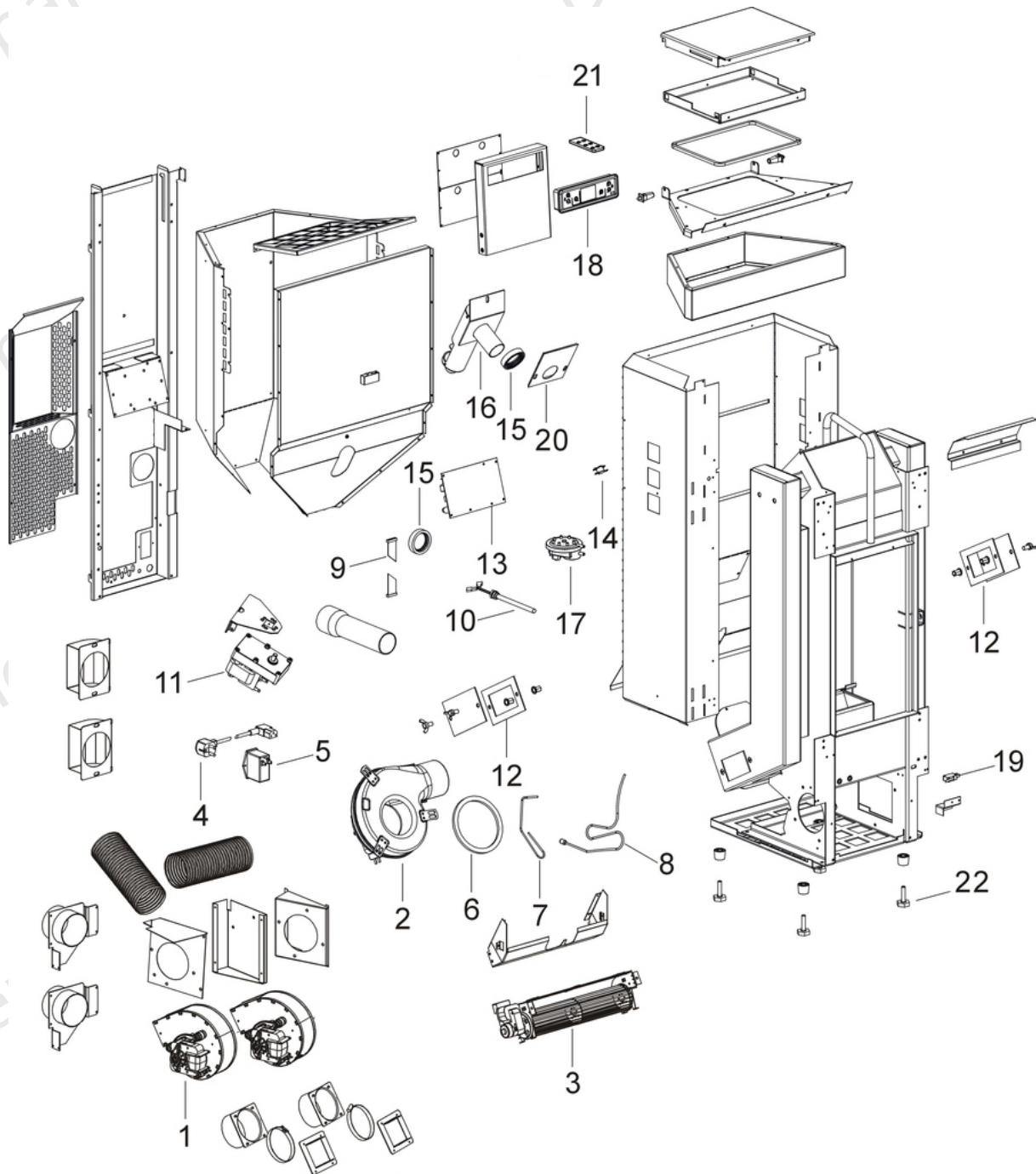

N°	Codice/Code	Descrizioni / Description / Beschreibung / Description / Descripción
1	4D145201070	Ventilatore aria / Air fan / Luftgebläse / Ventilateur air / Ventilador aire
2	4D145140150	Ventilatore fumi stagno / Air-tight smoke exhausted fan / Luftdichtes Rauchgasgebläse / Ventilateur fumées étanche / Ventilador humos hermético
2	41801600800	Guarnizione ventilatore fumi / Smoke exhaust fan gasket / Dichtung Rauchabsauggebläse / Joint Ventilateur aspiration fumées / Junta ventilador aspiración humos
2	41451209300	Encoder per ventilatore fumi marchi LN2/SIT / Encoder for LN2/SIT smoke fan / Encoder für LN2/SIT Rauchgasgebläse / Encoder pour ventilateur des fumées marques LN2/SIT / Encoder para ventilador humos marcas LN2/SIT

3	4D14513004	Ventilatore aria / Air fan / Luftgebläse / Ventilateur air / Ventilador aire
4	4D14513041	Cavo alimentazione / Power source cable / Zündungskabel / Câble alimentation / Cable alimentación
5	4D14513090	Pulsante accensione / On/Off button / Zündungstaste / Touche d'allumage / Botón encendido
6	4D18013024	Guarnizione / Gasket / Dichtung / Joint / Junta
7	4D145150090	Sonda fumi / Smoke sensor / Rauchsonde / Sonde fumées / Sonda humos
8	4D145150110	Sonda ambiente / Room temperature sensor / Raumtemperaturfühler / Sonde température ambiance / Sonda ambiente
9	4D14513007	Cavo flat scheda-pannello / Flat cable motherboard-control panel / Flat Kabel Hauptplatine-Bedienblende / Câble flat carte mère-panneau commande / Cable flat tarjeta madre-panel de mandos
10	4D14513002	Candeletta / Sparkplug / Zündkerze Pelletzündung / Bougie / Bujía encendido pellet
10	4D145181040	Candeletta / Sparkplug / Zündkerze / Bougie / Bujía
11	4D145159010	Motoriduttore 3,3 rpm / Reduction motor 3,3 rpm / Getriebemotor 3,3 rpm / Motoréducteur 3,3 rpm / Motorreductor 3,3 rpm
11	4D145181020	Motoriduttore 2 rpm / Reduction motor 2 rpm / Getriebemotor 2 rpm / Motoréducteur 2 rpm / Motorreductor 2 rpm
12	4D18013001	Guarnizione 130x80 mm / Gasket 130x80 mm / Dichtung 130x80 mm / Joint 130x80 mm / Junta 130x80 mm
12	4D18013001	Guarnizione 130x80 mm / Gasket 130x80 mm / Dichtung 130x80 mm / Joint 130x80 mm / Junta 130x80 mm
13	4D14513064B	Scheda madre / Motherboard / Hauptplatine / Carte mère / Tarjeta madre
13	4D145181060	Scheda madre L023-V5-64K / Motherboard L023-V5-64K / Hauptplatine L023-V5-64K / Carte mère L023-V5-64K / Tarjeta madre L023-V5-64K
14	4D14513006	Termostato 60°C / Thermostat 60°C / Thermostat 60°C / Thermostat 60°C / Termostato 60°C
15	4D18013003	Guarnizione D.50 mm / Gasket D.50 mm / Dichtung D.50 mm / Joint D.50 mm / Junta D.50 mm
15	4D18013003	Guarnizione D.50 mm / Gasket D.50 mm / Dichtung D.50 mm / Joint D.50 mm / Junta D.50 mm
16	4D140160030	Coclea di caricamento pellet / Pellet feed screw / Pelletsförderschnecke / Vis sans fin pour chargement du pellet / Cóclea de carga pellet
16	4D180177070	Coclea di caricamento pellet / Pellet feed screw / Pelletsförderschnecke / Vis sans fin pour chargement du pellet / Cóclea de carga pellet
16	4D180177010	Boccola / Bushing / Buchse / Douille / Abrazadera
17	4120631A	Tubicino siliconico - 5m / Silicon tube - 5m / Silikonrohr - 5m / Petit tuyau en silicone - 5m / Tubo silicónico - 5m
17	4160482	Pressostato 0,4 mbar / Pressure gauge 0,4 mbar / Druckwächter 0,4 mbar / Pressostat 0,4 mbar / Presostato 0,4 mbar
18	4D14513032	Pannello comandi / Control panel / Bedienblende / Tableau de commande / Panel de mandos
18	4D1451303300	Pannello comandi grafico / Graphic control panel / Graphische Bedienblende / Tableau de commande / Panel de mandos gráfico
19	4D14513030	Interruttore di sicurezza della porta fuoco / Fire door safety switch / Microswitch / Interrupteur de sécurité porte foyer / Microswitch
20	4D18013004	Guarnizione 100X108 mm / Gasket 100X108 mm / Dichtung 100x108 mm / Joint 100X108 mm / Junta 100X108 mm
21	5019012	Telecomando / Remote control / Fernbedienung / Télécommande / Mando a distancia
22	4D12013006	Piedini di appoggio (4 pz.) / Support feet (4 pcs.) / Einstellfüße (4 Stck.) / Vérins (4 pcs) / Pies de apoyo (4 pzs)
23	4D241140013	Carter posteriore / Back carter / Hinteres Blech / Protection arrière / Carter trasero