

COMPACT SLIM 15

Componenti Struttura Esterna / External structure components / Bauteile Aussenkorpus / Composants structure externe / Componentes estructura externa

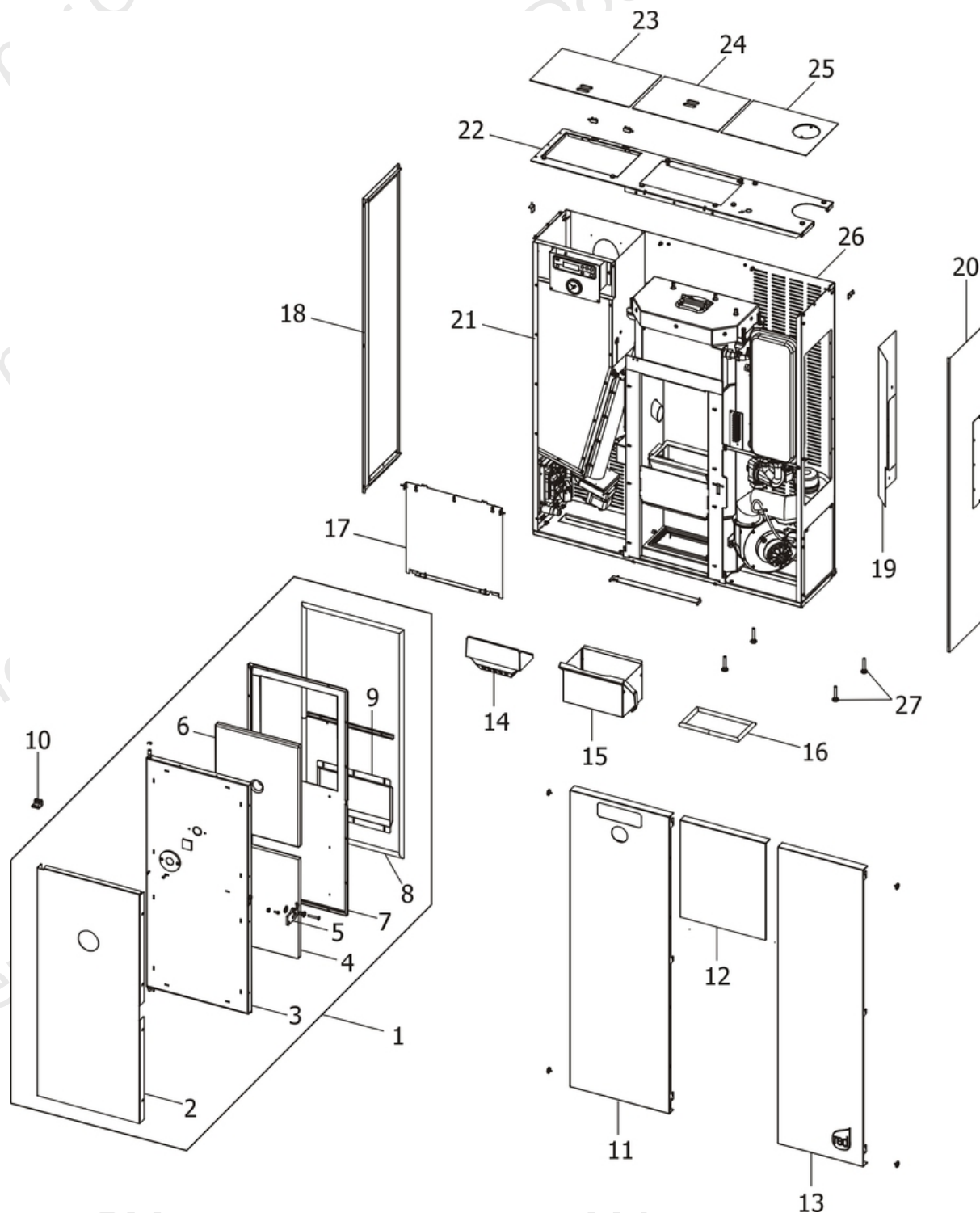

N°	Codice/Code	Descrizioni / Description / Beschreibung / Description / Description
1	41401343450	Porta finita completa / Complete finished door / Komplette Tür / Porte finie complète / Puerta completa
2	41401344161	Telaio esterno porta fuoco / External door frame / Aussere Feuertürrahmen / Cadre extérieure porte / Armazón externo puerta
3	41401343540V	Telaio interno porta fuoco / Internal door frame / Innere Feuertürrahmen / Cadre intérieure porte / Armazón interno puerta

4	41151300800	Isolante interno inferiore / Lower internal insulating material / Innerer unterer Isolationsmaterial / Isolant intérieur inférieur / Aislante interno inferior
5	41401354360	Maniglia / Handle / Griff / Poignée / Tirador
6	41151300700	Isolante interno superiore / Upper internal insulating material / Innerer oberer Isolationsmaterial / Isolant intérieur supérieur / Aislante interno superior
7	41401344030	Tamponazione interna porta fuoco / Fire door inner filling / Interne Abdichtung Feuerraumtür / Tampon interne de la porte du foyer / Taponado interno de la puerta hogar
8	412007003A	Cordino fibroceramico Ø 14 mm (5 mt.) / Ceramic fibre cord Ø 14 mm (5 m.) / Keramikfaserschnur Ø 14 mm (5 m) / Cordon en fibre céramique Ø 14 mm (5 m) / Junta a cuerda de fibra cerámica Ø 14 mm (5 m)
8	412007003B	Cordino fibroceramico Ø 14 mm (50 mt.) / Ceramic fibre cord Ø 14 mm (50 m.) / Keramikfaserschnur Ø 14 mm (50 m) / Cordon en fibre céramique Ø 14 mm (50 m) / Junta a cuerda de fibra cerámica Ø 14 mm (50 m)
8	412007003C	Kit sostituzione cordino (cordino+silicone) Ø 14 mm / Cord replacement kit (cord + silicon) Ø14 mm / Schnuraustauschsatz (Schnur +Silikon) Ø 14 mm / Kit remplacement cordon (cordon+silicon) Ø 14 / Kit sustitución junta a cuerda (junta a cuerda+silicón) Ø 14 mm
9	41401376430	Parete inter. batt. cassetto cenere / Internal wall for ashes / Innen Blechwand Aschenkastenlager / Paroi interne/Chendrier / Pared interior cenicero
10	41401326330V	Cerniera porta / Door anchoring / Federscharnier / Charnière / Bisagra
11	41401344250	Frontale lato SX / Frontal cladding L. / Vordere LI. Verkleidung / Revêtement frontal D. / Revestimiento frontal IZDO
12	41401344650	Frontale centrale / Central frontal cladding / Vordere Frontale Verkleidung / Revêtement frontal central / Revestimiento frontal central
13	41401344550	Frontale lato DX / Frontal cladding R. / Vordere RE. Verkleidung / Revêtement frontal D. / Revestimiento frontal DCHO
14	41301300100V	Braciere completo in ghisa / cast iron complete grate / Kompletter Brennerkopf aus Gusseisen / Brasero complet en fonte / Brasero completo de arrabio
15	41401341630	Cassetto cenere / Ash drawer / Aschenkasten / Tiroir à cendres / Cajón ceniza
16	412007003A	Cordino fibroceramico Ø 14 mm (5 mt.) / Ceramic fibre cord Ø 14 mm (5 m.) / Keramikfaserschnur Ø 14 mm (5 m) / Cordon en fibre céramique Ø 14 mm (5 m) / Junta a cuerda de fibra cerámica Ø 14 mm (5 m)
16	412007003B	Cordino fibroceramico Ø 14 mm (50 mt.) / Ceramic fibre cord Ø 14 mm (50 m.) / Keramikfaserschnur Ø 14 mm (50 m) / Cordon en fibre céramique Ø 14 mm (50 m) / Junta a cuerda de fibra cerámica Ø 14 mm (50 m)
16	412007003C	Kit sostituzione cordino (cordino+silicone) Ø 14 mm / Cord replacement kit (cord + silicon) Ø14 mm / Schnuraustauschsatz (Schnur +Silikon) Ø 14 mm / Kit remplacement cordon (cordon+silicon) Ø 14 / Kit sustitución junta a cuerda (junta a cuerda+silicón) Ø 14 mm
17	41401342330V	Tamponazione frontale / Frontal filler / Vordere Stopfung / Plaque frontal / Tapa frontal
18	41401345160	Fianco laterale SX / Side panel L. / Seitenteil LI. / Côté G. / Lado IZDO
19	41401324330	Pannello protezione vano idraulico / Hydraulic Unit protection panel / Schutzpaneel Hydraulik / Panneau de protection allogement hydraulic / Panel de proteccion vano hidráulico
20	41401344850	Fianco laterale DX / Side panel R. / Seitenteil RE. / Côté D. / Lado DCHO
21	437013033	Serbatoio pellet / Pellet Hopper / Pelletbehälter / Réservoir pellet / Depósito pellet
22	41401342230V	Supporto top superiore acciaio / Steel upper top support / Deckelhaltebügel aus Stahl / Support du dessus en acier / Soporte del top en acero
23	41401345260	Coperchio serbatoio pellet / Pellet hopper cover / Deckel Pelletbehälter / Couvercle réservoir pellet / Tapadera depósito pellas de madera
24	41401345360	Coperchio vano turbolatori / Turbolators cover / Reinigungspiralenlager Abdeckung / Couvercle allogement turbolateurs / Tapa vano turboladores
25	41401345560	Coperchio tubo uscita fumi / Smoke outlet pipe cover / Obere Abgasrohraustritt Abdeckung / Couvercle sortie fumée / Tapa salida humos
26	41401342111	Schiena posteriore nera / Black Back / Hintere schwarze Rückwand / Dossieret postérieur noir / Parte trasera posterior negra
27	41200906660	Piedini di appoggio (4 pz.) / Support feet (4 pcs.) / Einstellfüße (4 Stck.) / Vérins d'appui (4 p.es) / Pies de apoyo (4 piezas)

COMPACT SLIM 15

Componenti interni meccanici ed elettronici / Electronic and mechanic internal parts / Interne mechanische und elektronische Bauteile / Composants internes mécaniques et électroniques / Componentes internos electrónicos y mecánicos

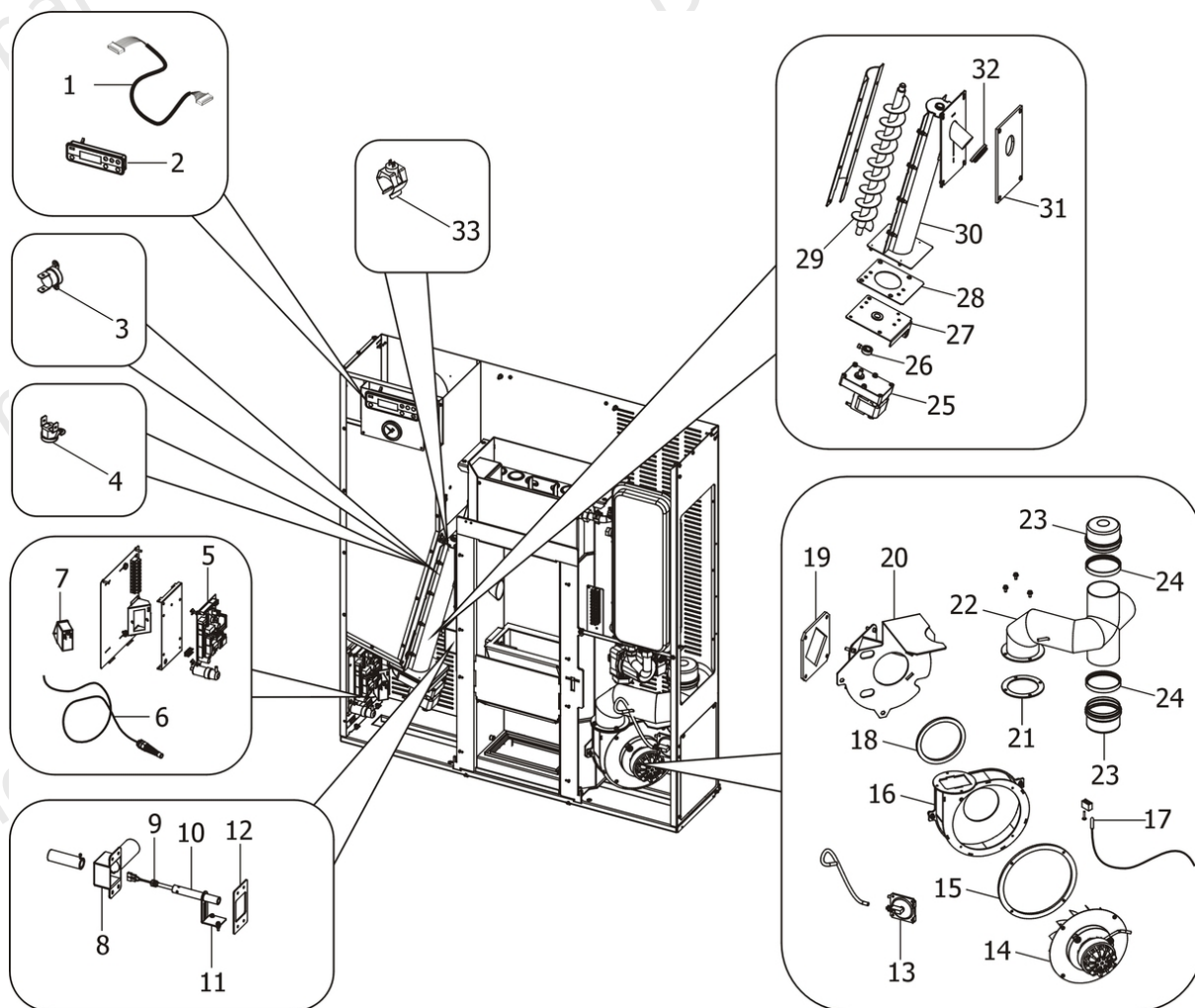

N°	Codice/Code	Descrizioni / Description / Beschreibung / Description / Description
1	41451201900	Cavo Flat L 1,4 M / Flat cable L 1,4 M / Flat Kable L 1,4 M / Câble Flat L 1,4 M / Cable Flat L 1,4 M
2	41451200600	Pannello comandi / Control panel / Bedienblende / Panneau de commande / Panel de mandos
3	412007004	Clickson 110°C / Clickson 110°C / Clickson 110°C / Clickson 110°C / Clickson 110°C
4	41451107300	Clickson 95°C / Clickson 95°C / Clickson 95°C / Clickson 95°C / Clickson 95°C
5	41451200500	Scheda madre completa MICRONOVA / Complete mother board MICRONOVA / Komplette Hauptplatine MICRONOVA / Carte mère complete MICRONOVA / Tarjeta madre completa MICRONOVA
5	41451200500B	Scheda madre non programmata MICRONOVA / Unprogrammed motherboard MICRONOVA / Unprogrammierte Hauptplatine MICRONOVA / Carte mère non programmée MICRONOVA / Tarjeta madre sin programa MICRONOVA
6	4160386	Sonda temperatura ambiente/acqua / Room/Water temperature sensor / Raum- Wassertemperaturfühler / Sonde température ambiance/eau / Sonda temperatura ambiente/agua
7	41451107400	Pulsante accensione / On/Off button / Zündungstaste / Touche d'allumage / Botón encendido
8	41401323640V	Innesto tubo aria comburente / Intake air pipe graft / Kopplung Verbrennungsluftrohr / Emboitement sortie fumée / Embocadura aire comburente
9	41451802900	Candeletta 315 Watt / Sparkplug 315 Watt / Zündkerze 315 Watt / Bougie 315 Watt / Bujía 315 Watt
10	41601000600	Condotto candeletta / Sparkplug conduit / Zündkerzenkanal / Conduit bougie / Conducto bujía
11	41401323830	Supporto condotto candeletta / Sparkplug conduit support / Zündkerzenkanal Haltebügel / Support conduit bougie / Soporte conducto bujía
12	41801201500	Guarnizione tappi ispezione / Gasket inspection plugs / Dichtung Inspektionsklappe / Joint clapets inspections / Junta tapónes inspección

13	414508040	Pressostato 1.2 mbar / Pressure switch 1.2 mbar / Druckwächter 1.2 mbar / Pressostat 1.2 mbar / Presostato 1.2 mbar
14	414508016	Ventilatore aspirazione fumi con encoder / Smoke exhaust fan WITH encoder / Rauchabsauggebläse MIT Encoder / Ventilateur aspiration fumées AVEC encoder / Ventilador aspiración humos con codificador
15	41801301500	Guarnizione ventilatore fumi / Smoke exhaust fan gasket / Dichtung Rauchabsauggebläse / Joint Ventilateur aspiration fumées / Junta ventilador aspiración humos
16	41401312340V	Voluta ventilatore estrazione fumi / Volute smoke exhausted fan / Volute Rauchgasgebläse / Volute ventilateur fumées / Voluta ventilador humos
17	41451002300	Sonda fumi con flangia / Smoke sensor with flange / Rauchgasfühler mit Flansche / Sonde fumées avec bride / Sonda humos con arandela
18	41801002600	Guarnizione adesiva voluta fumi / Adhesive gasket smoke volute / Haftendichtung Rauchvolute / Joint adhesive volute fumées / Junta adhesiva voluta humos
18	41801599850	Kit 50 guarnizioni / Kit 50 gaskets / Bausatz 50 Dichtungen / Kit 50 joints / Kit 50 juntas
19	41801300300	Guarnizione / Gasket / Dichtung / Joint / Junta
20	41401323940V	Raccordo condotto fumi / Smoke duct connection / Abgasrohranschluss / Raccord conduit fumées / Raccor canal humos
21	41801001700	Guarnizione / Gasket / Dichtung / Joint / Junta
21	418010017001	Kit 50 guarnizioni / Kit 50 gaskets / Bausatz 50 Dichtungen / Kit 50 joints / Kit 50 juntas
22	41601300161	Tubo uscita fumi / Smoke outlet pipe / Rohr Rauchabzug / Tuyau sortie fumées / Tubo salida humos
23	41601303600V	Tappo uscita fumi / Smoke outlet plug / Rauchabsaugdeckel / Trappe sortie des fumées / Tapón salida humos
23	41601303600V	Tappo uscita fumi / Smoke outlet plug / Rauchabsaugdeckel / Trappe sortie des fumées / Tapón salida humos
24	40120969	Guarnizione silicone (5pz) / Silicone Gasket (5pc.) / Silikondichtung (5 St.) / Joint en silicone / Junta en silicona
24	40120969	Guarnizione silicone (5pz) / Silicone Gasket (5pc.) / Silikondichtung (5 St.) / Joint en silicone / Junta en silicona
25	41451204900	Motoriduttore 3,3 RPM / Reduction motor 3,3 RPM / Getriebemotor 3,3 RPM / Motoréducteur 3,3 RPM / Motorreductor 3,3 RPM
26	4120896	Connettore motoriduttore-coclea / Reduction motor-feed screw connector / Verbindung Getriebemotor-Schnecke / Connecteur motoréducteur-vis sans fin / Conector motorreductor-cóclea
27	41400944351	Base della coclea / Feed screw base / Untergestell der Förderschnecke / Base de la vis sans fin / Base de la cóclea
28	4120615	Guarnizione base della coclea / Feed screw base gasket / Dichtung Untergestell der Förderschnecke / Joint pour la base de la vis sans fin / Junta base de la cóclea
29	41201300540	Coclea di caricamento pellet / Pellet feed screw / Pelletsförderschnecke / Vis sans fin pour chargement du pellet / Cóclea de carga pellet
30	41401323140V	Condotto della coclea / Conduit of feed screw / Rohrleitung der Förderschnecke / Conduit de la vis sans fin / Conducto de la cóclea
31	41801300100	Guarnizione / Gasket / Dichtung / Joint / Junta
32	41801210100	Guarnizione / Gasket / Dichtung / Joint / Junta
33	41450901200	Sonda temperatura acqua / Water temperature sensor / Wassertemperaturfühler / Sonde température eau / Sonda temperatura agua

COMPACT SLIM 15

Componenti interni idraulici **SENZA** kit acqua sanitaria / Internal plumbing components **WITHOUT** domestic water kit / Interne hydraulische Bauteile **OHNE** Brauchwassersatz / Composants hydrauliques internes **SANS** kit eau sanitaire / Componentes internos hidráulicos **SIN** kit de agua sanitaria

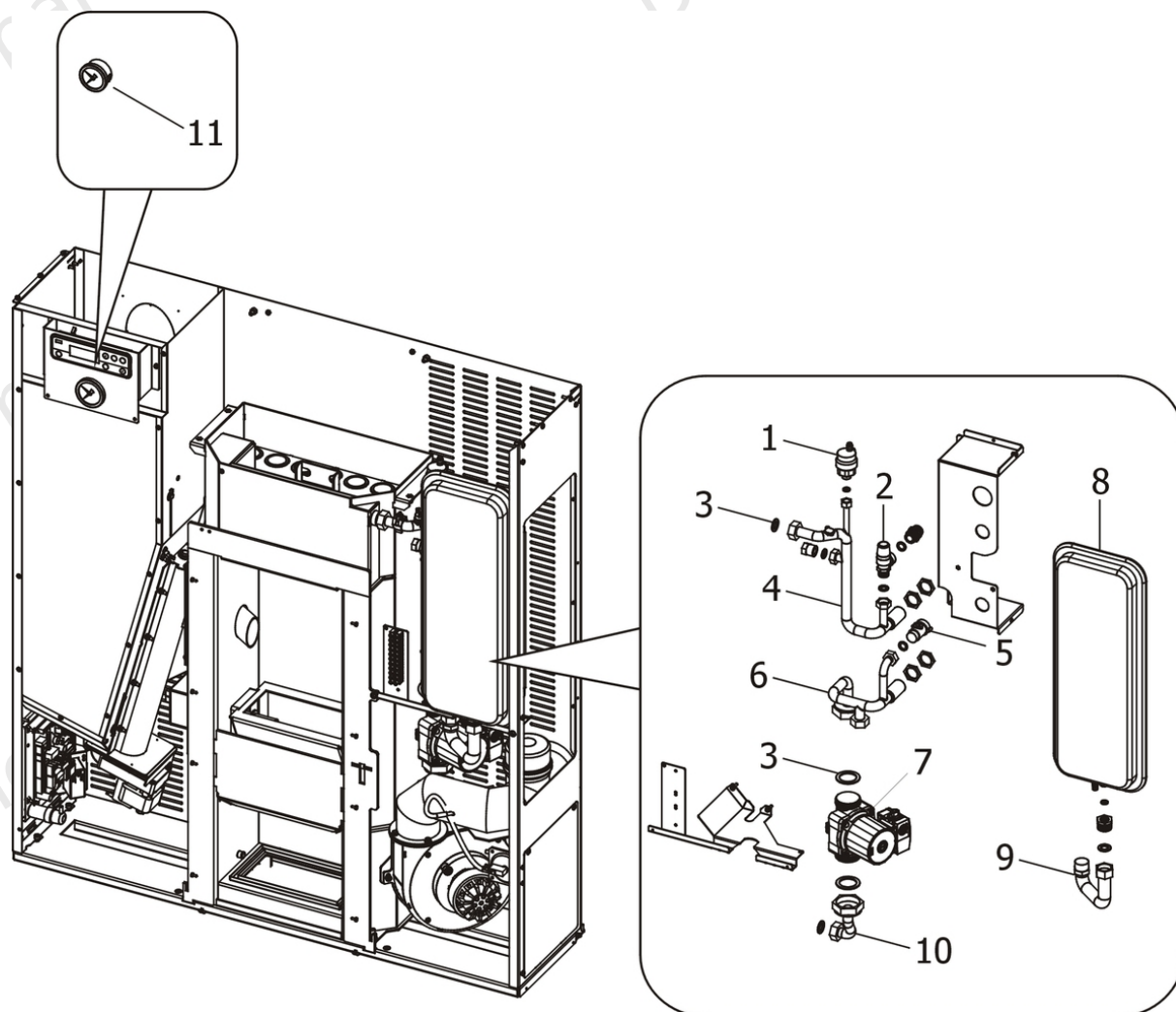

N°	Codice/Code	Descrizioni / Description / Beschreibung / Description / Description
1	4120779	Valvola di sfiato / Vent valve / Entlüftungsventil / Soupape de dégagement / Válvula respiradero
2	4120778	Valvola di massima pressione (3 bar) / Maximum pressure valve (3 bar) / Hochdruckventil (3 Bar) / Soupape de pression maximale (3 bar) / Válvula de máxima presión (3 bar)
3	4120790	Kit guarnizioni impianto idraulico / Hydraulic system gasket kit / Dichtungsbausatz für Hydraulikanlage / Kit de joints pour l'installation hydraulique / Kit de juntas de la instalación de fontanería
3	4120790	Kit guarnizioni impianto idraulico / Hydraulic system gasket kit / Dichtungsbausatz für Hydraulikanlage / Kit de joints pour l'installation hydraulique / Kit de juntas de la instalación de fontanería
4	41501300300	Tubo di mandata impianto / Water delivery tube / Vorlaufrohr Wasser / Tuyau de refoulement eau / Tubo de envío de agua
5	4160351	Rubinetto scarico 1/2" con tappo / 1/2" drain valve with plug / Ablaufhahn 1/2" mit Stopfen / Robinet évacuation 1/2" avec bouchon / Grifo de desagüe 1/2" con tapón
6	41501300400	Tubo di ritorno acqua / Water return tube / Wasserrücklaufrohr / Tuyau retour eau / Tubo de regreso agua
7	41501205200	Pompa di circolazione acqua / Water circulation pump / Umwälzpumpe / Pompe de circulation eau / Bomba circulación agua
7	41501500100	Pompa alta efficienza / High efficiency pump / Hoch effizientz Pumpe / Pompe de circulation haut rendement / Bomba circulación alto rendimiento
8	4120775	Vaso espansione (6 l) / Expansion vessel (6 l) / Expansionsgefäß (6 l) / Vase d'expansion (6 l) / Vaso de expansión (6 l)
9	4120781	Giunto estensibile inox 3/4" / 3/4" stainless steel flexible joint / Edelstahl Verbindungsschlauch 3/4" / Joint flexible inox 3/4"

		/ junta flexible inox ¾"
10	41501300200	Tubo da caldaia a circolatore / Delivery tube from boiler to pump / Vorlaufrohr Wasser vom Kessel zu Pumpe / Tuyau de refoulement eau de la chaudière à la Pompe de circulation / Tubo de envío de agua a la bomba circulación
11	41501100901	Manometro / Manometer / Manometer / Manomètre / Manómetro

COMPACT SLIM 15

Gruppo scambiatore / Exchanger group / Austausch Baugruppe / Groupe échangeur / Grupo intercambiador

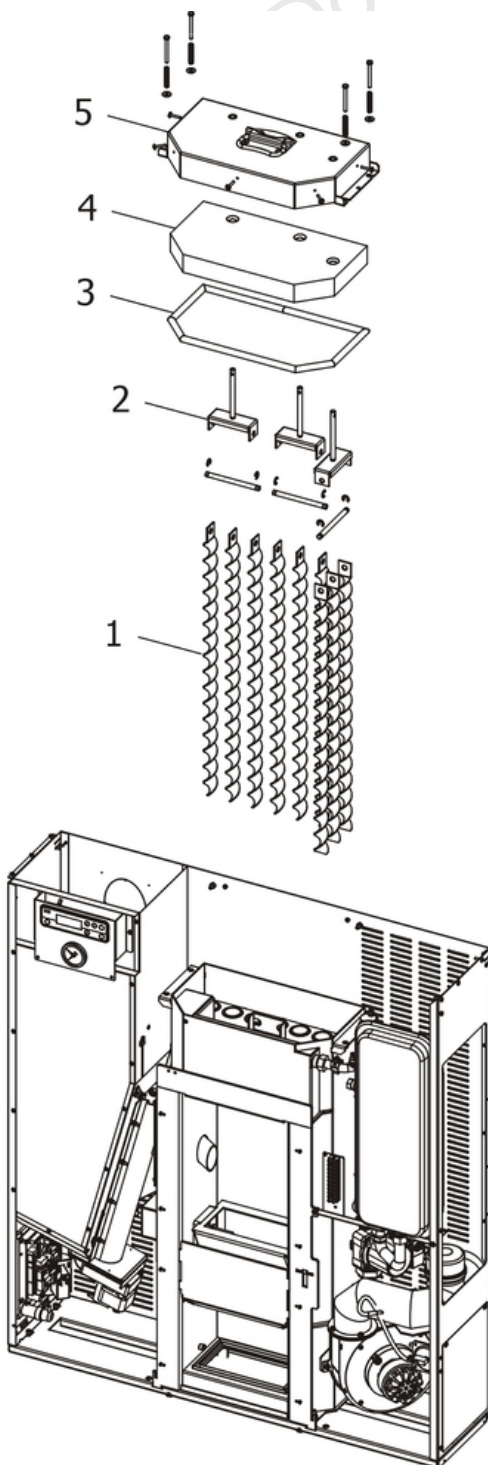

N°	Codice/Code	Descrizioni / Description / Beschreibung / Description / Descripción
1	41401322500	Eliche raschiatore (1 pz.) / Turbulator props (1 pc.) / Propeller des Schabers (1 Teil) / Hélices turbulateur (1 pz.) / Héliche rascador (1 pz.)
2	41401322640	Staffa sostegno raschiatore / Turbulator support bar / Haltebügel der Reinigungsspirale / étrier support turbulateur / Zuncho apoyo rascador

3	412007003A	Cordino fibroceramico Ø 14 mm (5 mt.) / Ceramic fibre cord Ø 14 mm (5 m.) / Keramikfaserschnur Ø 14 mm (5 m) / Cordon en fibre céramique Ø 14 mm (5 m) / Junta a cuerda de fibra cerámica Ø 14 mm (5 m)
3	412007003B	Cordino fibroceramico Ø 14 mm (50 mt.) / Ceramic fibre cord Ø 14 mm (50 m.) / Keramikfaserschnur Ø 14 mm (50 m) / Cordon en fibre céramique Ø 14 mm (50 m) / Junta a cuerda de fibra cerámica Ø 14 mm (50 m)
3	412007003C	Kit sostituzione cordino (cordino+silicone) Ø 14 mm / Cord replacement kit (cord + silicon) Ø14 mm / Schnuraustauschsetz (Schnur +Silikon) Ø 14 mm / Kit remplacement cordon (cordon+silicon) Ø 14 / Kit sustitución junta a cuerda (junta a cuerda+silicón) Ø 14 mm
4	41151300100	Pannello vermiculite coperchio caldaia / Boiler cover vermiculite panel / Kesseldeckepaneel aus Vermiculite / Panneau en vermiculite couvercle chaudière / Panel en vermiculite tapa caldera
5	41401322840V	Coperchio scambiatore / Exchanger cover / Deckel des Austauschers / Couvercle Echangeur / Tapa intercambiador