

## LOGIKA REFILL 25

Componenti caldaia / Components in the boiler side / Bauteilen Kesselcorpus / Composants coté chaudière / Componentos lado de la caldera

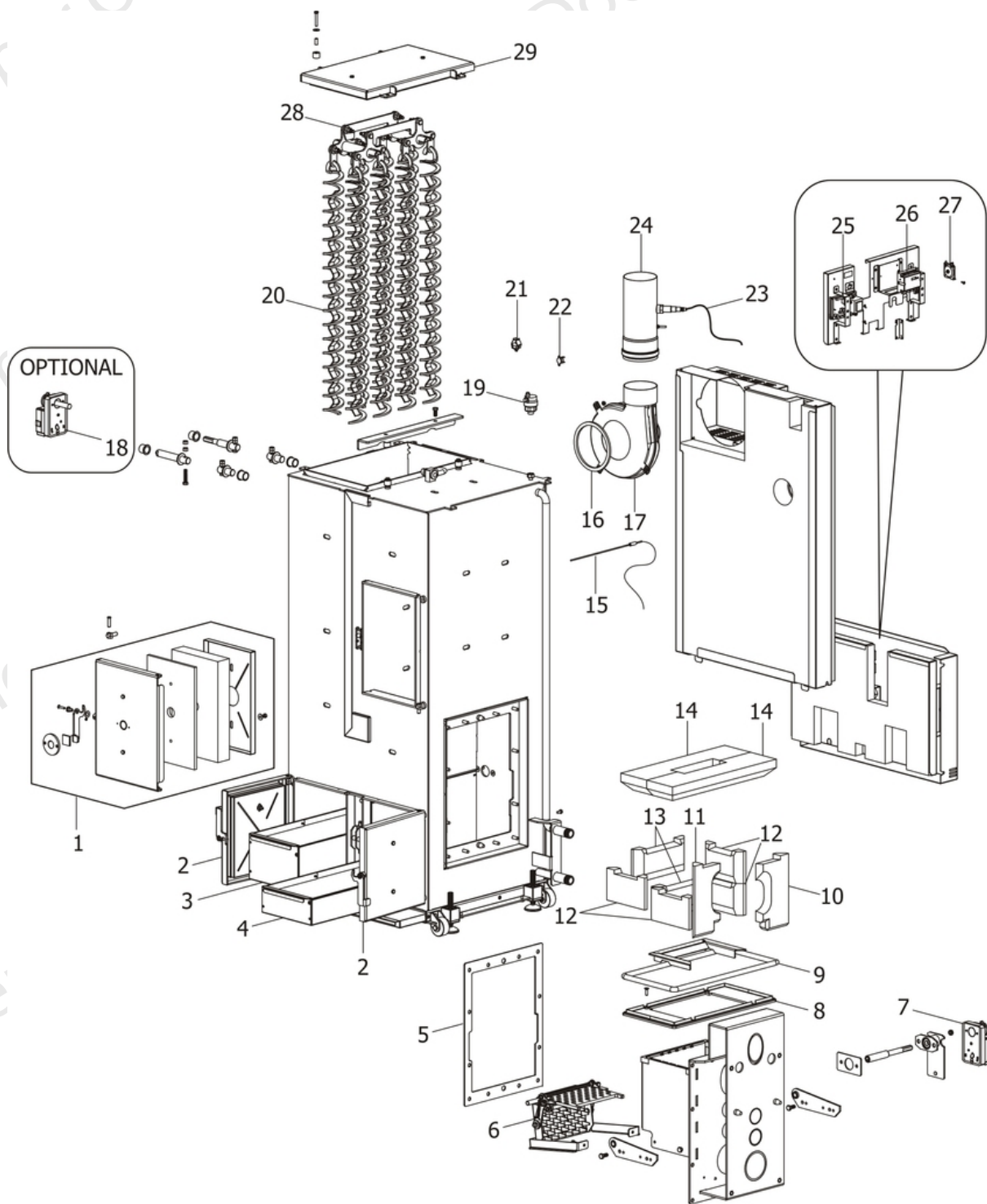

N°	Codice/Code	Descrizioni / Description / Beschreibung / Description / Descripción
1	41401315250	Porta fuoco completa / Complete door / Komplette Feuertür / Porte complète chambre de combustion / Puerta fuego completa
2	41401315150	Porta vano cenere / Ash compartment door / Aschenkasten Tür / Porte tiroir à cendres / Puerta hueco ceniza
3	41411210940	Cassetto cenere piccolo / Little ash drawer / Kleiner Aschenkasten / Tiroir à cendres petit / Cajón ceniza pequeño
4	41411211240	Cassetto cenere grande / Big ash drawer / Großer Aschenkasten / Tiroir à cendres grand / Cajón ceniza grande

5	41801205800	Guarnizione / Gasket / Dichtung / Joint / Junta
6	41411208240	Griglia e raschiatore focolare / Grill and scraper fireplace / Feuerraumgitter und -kratzer / Grille et racleur foyer / Rejilla y raspador hogar
6	41301200460	Griglia rotante / Rotating grille / Drehende Gitter / Grille tournante / Rejilla voltante
7	41451203300	Attuatore / Actuator / Trieb / Actionneur / Actuador
8	41401312560	Tamponazione focolare / Fireplace filling / Feuerraumstopfung / Tampon foyer / Tapa hogar
9	412007003A	Cordino fibroceramico Ø 14 mm (5 mt.) / Ceramic fibre cord Ø 14 mm (5 m.) / Keramikfaserschnur Ø 14 mm (5 m) / Cordon en fibre céramique Ø 14 mm (5 m) / Junta a cuerda de fibra cerámica Ø 14 mm (5 m)
9	412007003B	Cordino fibroceramico Ø 14 mm (50 mt.) / Ceramic fibre cord Ø 14 mm (50 m.) / Keramikfaserschnur Ø 14 mm (50 m) / Cordon en fibre céramique Ø 14 mm (50 m) / Junta a cuerda de fibra cerámica Ø 14 mm (50 m)
9	412007003C	Kit sostituzione cordino (cordino+silicone) Ø 14 mm / Cord replacement kit (cord + silicon) Ø14 mm / Schnuraustauschsatz (Schnur +Silikon) Ø 14 mm / Kit remplacement cordon (cordon+silicon) Ø 14 / Kit sustitución junta a cuerda (junta a cuerda+silicón) Ø 14 mm
10	41151200800	Refrattario sx / L. Refractory / Li. Hitzebeständig / Réfractaire G. / Refrattario IZDO
11	41151200700	Refrattario dx / R. Refractory / Re. Hitzebeständig / Réfractaire D. / Refrattario DCHO
12	41151200900	Refrattario laterale / Lateral refractory / Seitliche Hitzebeständig / Réfractaire latéral / Refrattario lateral
12	41151200900	Refrattario laterale / Lateral refractory / Seitliche Hitzebeständig / Réfractaire latéral / Refrattario lateral
13	41151204100	Parete in refrattario / Refractory wall / Wand aus hitzebeständiges Stoffe / Paroi en réfractaire / Pared en refrattario
14	41151201100	Semitop in refrattario / Refractory semi-top / Halbe-Abdeckung aus hitzebeständiges Stoffe / Demi-dessus en réfractaire / Semi-top en refrattario
15	41451210800	Termocoppia tipo K 3x80 mm 1000°C / Thermocouple type K 3x80 mm 1000°C / Thermoelement Typ K 3x80 mm 1000°C / Thermocouple type K 3x80 mm 1000°C / Termopar modelo K 3x80 mm 1000°C
16	41801100100	Guarnizione adesiva voluta fumi / Adhesive gasket smoke volute / Haftendichtung Rauchvolute / Joint adhesive volute fumées / Junta adhesiva voluta humos
17	41451100300	Ventilatore aspirazione fumi con encoder / Smoke exhausted fan WITH encoder / Rauchabsauggebläse MIT Encoder / Ventilateur aspiration fumées AVEC encoder / Ventilador aspiración humos con codificador
17	41801803900	Guarnizione ø212 / Gasket ø212 / Dichtung ø212 / Joint ø212 / Junta ø212
18	4012015	Kit Easy Clean / Kit Easy Clean / Kit Easy Clean / Kit Easy Clean / Kit Easy Clean
19	4120779	Valvola di sfiato / Vent valve / Entlüftungsventil / Soupape de dégagement / Válvula respiradero
20	41411210640	Turbolatore / Turbulator / Propeller des Schabers / Turbulateur / Rascador
21	41450901200	Sonda temperatura acqua / Water temperature sensor / Wassertemperaturfühler / Sonde température eau / Sonda temperatura agua
22	41450901100	Clickson 95°C / Clickson 95°C / Clickson 95°C / Clickson 95°C / Clickson 95°C
23	41451210900A	Sonda Lambda / Lambda probe / Lambda Sonde / Sonde Lambda / Sonda Lambda
24	41601204040V	Tubo sonda Lambda / Lambda probe pipe / Rohr der Lambda Sonde / Tuyau sonde Lambda / Tubo sonda Lambda
25	41451210900B	Scheda sonda Lambda / Lambda probe motherboard / Lambda Sonde Platine / Carte mère sonde Lambda / Tarjeta madre sonda Lambda
26	41451206001	Scheda madre N024 MICRONOVA / Motherboard N024 MICRONOVA / Hauptplatine N024 MICRONOVA / Carte mère N024 MICRONOVA / Tarjeta madre N024 MICRONOVA
27	414508040	Pressostato 1.2 mbar / Pressure switch 1.2 mbar / Druckwächter 1.2 mbar / Pressostat 1.2 mbar / Presostato 1.2 mbar
28	41411210410	Biella turbolatori (2 pz) / Turbulator connecting rod (2 pcs) / Turbulatorpleuel (2 St.) / Bielle turbulateur (2 pcs) / Biela turbolados (2 pz)
29	41401315050	Coperchio vano turbolatori / Turbulator compartment cover / Deckel Turbulatorsraum / Couvercle compartiment turbulateur / Tapadera hueco turboladores

## LOGIKA REFILL 25

Componenti serbatoio / Components in the tank side / Bauteilenpelletbehälterterkorpus / Composants coté réservoir / Componentes lado del depósito

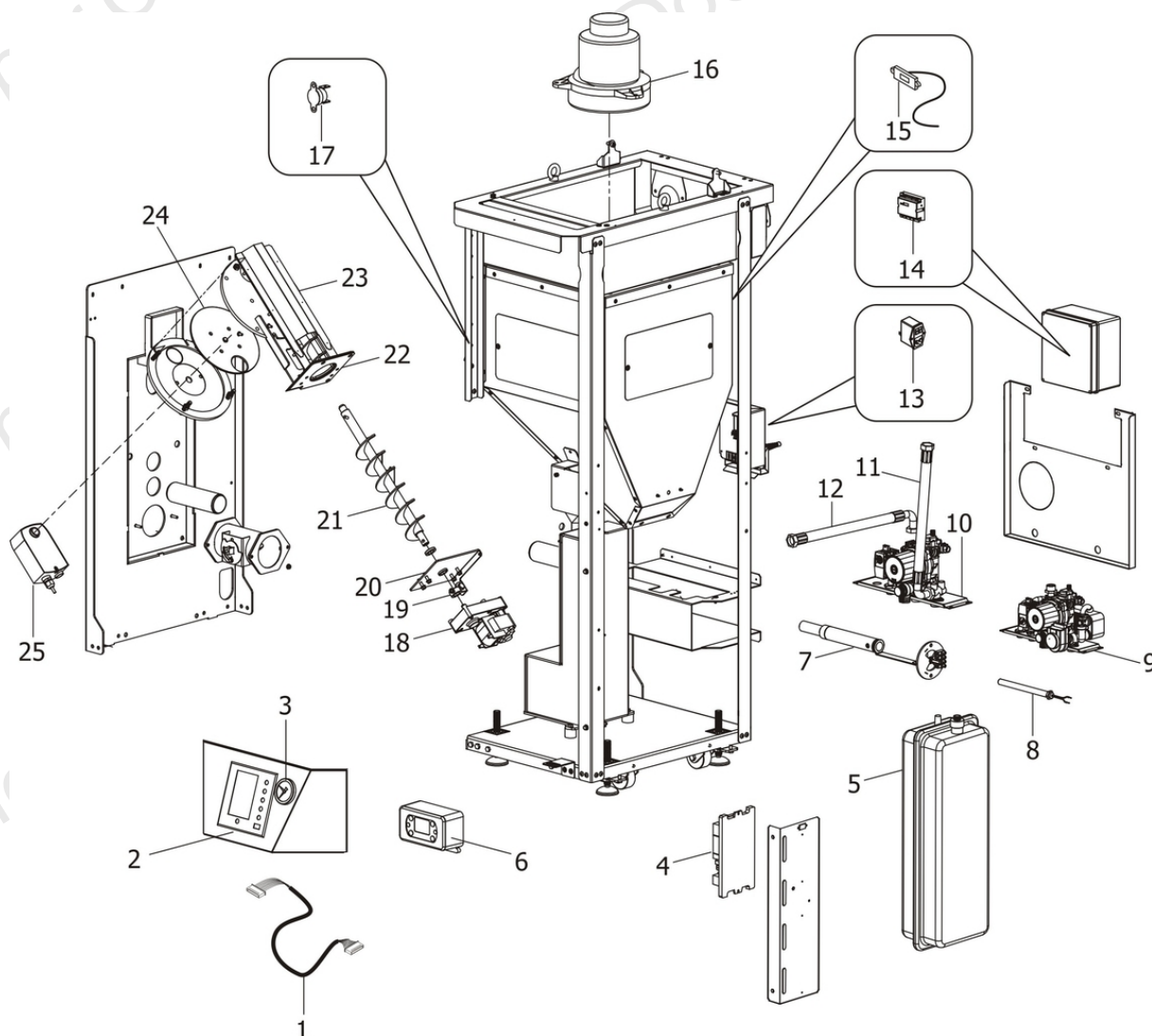

N°	Codice/Code	Descrizioni / Description / Beschreibung / Description / Description
1	41451208100	Cavo display / Display cable / Display Kabel / Câble panneau de commandes / Cable panel de mandos
2	41451206300	Pannello comandi / Control panel / Bedienblende / Panneau de commande / Panel de mandos
3	41501100901	Manometro / Manometer / Manometer / Manomètre / Manómetro
4	41451206200	Scheda madre N025 MICRONOVA / Motherboard N025 MICRONOVA / Hauptplatine N025 MICRONOVA / Carte mère N025 MICRONOVA / Tarjeta madre N025 MICRONOVA
5	41501201900	Vaso espansione 10L / Expansion vessel 10L / Expansionsgefäß 10L / Vase d'expansion 10L / Vaso de expansión 10L
6	41451209800	Centralina / Control panel / Steuereinheit / Panneau de commande / Centralita
7	41401318140	Condotto candeletta / Sparkplug conduit / Zündkerzenkanal / Conduit bougie / Conducto bujía
8	41451304000	Candeletta / Sparkplug / Zündkerze / Bougie / Bujía
9	41501202601	Gruppo idraulico - con produzione acqua sanitaria / Hydraulic unit - with domestic hot water production / Hydraulikeinheit - mit Brauchwarmwasser Herstellung / Unité hydraulique - avec production eau chaude sanitaire / Unidad hidráulica - con producción agua caliente sanitaria
10	40A13022	Kit circolatore / Circulator kit / Umwälzpumpenset / Kit circulateur / Kit bomba
10	40A13023	Kit circolatore alta efficienza / High efficiency circulator kit / Hochleistungs-Umwälzpumpenset / Kit circulateur à haut rendement / Kit bomba de alto rendimiento
11	41501205000	Tubo flessibile 3/42"F-90 L.1100 / Flexible pipe 3/42"F-90 L.1100 / Flexibles Rohr 3/42"F-90 L.1100 / Tuyau flexible 3/42"F-90 L.1100 / Flexible Tube 3/42"F-90 L.1100

12	41501205000	Tubo flessibile 3/42"F-90 L.1100 / Flexible pipe 3/42"F-90 L.1100 / Flexibles Rohr 3/42"F-90 L.1100 / Tuyau flexible 3/42"F-90 L.1100 / Flexible Tube 3/42"F-90 L.1100
13	41451107400	Pulsante accensione / On/Off button / Zündungstaste / Touche d'allumage / Botón encendido
14	41451300300	Scatola cablaggi e comandi aspiratore / Wiring and control box aspirator / Schachtel mit Verkabelung und Steuerung für Sauger / Boîte câblage et commande aspirateur / Caja cableado y mando aspirador
15	41451209500	Sensore livello pellet / Pellet level sensor / Pelletmengenfühler / Capteur niveau des pellets / Sensor de nivel pellet
16	41451203700	Aspiratore / Aspirator / Sauger / Aspirateur / Aspirador
17	412007004	Clickson 110°C / Clickson 110°C / Clickson 110°C / Clickson 110°C / Clickson 110°C
18	41451204900	Motoriduttore 3,3 RPM / Reduction motor 3,3 RPM / Getriebemotor 3,3 RPM / Motorréducteur 3,3 RPM / Motorreductor 3,3 RPM
19	4120398	Connettore motoriduttore-coclea / Reduction motor-feed screw connector / Verbindung Getriebemotor-Schnecke / Connecteur motorréducteur-vis sans fin / Conector motorreductor-cóclea
20	41401362750	Base della coclea / Feed screw base / Untergestell der Förderschnecke / Base de la vis sans fin / Base de la cóclea
21	41401317240	Albero coclea / Feed screw / Förderschnecke / Vis sans fin / Cóclea
22	4120615	Guarnizione base della coclea / Feed screw base gasket / Dichtung Untergestell der Förderschnecke / Joint pour la base de la vis sans fin / Junta base de la cóclea
23	41401317460	Condotto della coclea / Conduit of feed screw / Rohrleitung der Förderschnecke / Conduit de la vis sans fin / Conducto de la cóclea
24	41401317640	Tagliafiamma / Flame trap / Rückschlagsicherung / Brise-flamme / Rompellamas
25	412007004	Clickson 110°C / Clickson 110°C / Clickson 110°C / Clickson 110°C / Clickson 110°C

## LOGIKA REFILL 25

Rivestimento esterno / External panels / Aussereverkleidung / Habillage externe / Paneles externos

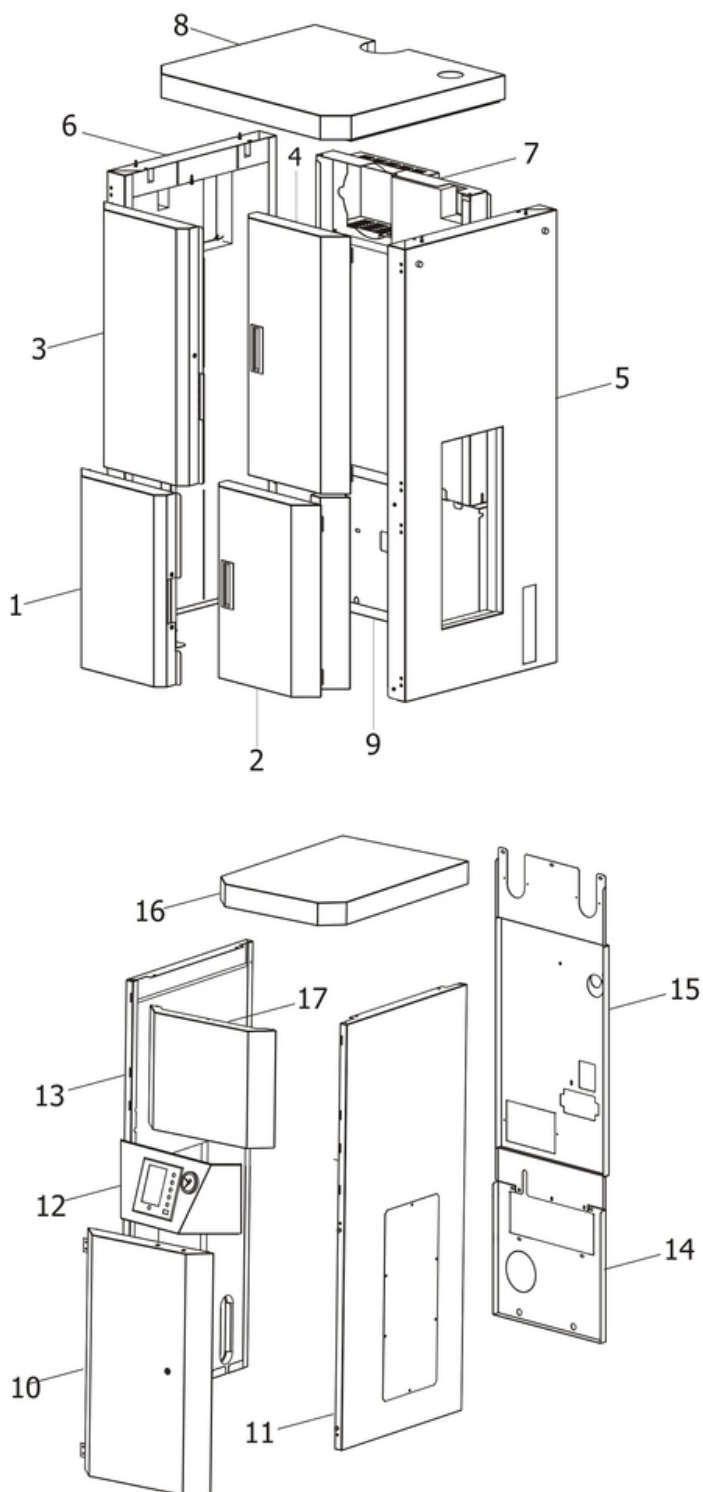

N°	Codice/Code	Descrizioni / Description / Beschreibung / Description / Descripcion
1	41401314250	Porta inferiore SX - Corpo caldaia / Lower L. door - Boiler structure / Untere L. Tür - Kesselkorpus / Porte inférieure G. - Corps chaudière / Puerta inferior IZDA - Cuerpo caldera

<b>2</b>	<b>41401314150</b>	Porta inferiore DX - Corpo caldaia / Lower R. door - Boiler structure / Untere R. Tür - Kesselkorpus / Porte inférieure D. - Corps chaudière / Puerta inferior DCHA - Cuerpo caldera
<b>3</b>	<b>41401314050</b>	Porta superiore SX - Corpo caldaia / Upper L. door - Boiler structure / Obere L. Tür - Kesselkorpus / Porte supérieure G. - Corps chaudière / Puerta superior IZDA - Cuerpo caldera
<b>4</b>	<b>41401313950</b>	Porta superiore DX - Corpo caldaia / Upper R. door - Boiler structure / Obere R. Tür - Kesselkorpus / Porte supérieure D. - Corps chaudière / Puerta superior DCHA - Cuerpo caldera
<b>5</b>	<b>41401313850</b>	Fianco Dx - Corpo caldaia / R. Side - Boiler structure / Re. Seite - Kesselkorpus / Côté D. - Corps chaudière / Lateral DCHO - Cuerpo caldera
<b>6</b>	<b>41401313750</b>	Fianco Sx - Corpo caldaia / L. Side - Boiler structure / Li. Seite - Kesselkorpus / Côté G. - Corps chaudière / Lateral IZDO - Cuerpo caldera
<b>7</b>	<b>41401313650</b>	Schiena superiore - Corpo caldaia / Upper back - Boiler structure / Oberes Rückwand - Kesselkorpus / Fond supérieur - Corps chaudière / Parte trasera superior - Cuerpo caldera
<b>8</b>	<b>41401313550</b>	Coperchio - Corpo caldaia / Cover - Boiler structure / Deckel - Kesselkorpus / Couvercle - Corps chaudière / Tapadera - Cuerpo caldera
<b>9</b>	<b>41411212130</b>	Schiena inferiore - Corpo caldaia / Lower back - Boiler structure / Unteres Rückwand - Kesselkorpus / Fond inférieur - Corps chaudière / Parte trasera inferior - Cuerpo caldera
<b>10</b>	<b>41401314750</b>	Porta inferiore - Lato serbatotio / Lower door - Pellet hopper side / Untere Tür - Pelletbehälterkorpus / Porte inférieure - Côté reservoir / Puerta inferior - Lado depósito
<b>11</b>	<b>41401314450</b>	Fianco Dx - Lato serbatotio / R. Side - Pellet hopper side / Re. Seite - Pelletbehälterkorpus / Côté D. - Côté reservoir / Lateral DCHO - Lado depósito
<b>12</b>	<b>41411231360</b>	Pannello frontale display - Lato serbatotio / Frontal panel display - Pellet hopper side / Vorderes Paneel Bedienblende - Pelletbehälterkorpus / Panneau frontal panneau de commandes - Côté reservoir / Panel frontal panel de mandos - Lado depósito
<b>13</b>	<b>41401314350</b>	Fianco Sx - Lato serbatotio / L. Side - Pellet hopper side / Li. Seite - Pelletbehälterkorpus / Côté G. - Côté reservoir / Lateral IZDO - Lado depósito
<b>14</b>	<b>41411231930</b>	Schiena inferiore - Lato serbatotio / Lower back - Pellet hopper side / Unteres Rückwand - Pelletbehälterkorpus / Fond inférieur - Côté reservoir / Parte trasera inferior - Lado depósito
<b>15</b>	<b>41411231730</b>	Schiena superiore - Lato serbatotio / Upper back - Pellet hopper side / Oberes Rückwand - Pelletbehälterkorpus / Fond supérieur - Côté reservoir / Parte trasera superior - Lado depósito
<b>16</b>	<b>41401314550</b>	Coperchio - Lato serbatotio / Cover - Pellet hopper side / Deckel - Pelletbehälterkorpus / Couvercle - Côté reservoir / Tapadera - Lado depósito
<b>17</b>	<b>41411231260</b>	Pannello frontale - Lato serbatotio / Frontal panel - Pellet hopper side / Vorderes Paneel - Pelletbehälterkorpus / Panneau frontal - Côté reservoir / Panel frontal - Lado depósito

## LOGIKA REFILL 25

Easy clean / Easy clean / Easy clean / Easy clean / Easy clean

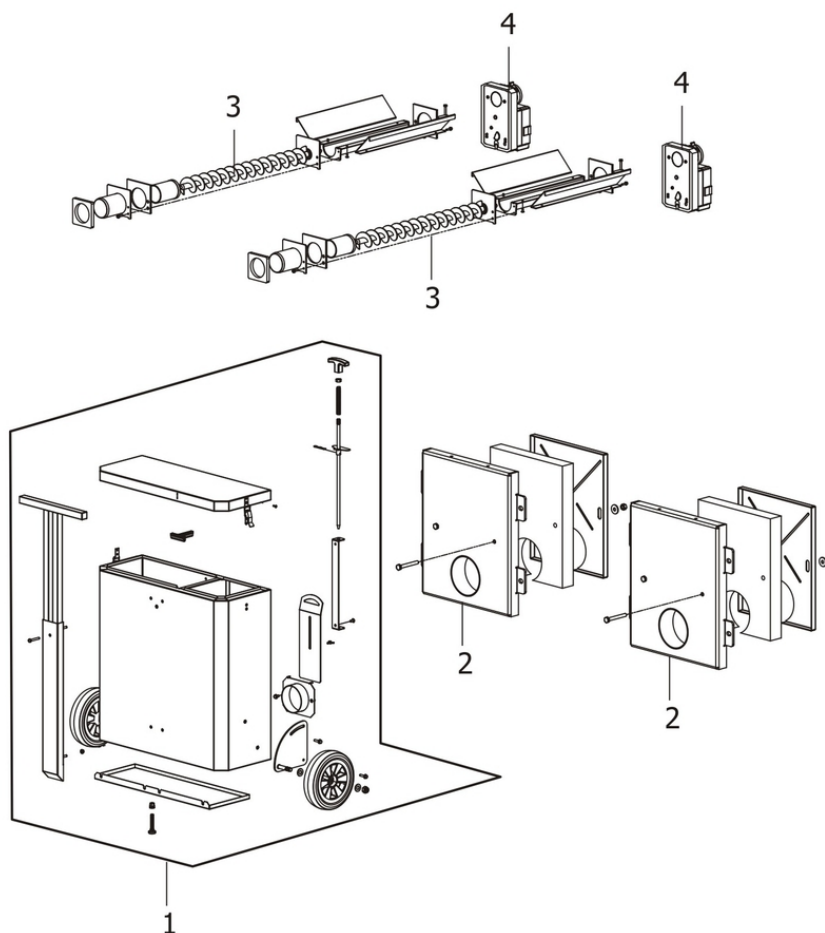

N°	Codice/Code	Descrizioni / Description / Beschreibung / Description / Description
1	41801207550	Trolley completo / Complete trolley / Komplet Trolley / Trolley completo / Trolley completo
1	41801207750	Ruota SX trolley / L.Wheel / Li.Rad / G.Roue / Rueda IZDO
1	41801207850	Ruota DX trolley / R.Wheel / Re.Rad / Roue D. / Rueda DCHO
2	41801207450	Sportello cenere / Ash door / Aschenklappe / Porte cendres / Puertita ceniza
3	41801207350	Gruppo estrazione coclea / Feed screw extraction group / Schneckengruppe zur Aschenentlerung / Groupe extraction vis sans fin / Grupo extracción cóclea
3	41801207350	Gruppo estrazione coclea / Feed screw extraction group / Schneckengruppe zur Aschenentlerung / Groupe extraction vis sans fin / Grupo extracción cóclea
3	41201216000	Boccola coclea cenere / Busch / Buchse / Bride / Brida
4	41450901600	Motoriduttore 3,3 rpm Merkle Korff / Reduction motor 3,3 rpm Merkle Korff / Getriebemotor 3,3 RPM MERKLE KORFF / Motorréducteur 3,3 RPM MERKLE KORFF / Motorreductor 3,3 rpm Merkle Korff