

MCZ GROUP

CLUB COMFORT AIR 14 UP! M2 - CLUB COMFORT AIR 14 UP! M2+

Gruppo estetico / Aesthetic group / Aesthetische Gruppe / Groupe esthétique / Grupo estético

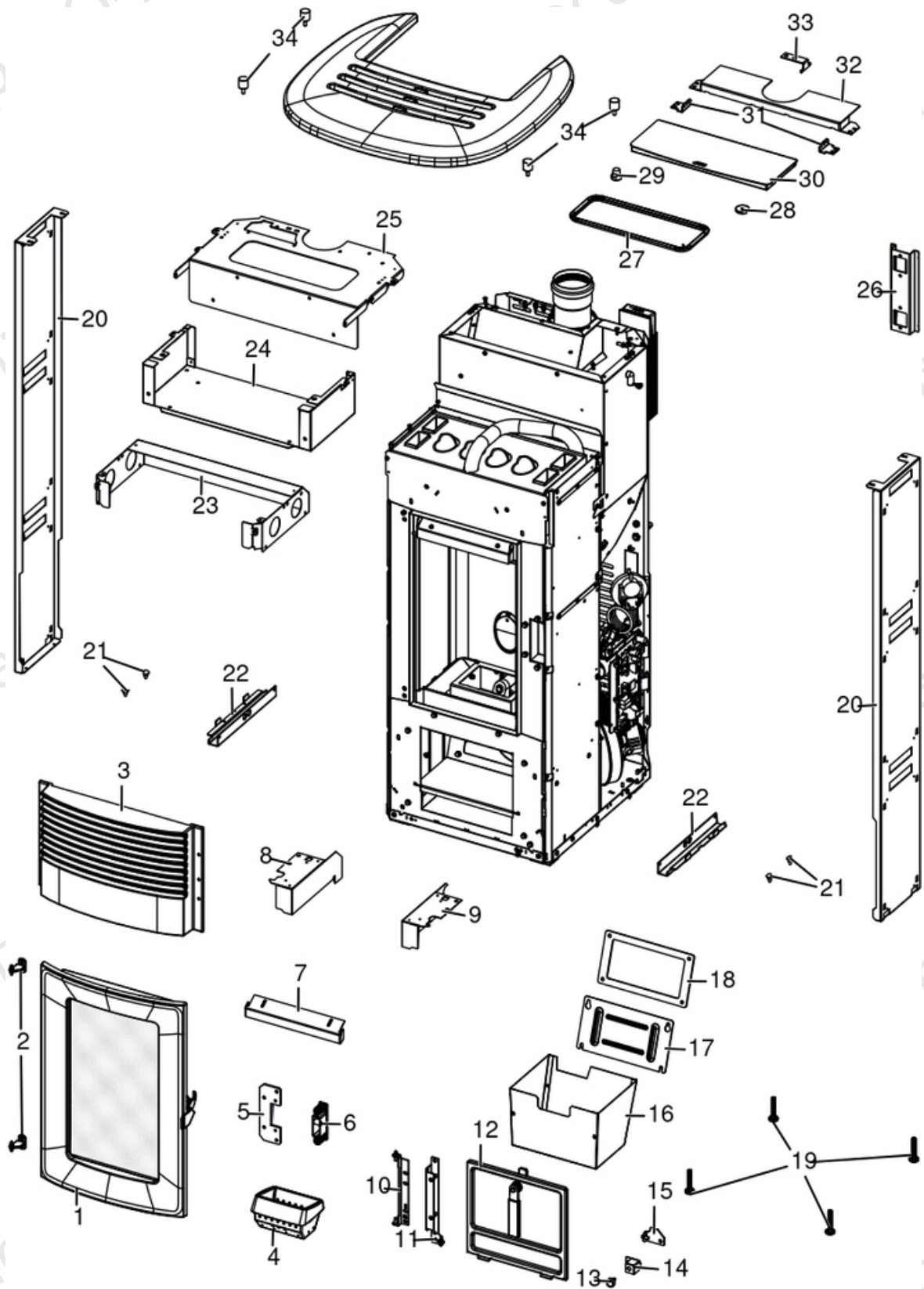

N°	Codice/Code	Descrizioni / Description / Beschreibung / Description / Descripcion
1	41402128050	Porta completa / Complete door / Komplette Tür / Porte complète / Puerta completa
2	41202006990	Cerniera porta / Door hinge / Türscharnier / Charnière de porte / Bisagra de puerta
3	4130200630000	Griglia aria in ghisa / Cast iron air grille / Luftgitter aus Guß / Grille air en fonte / Rejilla aire de arrabio
4	41301502400V	Braciere ghisa / Cast iron grate / Brennertopf aus Gusseisen / Brasero en fonte / Brasero en arrabio
5	41411697710	Flangia serratura / Lock flange / Verschlussflansch / Bride de blocage / Brida de bloqueo
6	41411599950	Kit serratura ammortizzato / Pressur relief kit / Bausatz Überdruckablauf Brennkammer / Kit deocompression chambre comcusion / Kit decompression cámara combustion
7	41411615430V	Deflettore aria / Air deflector / Luftleitblech / Déflecteur aire / Deflector aire
8	41401626131V	Tamponazione sx / L. filling / Abdichtung L. / Tampon G. / Taponado IZDO
9	41401626031V	Tamponazione dx / R. filling / Abdichtung R. / Tampon D. / Taponado DCHO
10	4140212863000	Staffa cerniera / Hinge bracket / Scharniere Haltebügel / Etrier charnière / Soporte bisagra
11	41402126250	Supporto sportello / Door braket / Türträger Klappe / Etrier porte / Soporte puerta
12	437016130	Porta cenere con maniglia / Ash drawer door with handle / Tür des Aschenkastens mit Griff / Porte tiroir à cendres avec poignée / Puerta cajón ceniza con tirador
13	41202007700	Magnete / Magnet / Magnet / Aimant / Imán
14	41402127830	Supporto magnete / Magnet support / Magnet Halterung / Support aimant / Soporte para el imán
15	41411674540V	Supporto sportello cenere / Ash drawer support / Aschenkasten Stütze / Support tiroir à cendres / Soporte Cajón ceniza
16	437016041	Cassetto cenere / Ash drawer / Aschenkasten / Tiroir à cendres / Cajón ceniza
17	41401339610	Tappo ispezione vano fumi / Smoke compartment inspection plug / Inspektionsdeckel Rauchabzug / Clapet inspection compartiment fumées / Tapón inspección compartimento humos
18	41800900600	Guarnizione / Gasket / Dichtung / Joint / Junta
19	41200906660	Piedini di appoggio (4 pz.) / Support feet (4 pcs.) / Einstellfüße (4 Stck.) / Vérins d'appui (4 p.es) / Pies de apoyo (4 piezas)
20	41402128530	Telaio supporto ceramiche / Ceramic support frame / Rahmen Keramikhaltebügel / Cadre support céramique / Armazón soporte cerámica
21	41801002300	Paracolpi in silicone Ø 8/5 (2pz) / Silicone bumpers Ø 8/5 (2pcs) / Schlagschutzgummi Ø 8/5 (2 Stck) / Pièces silicone antichoc Ø 8/5 (2pcs) / Anti-golpes en silicona Ø 8/5 (2pzs)
22	41402127730	Staffa inferiore / Lower bracket / Hunterer Halterung / Support inférieur / Soporte inferior
23	41401721830	Convogliatore / Conveyor / Blech / Convoyeur / Conductor
24	4140212843100	Tetto involucro / Roof covering / Dacheindeckung / Couverture de toit / Cubierta de techo
25	4140213233000	Supporto top posteriore / Rear top support / Hintere Deckelhaltebügel / Support du dessus postérieur / Soporte top posterior
26	41402128231	Staffa pannello comandi / Control panel bracket / Bedienblende- Haltebügel / Etrier du tableau de commandes / Abrazadera de soporte de panel de mandos
27	41802007200	Guarnizione tenuta serbatoio / Pellet hopper gasket / Pelletbehälter Dichtung / Joint réservoir pellet / Junta depósito pellet
28	41801657900	Magneti (pz.2) / Magnet (pcs.2) / Magnet (stk. 2) / Aimant (pcs.2) / Imán (pz.2)
29	4120180	Gommini paracolpi (4 pz) / Rubber bumpers (4 pcs.) / Schlagschutzgummi (4 Stck) / Pièces caoutchouc antichoc (4 pcs) / Cauchitos anti-golpes (4 pz)
30	4140213264000	Coperchio serbatoio / Hopper cover / Deckel Pelletbehälter / Couvercle réservoir / Tapa depósito
31	4140213273000	Cerniera coperchio serbatoio / Hinge hopper cover / Scharniere Deckel Pelletbehälter / Charnière couvercle réservoir / Bisagra tapa depósito
32	4140213283100	Coperchio fisso posteriore / Fix rear cover / Hinterer feste Deckel / Couvercle postérieur fixe / Tapa posterior fija
33	41402129330	Staffa tubo fumi / Smoke pipe suport / Haltebügel Rauchrohr / Support tuyau de fumées / Soporte tubo humos
34	41201105600	Antivibranti (10 pz) / anti-vibration mountings (10 pcs) / Schwingungsdämpfer (10 Stck) / Éléments antivibratoires (10 pcs) / Anti-vibraciones (10 pz)

CLUB COMFORT AIR 14 UP! M2 - CLUB COMFORT AIR 14 UP! M2+

Gruppo camera di combustione / Combustion chamber group / Verbrennungskammer Gruppe / Group de chambre de combustion / Grupo cámara de combustión

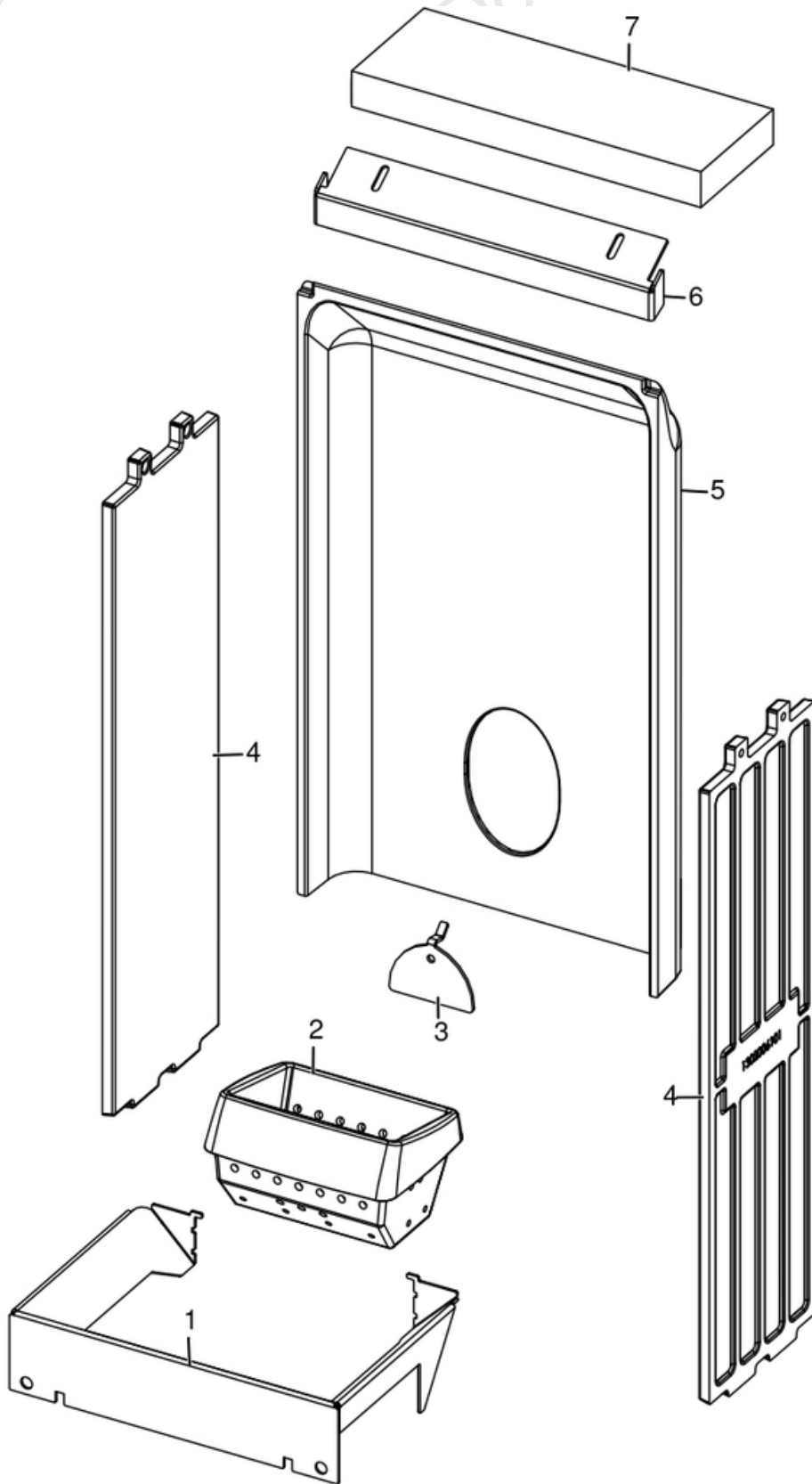

N°	Codice/Code	Descrizioni / Description / Beschreibung / Description / Descripción
1	4140212703100	Protezione cenere / Ashes protection / Aschenschütz / Protection cendres / Protección cenizas
2	41301502400V	Braciare ghisa / Cast iron grate / Brennertopf aus Gusseisen / Brasero en fonte / Brasero en arrabio
3	41411613530V	Deflettore pellet / Pellet deflector / Pellet Leitblech / Deflecteur pellet / Deflector pellet
4	41301502500V	Fianco ghisa / Cast iron side / Seite aus Guß / Côté en fonte / Placa lateral de arrabio
5	41301502600V	Schiena ghisa / Cast iron back / Rückwand aus Gusseisen / Dossieret en fonte / Parte trasera en arrabio
6	41411615430V	Deflettore aria / Air deflector / Luftleitblech / Déflecteur aire / Deflector aire
7	41151600200	Deflettore focolare in vermiculite / Vermiculite deflector / Leitblech aus Vermiculite / Déflecteur en vermiculite / Deflector en vermiculite

CLUB COMFORT AIR 14 UP! M2 - CLUB COMFORT AIR 14 UP! M2+

Rivestimento / Cladding / Verkleidung / Habillage / Revestimiento

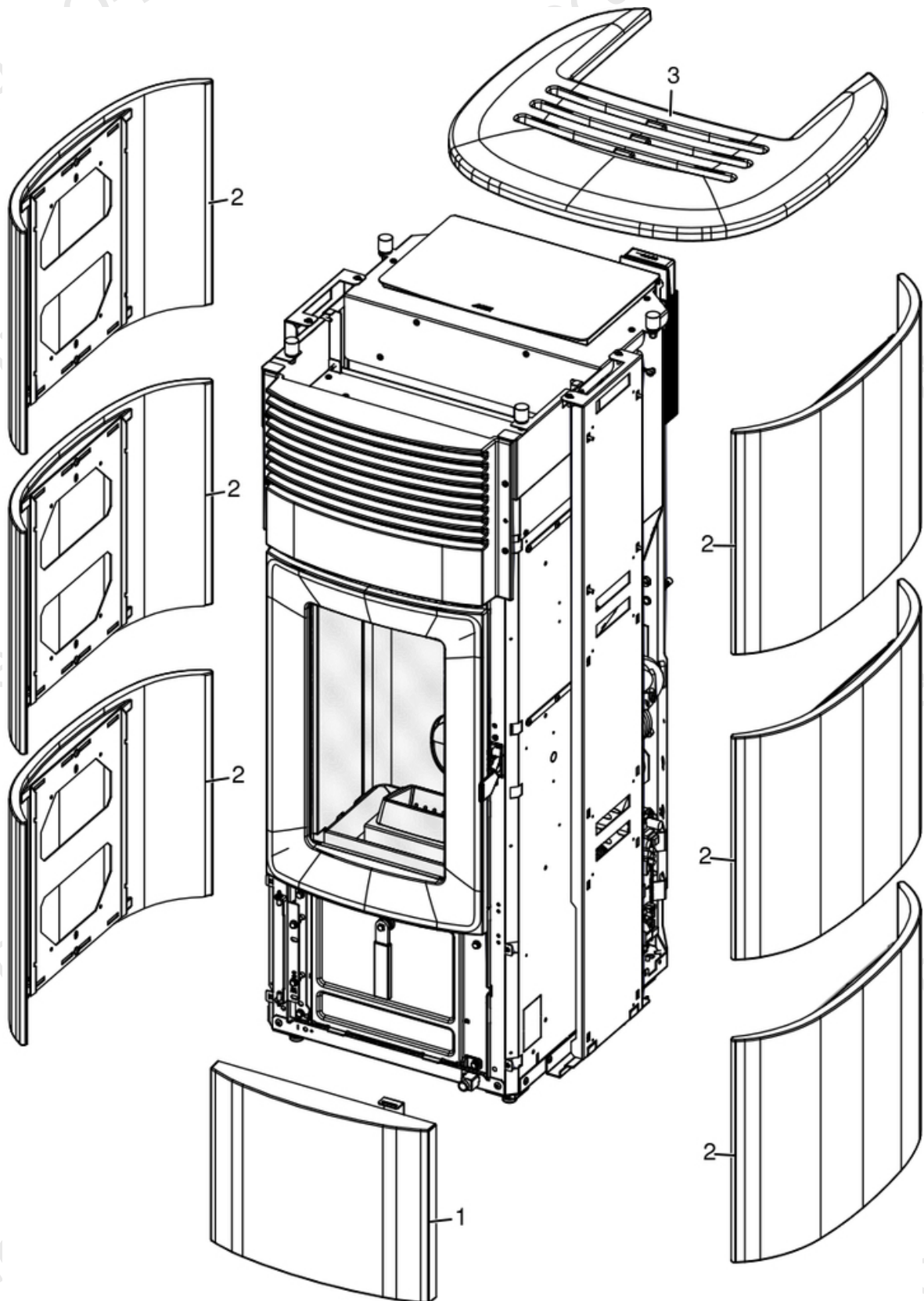

N°	Codice/Code	Descrizioni / Description / Beschreibung / Description / Descripcion
1	4125201045000	Ceramica inferiore bianca / White lower ceramic / Untere Keramik Weiss / Carreaux inférieurs en céramique blanc / Cerámica inferior blanca
1	4125201045001	Ceramica inferiore Bordeaux / Bordeaux lower ceramic / Untere Keramik Bordeaux / Carreaux inférieurs en céramique Bordeaux / Cerámica inferior Bordeaux
1	4125201045002	Ceramica inferiore Nero Matt / Black Matt lower ceramic / Untere Keramik Schwarz Matt / Carreaux inférieurs en céramique Noir Matt / Cerámica inferior Negro Matt
1	4125201045003	Ceramica inferiore Sand / Sand lower ceramic / Untere Keramik Sand / Carreaux inférieurs en céramique Sand / Cerámica inferior Sand
2	4125201025000	Ceramica laterale White / White lateral ceramic / Seitliche Keramik White / Céramique latérale White / Cerámica laterale White
2	4125201025001	Ceramica laterale Bordeaux / Bordeaux lateral ceramic / Seitliche Keramik Bordeaux / Céramique latérale Bordeaux / Cerámica laterale Bordeaux
2	4125201025002	Ceramica laterale Nero Matt / Black Matt lateral ceramic / Seitliche Keramik Schwarz Matt / Céramique latérale Noir Matt / Cerámica laterale Negro Matt
2	4125201025003	Ceramica laterale Sand / Sand lateral ceramic / Seitliche Keramik Sand / Céramique latérale Sand / Cerámica laterale Sand
3	4125200910004	Top ceramica White / Top in ceramic White / Keramik Abdeckplatte Weiss / Dessus en céramique Blanc / Top en cerámica Blanco
3	4125200910001	Top ceramica Bordeaux / Top in ceramic Bordeaux / Keramik Abdeckplatte Bordeaux / Dessus en céramique Bordeaux / Top en cerámica Bordeaux
3	4125200910002	Top ceramica Nero Matt / Top in ceramic Black Matt / Keramik Abdeckplatte Schwarz Matt / Dessus en céramique Noir Matt / Top en cerámica Negro Matt
3	4125200910005	Top ceramica Sand / Top in ceramic Sand / Keramik Abdeckplatte Sand / Dessus en céramique Sand / Top en cerámica Sand

CLUB COMFORT AIR 14 UP! M2 - CLUB COMFORT AIR 14 UP! M2+

Gruppo accensione / Ignition group / Entzündung Gruppe / Groupe d'allumage / Grupo ignición

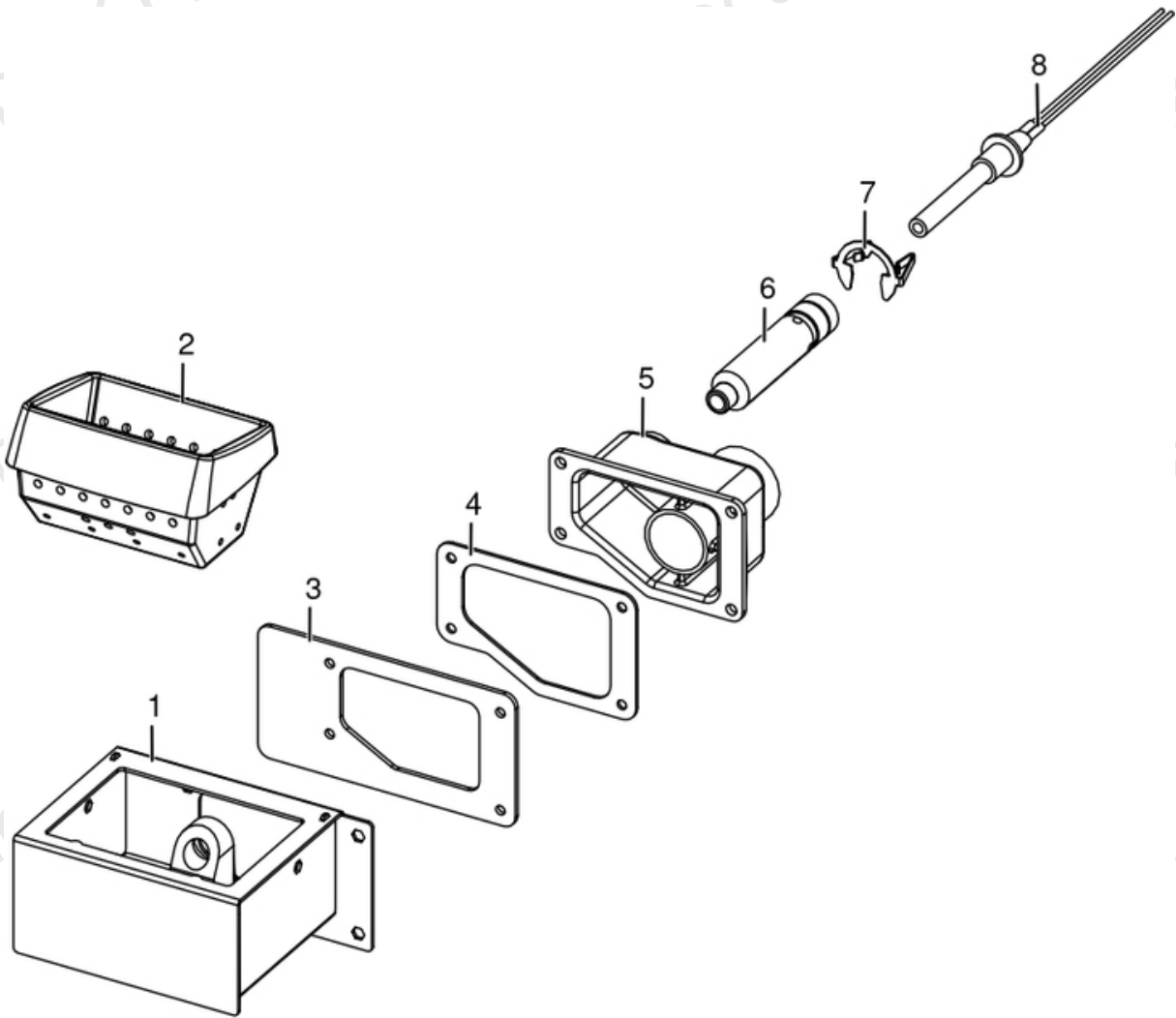

N°	Codice/Code	Descrizioni / Description / Beschreibung / Description / Descripcion
1	41402146940	Tasca braciere / Combustion pot container / Brenntopfkasten / Récipient brasero / Contenedor brasero
2	41301502400V	Braciere ghisa / Cast iron grate / Brennertopf aus Gusseisen / Brasero en fonte / Brasero en arrabio
3	41801601500	Guarnizione tasca braciere / Combustion pot container gasket / Brenntopfkasten Dichtung / Joint récipient brasero / Junta contenedor brasero
4	41801602300	Guarnizione codolo / Gasket / Dichtung / Joint / Junta
5	41311803500	Codolo / Tool chuck / Einspanschaft / Outil d'emmanchement / Mango
6	41601601000	Condotto candelella / Sparkplug Conduit / Zündkerzenkanal / Conduit Bougie / Conducto Bujía
7	41201601500	Anello arresto candelella / Sparkplug stop / Zündkerzestopper / Butée bougie / Tope bujía
8	41451308101	Candelella 315 Watt / Sparkplug 315 Watt / Zündkerze 315 Watt / Bougie 315 Watt / Bujía 315 Watt
8	41451308150	Kit 25 candelette 315 Watt / 25 Sparkplugs 315 Watt kit / Bausatz 25 Zündkerzen 315 Watt / Kit 25 Bougies 315 Watt / Kit 25 Bujías 315 Watt
8	41452009900	Candelella 300 Watt / Sparkplug 300 Watt / Zündkerze 300 Watt / Bougie 300 Watt / Bujía 300 Watt

CLUB COMFORT AIR 14 UP! M2 - CLUB COMFORT AIR 14 UP! M2+

Porta fuoco / Fire door / Feuertür / Porte foyer / Puerta hogar

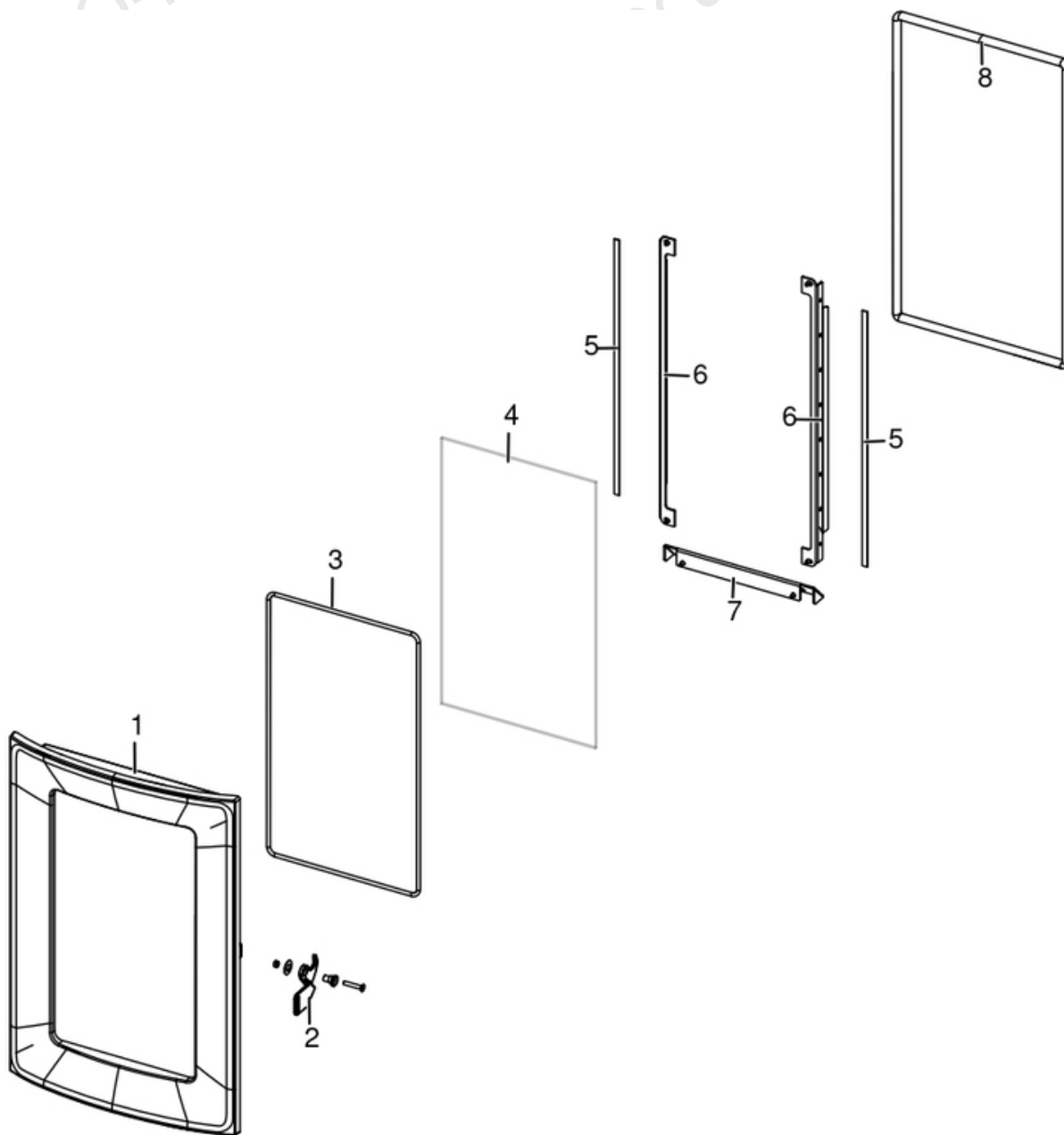

N°	Codice/Code	Descrizioni / Description / Beschreibung / Description / Descripción
1	4130200640000	Porta ghisa / Cast iron door / Tür aus Güsseisen / Porte en fonte / Puerta de arrabio
2	41202007190	Maniglia / Handle / Griff / Poignée / Tirador
3	41801603300A	Guarnizione Ø5 5mt / Gasket Ø5 5mt / Dichtung Ø5 5mt / Joint Ø5 5mt / Junta Ø5 5mt
3	41801603300B	Guarnizione Ø5 50mt / Gasket Ø5 50mt / Dichtung Ø5 50mt / Joint Ø5 50mt / Junta Ø5 50mt
3	41801603300C	Guarnizione Ø5 5mt + silicone / Gasket Ø5 5mt + silic / Dichtung Ø5 5mt + Silikon / Joint Ø5 5mt + silic / Junta Ø5 5mt
4	41701600300	Vetroceramico porta ghisa / Cast iron door glass / Glaskeramikscheibe Tür aus Gusseise / Vitrocéremique porte en fonte / Cristal cerámico puerta en arrabio
5	4120573A	Guarnizione a nastro 8 mm (5 mt.) per porta / Door strip gasket 8 mm (5 m) / Türbanddichtung 8 mm (5 m) / Joint ruban 8 mm (5 m) pour porte / Guarnición de cinta para puerta 8 mm (5 m)
5	4120573B	Guarnizione a nastro 8 mm (50 mt.) per porta / Door strip gasket 8 mm (50 m) / Türbanddichtung 8 mm (50 m) / Joint ruban 8 mm (50 m) pour porte / Guarnición de cinta para puerta 8 mm (50 m)
6	41411622030V	Profilo fermavetro / Fastening bracket profile / Haltebügel für Scheibebefestigung Profil / Profil patte de fixation / Perfil fermacristal
7	41411622130V	Scivolo cenere / Ash ramp / Aschenrutsche / Glissèrie cendre / Tobogán ceniza
8	4120104A	Cordino fibrocaramico Ø 12 mm (5 mt.) / Ceramic fibre cord Ø 12 mm (5 m.) / Keramikfaserschnur Ø 12 mm (5 m) / Cordon en fibre céramique Ø 12 mm (5 m) / Junta a cuerda de fibra cerámica Ø 12 mm (5 m)
8	4120104B	Cordino fibrocaramico Ø 12 mm (50 mt.) / Ceramic fibre cord Ø 12 mm (50 m.) / Keramikfaserschnur Ø 12 mm (50 m) / Cordon en fibre céramique Ø 12 mm (50 m) / Junta a cuerda de fibra cerámica Ø 10 mm (52 m)

CLUB COMFORT AIR 14 UP! M2 - CLUB COMFORT AIR 14 UP! M2+

Porta cenere / Ash door / Ashentür / Porte cendre / Puerta ceniza

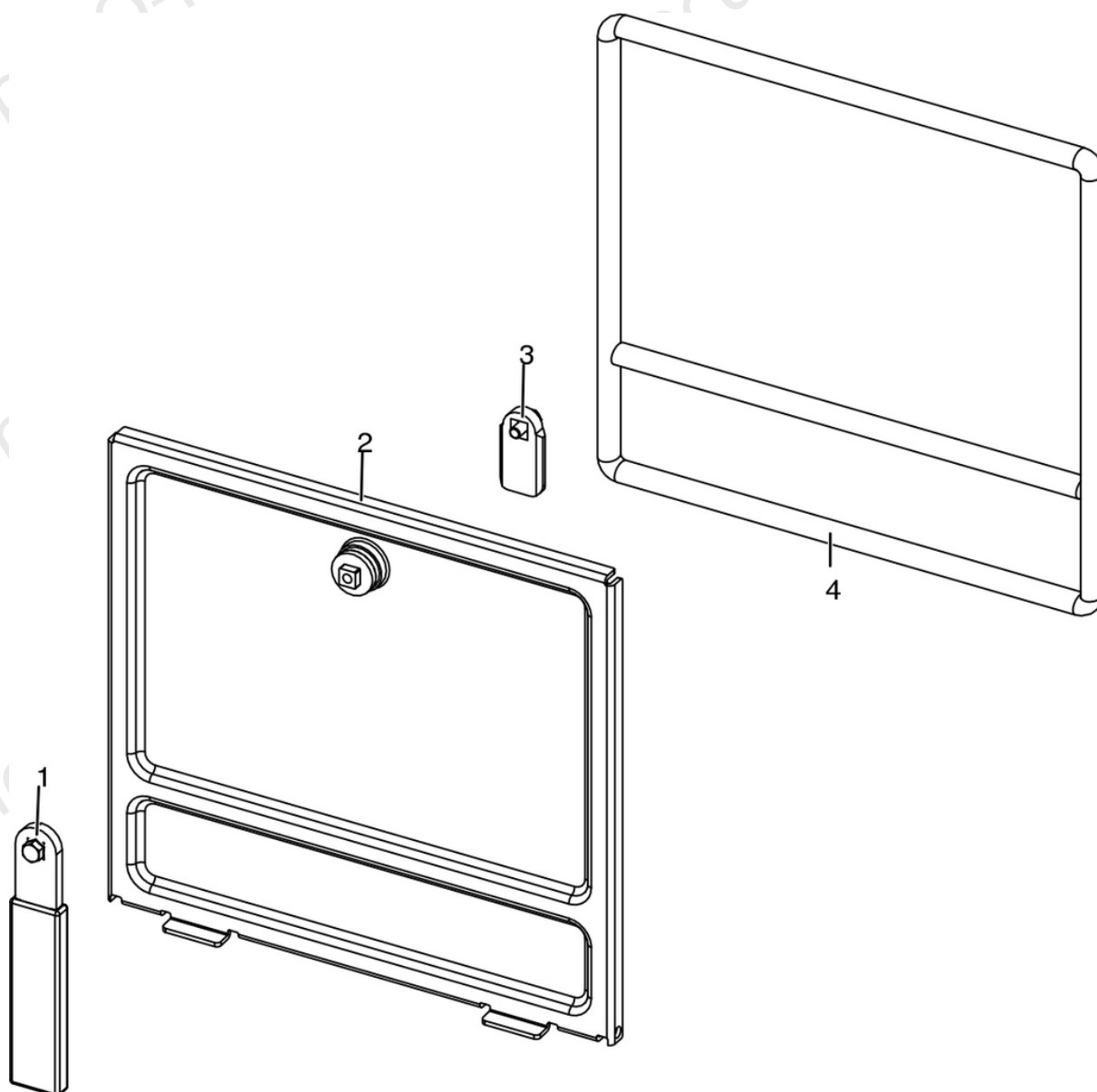

N°	Codice/Code	Descrizioni / Description / Beschreibung / Description / Description
1	41411621600	Maniglia con impugnatura porta cenere / Handle / Griff / Poignée / Tirador
2	41421602141V	Porta cenere / Ash drawer door / Tür des Aschenkastens / Porte tiroir à cendres / Puerta cajón ceniza
3	41201608400	Serratura porta cassetto cenere / Door lock for ash drawer / Türschloss für Aschenkasten / Serrure de porte du tiroir à cendres / Cerradura puerta cajón ceniza
4	412007003A	Cordino fibroceramico Ø 14 mm (5 mt.) / Ceramic fibre cord Ø 14 mm (5 m.) / Keramikfaserschnur Ø 14 mm (5 m) / Cordon en fibre céramique Ø 14 mm (5 m) / Junta a cuerda de fibra cerámica Ø 14 mm (5 m)
4	412007003B	Cordino fibroceramico Ø 14 mm (50 mt.) / Ceramic fibre cord Ø 14 mm (50 m.) / Keramikfaserschnur Ø 14 mm (50 m) / Cordon en fibre céramique Ø 14 mm (50 m) / Junta a cuerda de fibra cerámica Ø 14 mm (50 m)
4	412007003C	Kit sostituzione cordino (cordino+silicone) Ø 14 mm / Cord replacement kit (cord + silicon) Ø14 mm / Schnuraustauschsatz (Schnur +Silikon) Ø 14 mm / Kit remplacement cordon (cordon+silicon) Ø 14 / Kit sustitución junta a cuerda (junta a cuerda+silicón) Ø 14 mm

CLUB COMFORT AIR 14 UP! M2 - CLUB COMFORT AIR 14 UP! M2+

Gruppo caricamento pellet / Pellet feed group / Pellet Fördergruppe / Groupe chargement du pellet / Grupo de carga pellet

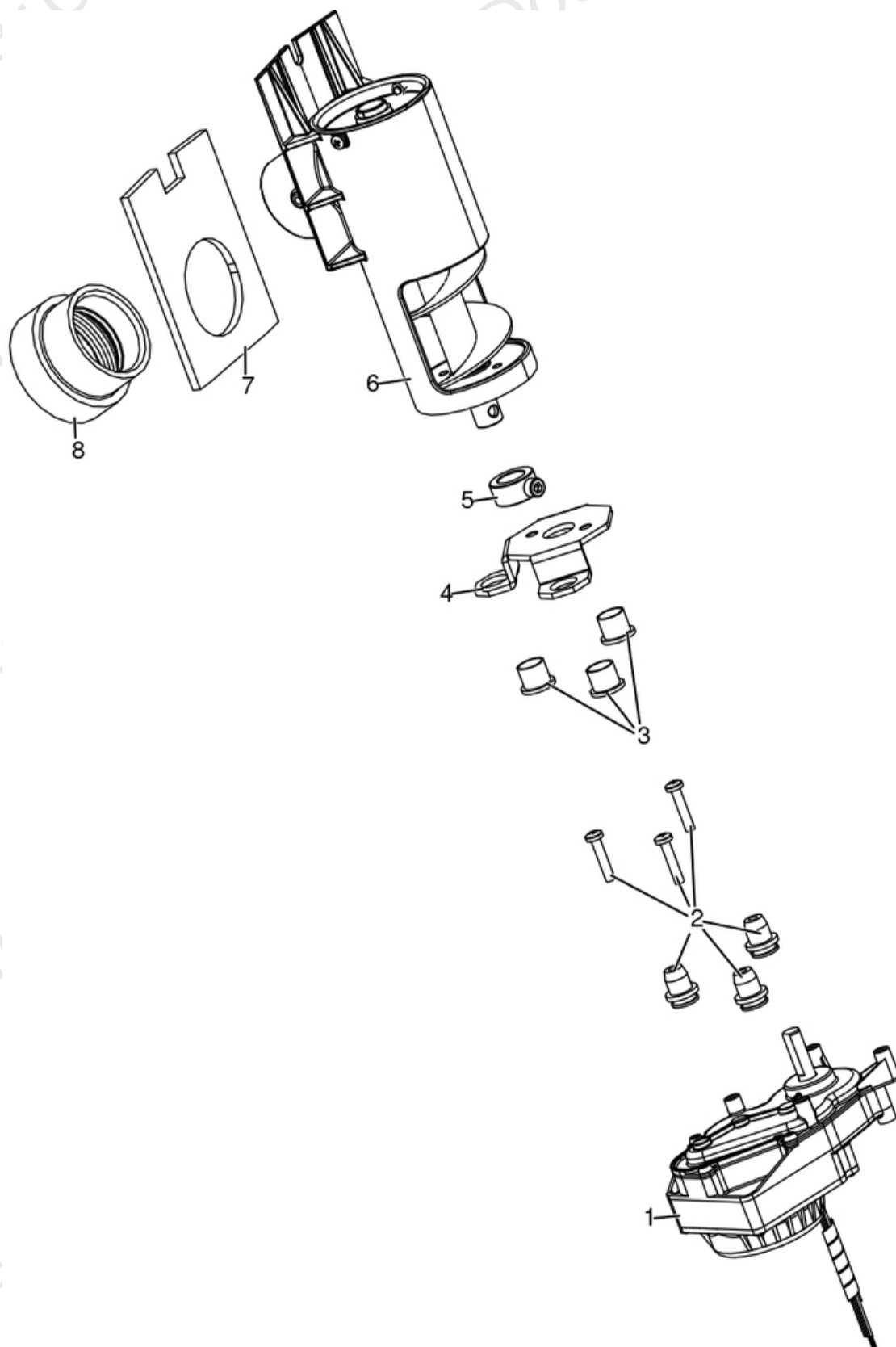

N°	Codice/Code	Descrizioni / Description / Beschreibung / Description / Descripcion
1	41451702200	Motoriduttore brushless / Brushless reduction motor / Brushless Getriebemotor / Motoréducteur brushless / Motorreductor brushless
1	41452000500	Cavo motoriduttore / Reduction motor cable / Kabel Getriebemotor / Câble motoréducteur / Cable motorreductor
2	41801703700	Gommini antivibrante / Vibration damper rubber / Rammenschutz Gummi / Caoutchouc antivibratoire / Cauchitos antivibración
3	41201800700	Boccola (3 pz) / Bushing (3 pcs) / Buchse (3 Stk) / Douille (3 pcs) / Abrazadera (3 pzs)
4	41411779331	Supporto coclea "Ragno" / Pellet feed screw bracket "spider" / "Spinne" Schenke Gestell / Support vis sans fin "Araignée" / Soporte coclea "Araña"
5	4120398	Connettore motoriduttore-coclea / Reduction motor-feed screw connector / Verbindung Getriebemotor-Schnecke / Connecteur motoréducteur-vis sans fin / Conector motorreductor-cóclea
6	41402143150	Gruppo alimentazione / Complete feed screw / Komplette Förderschnecke / Vis sans fin complète / Cóclea de carga completa
7	41802000300	Guarnizione / Gasket / Dichtung / Joint / Junta
8	41801702600	Guarnizione / Gasket / Dichtung / Joint / Junta

CLUB COMFORT AIR 14 UP! M2 - CLUB COMFORT AIR 14 UP! M2+

Gruppo elettrico ed elettronico / Electrical and electronic group / Elektrische und elektronische Gruppe /
Groupe électrique et électronique / Grupo eléctrico y electrónico

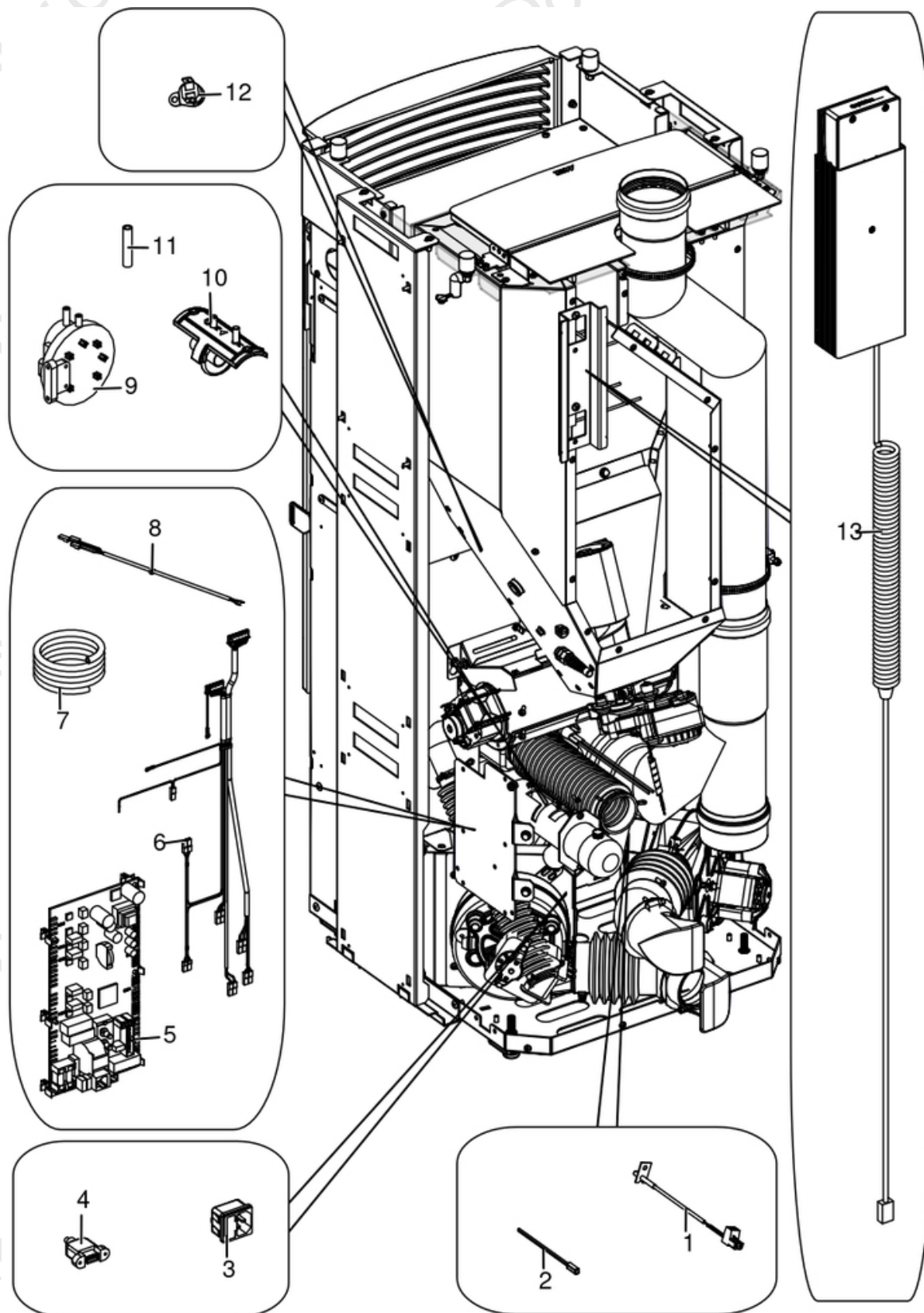

N°	Codice/Code	Descrizioni / Description / Beschreibung / Description / Descripción
1	41451703600	Sonda fumi con flangia con morsettiera L.980 / Smoke sensor with flange with terminal board L.980 / Rauchsonde mit Flansche mit Klemmenbrett L.980 / Sonde fumées avec bride avec serre-câble L.980 / Sonda humos con brida con borne L.980
2	4160386	Sonda temperatura ambiente/acqua / Room/Water temperature sensor / Raum- Wassertemperaturfühler / Sonde température ambiance/eau / Sonda temperatura ambiente/agua
3	41451104100	Presca con fusibile / Socket with fuse / Steckdose mit Sicherung / Prise avec fusible / Toma con fusible
4	41451403200	Cavo USB da pannello L.500 / USB Cable from display L.500 / USB Kabel von Notfalldisplay L.500 / Câble USB de panneau L.500 / Cable USB del panel L.500
5	1010	Non disponibile / Not available / Nicht verfügbar / Non disponibile / No disponible
6	41452008201	Cablaggio / Wiring / Verkabelung / Câblage / Cableado
7	41801902500	Spirale Rilsan (30 m.) / Rilsan spiral (30 m.) / Spirale Rilsan (30 M.) / Spirale Rilsan (30 m.) / Espiral Rilsan (30 m.)
7	41801902500A	Spirale Rilsan (5 spire) / Rilsan spiral (5 coils) / Spirale Rilsan (5 Windungen) / Spirale Rilsan (5 spires) / Espiral Rilsan (5 espire)
8	41452009300	Cablaggio terzo ventilatore / Wiring third fan / Verkabelung dritte Gebläse / Câblage troixième ventilateur / Cableado tercero ventilador
9	41451003700	Pressostato / Pressure switch / Druckschalter / Pressostat / Presostato
10	41601301851	Componente rilevamento portata aria / Air flow measure component / Bauteil für Messung der Luftmenge / Composent pour la mesuration de la quantité d'air / Componente por la medida de l'aire
11	4120631A	Tubicino silicónico - 5m / Silicon tube - 5m / Silikonrohr - 5m / Petit tuyau en silicone - 5m / Tubo silicónico - 5m
12	412007004	Clickson 110°C / Clickson 110°C / Clickson 110°C / Clickson 110°C / Clickson 110°C
13	1010	Non disponibile / Not available / Nicht verfügbar / Non disponibile / No disponible

CLUB COMFORT AIR 14 UP! M2 - CLUB COMFORT AIR 14 UP! M2+

Gruppo ventilazione / Ventilation group / Lüftungsgruppe / Groupe de ventilation / Grupo de ventilación

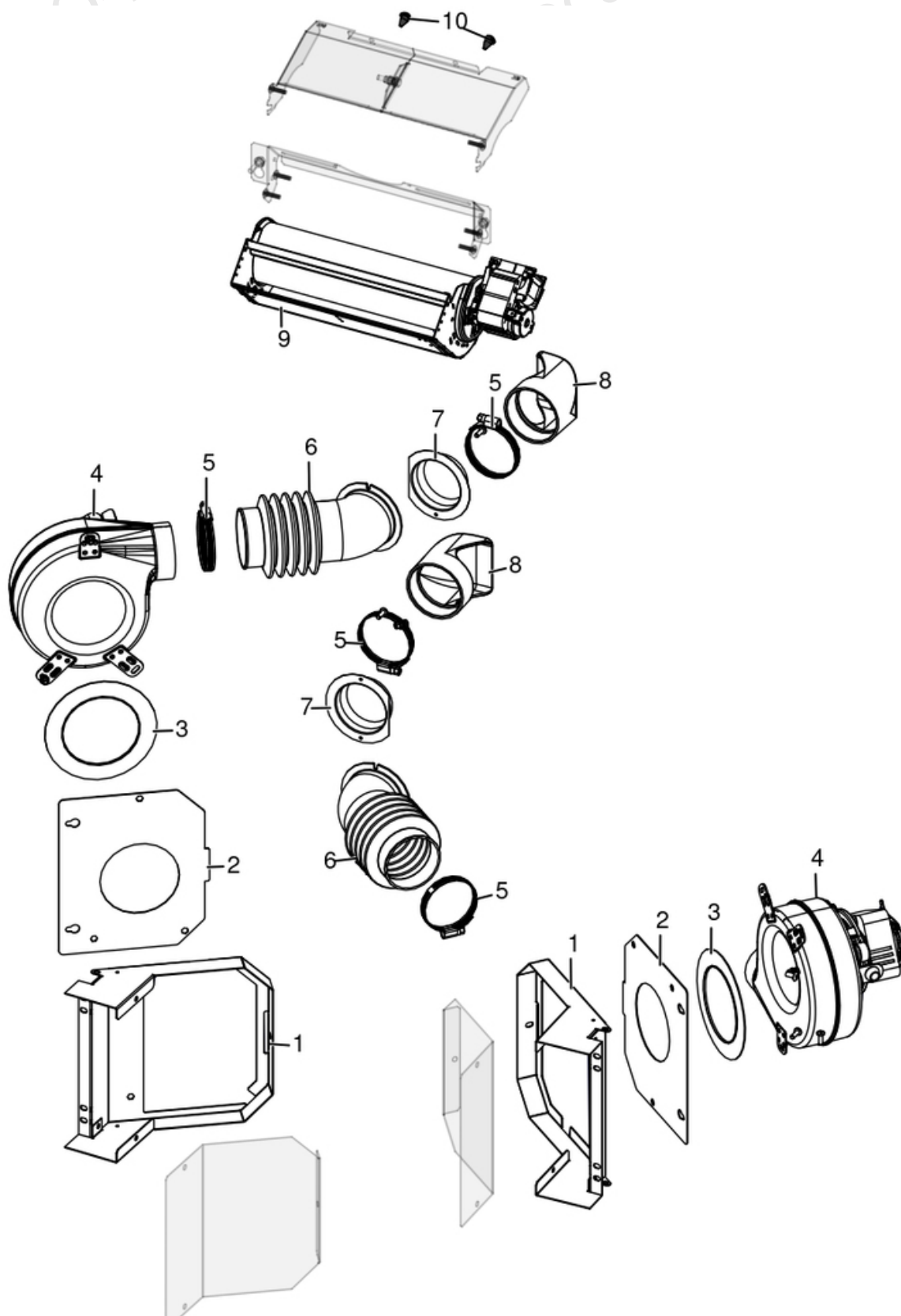

N°	Codice/Code	Descrizioni / Description / Beschreibung / Description / Descripcion
1	41402158830	Convogliatore C/Air / Conveyor C/Air / Blech C/Air / Convoyeur C/Air / Conductor C/Air
2	41402159010	Supporto convogliatore C/Air / C/Air Conveyor support / Halterung Blech C/Air / Support convoyeur C/Air / Soporte conductor C/Air
3	41801601600	Guarnizione ventilatore / Fan gasket / Dichtung des Gebläses / Joint du ventilateur / Junta ventilador
4	41451503300	Ventilatore centrifugo / Air fun / Lufgebläse / Ventilateur air / Ventilador aire
5	41200902000	Fascette Ø 64-76 mm (2 pz) / Clamps Ø 64-76 mm (2 pcs) / Rohrschellen Ø 64-76 mm (2 Stck) / Colliers Ø 64-76 mm (2 pcs) / Bandas Ø 64-76 mm (2 pzs)
6	41801601100	Tubo uscita aria silicone / Outlet air tube in silicone / Luftausgangrohr aus Silikon / Tuyau de sortie air en silicone / Tubo de salida aire en silicona
7	4011011	Flangia Ø 6 / Flange Ø 6 / Flansch Ø 6 / Bride Ø 6 / Brida Ø 6
8	41801605300	Bocchetta posteriore in silicone / Silicone rear air outlet / Luftauslass aus Silikon / Diffuseur air en silicone / Boquilla aire en silicona
9	41451600800	Ventilatore aria / Air fan / Luftgebläse / Ventilateur air / Ventilador aire
10	41801002300	Paracolpi in silicone Ø 8/5 (2pz) / Silicone bumpers Ø 8/5 (2pcs) / Schlagschutzgummi Ø 8/5 (2 Stck) / Pièces silicone antichoc Ø 8/5 (2pcs) / Anti-golpes en silicona Ø 8/5 (2pzs)

CLUB COMFORT AIR 14 UP! M2 - CLUB COMFORT AIR 14 UP! M2+

Gruppo fumi / Smoke group / Rauchgruppe / Groupe fumées / Grupo de humos

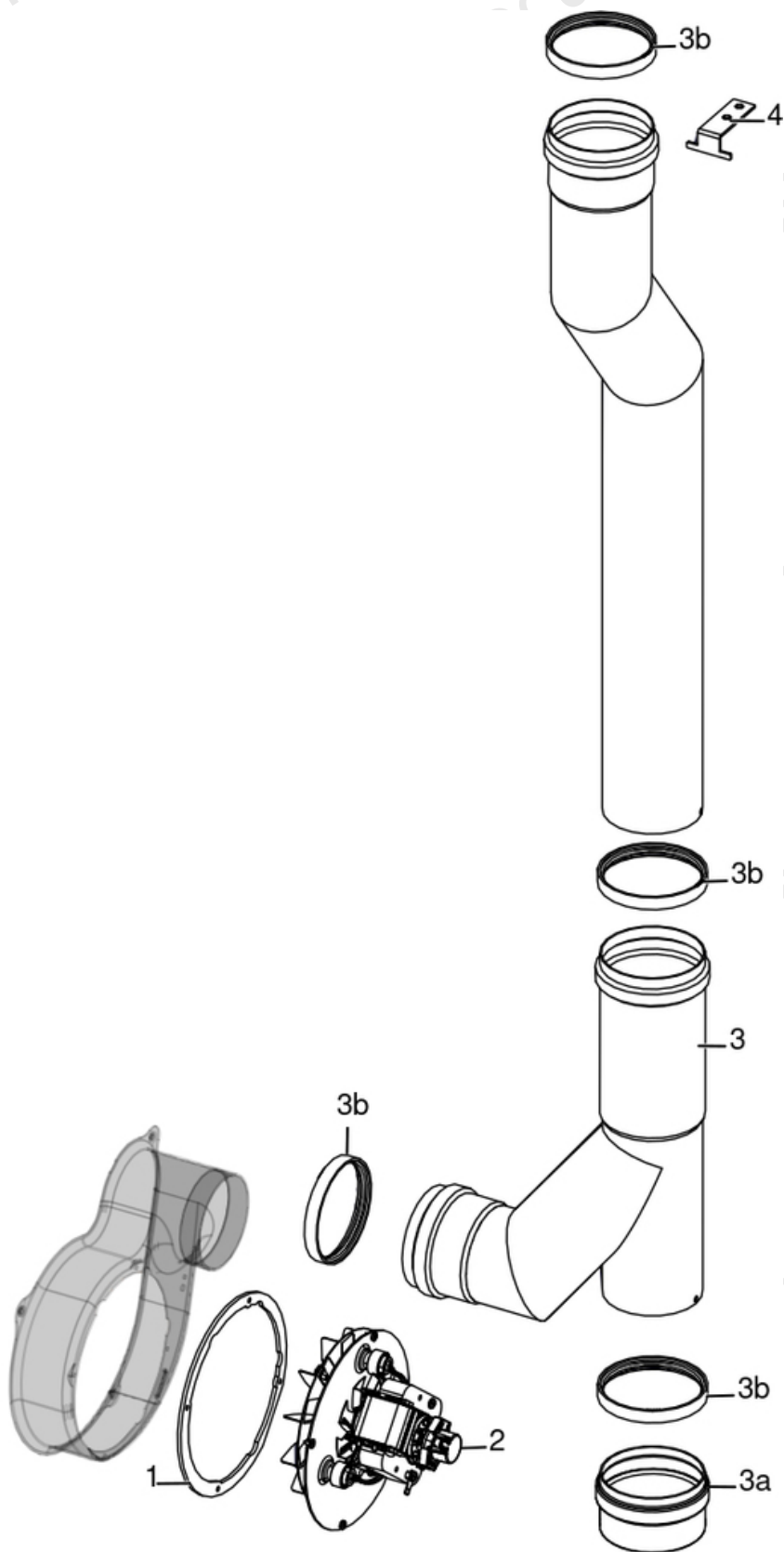

N°	Codice/Code	Descrizioni / Description / Beschreibung / Description / Descripcion
1	41801600800	Guarnizione ventilatore fumi / Smoke exhaust fan gasket / Dichtung Rauchabsauggebläse / Joint Ventilateur aspiration fumées / Junta ventilador aspiración humos
2	41451503200	Ventilatore fumi stagno / Air-tight smoke fan / Luftdichtes Rauchgasgebläse / Ventilateur fumées étanche / Ventilador humos hermético
3	41601605301	Tubo fumi Ø 80 UP / Smoke pipe Ø 80 UP / Rauchrohr Ø 80 UP / Tuyau fumées Ø 80 UP / Tubo humos Ø 80 UP
3a	4016046200	Tappo raccordo T Ø 80 / Plug T connection Ø 80 / Verchluss T Verbindung Ø 80 / Clapé raccord en T Ø 80 / Tapón raccord T Ø 80
3b	40120969	Guarnizione silicone (5pz) / Silicone Gasket (5pc.) / Silikondichtung (5 St.) / Joint en silicone / Junta en silicona
4	41402129330	Staffa tubo fumi / Smoke pipe suport / Haltbügel Rauchrohr / Support tuyau de fumées / Soporte tubo humos