

MCZ GROUP

FLOW COMFORT AIR 10 M1

Gruppo estetico / Aesthetic group / Aesthetische Gruppe / Groupe esthétique / Grupo estético

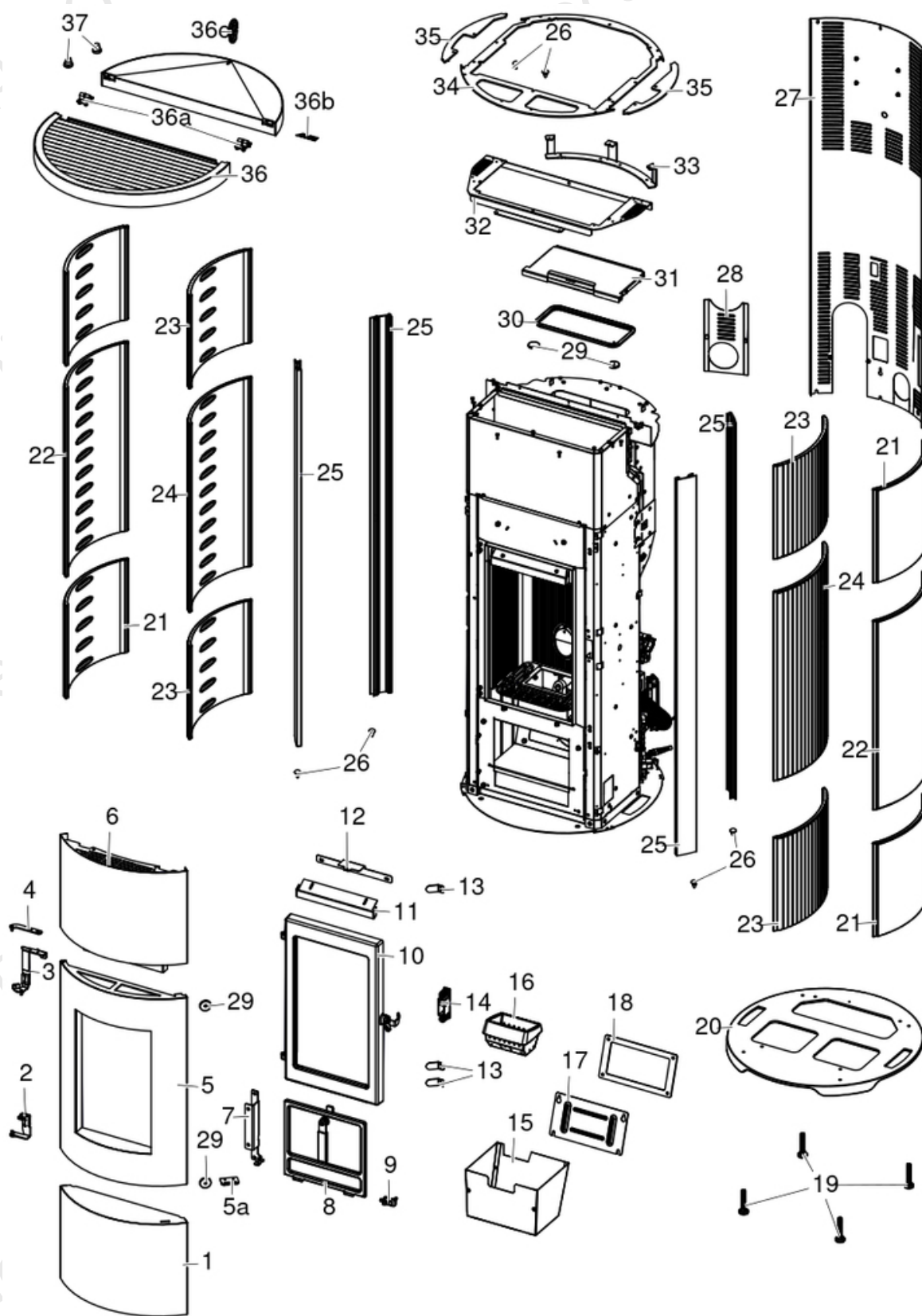

N°	Codice/Code	Descrizioni / Description / Beschreibung / Description / Descripcion
1	41402030350	Pannello inferiore completo / Complete lower panel / Komplettes untere Paneel / Panneau inférieur complet / Panel inferior completo
2	4140202734000	Cerniera inferiore porta estetica / Bottom hinge for aesthetics door / Untere Scharnier für ästhetische Tür / Charnière inférieure pour porte esthétique / bisagras abajo puerta estética
3	4140202754000	Cerniera superiore porta ghisa / Cast iron door top hinge / Obere Scharnier für Tür aus Gusseisen / Charnière supérieure de porte en fonte / Bisagra superior para puerta de arrabio
4	4140202774000	Cerniera superiore completa porta / Complete top door hinge / Komplettes oberes Türscharnier / Charnière complète de porte supérieure / Bisagra de puerta superior completa
5	41402029750	Gruppo porta estetica / Aesthetic door group / Ästhetische Türgruppe / Groupe porte esthétique / Grupo puerta estética
5a	41411700160	Maniglia porta estetica / External door handle / Außentür Griff / Poignée porte extérieure / Tirador puerta exterior
6	4140202884000	Pannello frontale superiore / Upper front panel / Vordere obere Panel / Panneau antérieur supérieur / Panel frontal superior
7	41411628440V	Cerniera inferiore nera / Black lower hinge / Schwarzes unteres Scharnier / Charnière inférieure noire / Bisagra inferior negra
8	437016130	Porta cenere con maniglia / Ash drawer door with handle / Tür des Aschenkastens mit Griff / Porte tiroir à cendres avec poignée / Puerta cajón ceniza con tirador
9	41411623740V	Cerniera acciaio porta cenere / Ash compartment door steel hinge / Aschenklappe Stahlscharnier / Chamier en acier porte compartiment cendre / Bisagra en acero puerta compartimento cenizas
10	437017082	Porta fuoco in ghisa / Cast iron fireplace door / Feuertür aus Gusseisen / Porte foyer en fonte / Puerta hogar de arrabio
11	41411615430V	Deflettore aria / Air deflector / Luftleitblech / Déflecteur aire / Deflector aire
12	41401609930	Supporto frontale superiore / Upper front support / Obere Vordere Gestell / Support panneau antérieur supérieur / Soporte panel frontal superior
13	41411631030P	Fermo magnete / Magnet lock / Verriegelung Magnet / Verrouillage aimant / Bloqueo imán
14	41411599950	Kit serratura ammortizzato / Pressur relief kit / Bausatz Überdruckablauf Brennkammer / Kit decompression chambre combustion / Kit decompression cámara combustion
15	437016041	Cassetto cenere / Ash drawer / Aschenkasten / Tiroir à cendres / Cajón ceniza
16	41301502400V	Braciara ghisa / Cast iron grate / Brennertopf aus Gusseisen / Braser en fonte / Braser en arrabio
17	41401339610	Tappo ispezione vano fumi / Smoke compartment inspection plug / Inspektionsdeckel Rauchabzug / Clapet inspection compartiment fumées / Tapón inspección compartimento humos
18	41800900600	Guarnizione / Gasket / Dichtung / Joint / Junta
19	41200906660	Piedini di appoggio (4 pz.) / Support feet (4 pcs.) / Einstellfüße (4 Stck.) / Vérins d'appui (4 p.es) / Pies de apoyo (4 piezas)
20	41301600800P	Basamento in ghisa / Cast iron base / Basis auf gusseisen / Base en fonte / Base de arrabio
21	4125200040001	Fianco ceramica liscio superiore/inferiore White / Smooth ceramic side upper/lower White / Weiße obere/untere glatte Keramik Seite / Côté céramique lisse supérieur/inférieur Blanc / Lado de cerámica liso superior/inferior Blanco
21	4125200040002	Fianco ceramica liscio superiore/inferiore Black / Smooth ceramic side upper/lower Black / Schwarze obere/untere glatte Keramik Seite / Côté céramique lisse supérieur/inférieur Noir / Lateral de cerámica lisa superior/inferior Negro
22	4125200050001	Fianco ceramica liscio centrale White / Smooth central ceramic side White / Weiße zentrale glatte Keramik Seite / Face centrale lisse en céramique Blanche / Lateral central de cerámica Blanca lisa
22	4125200050002	Fianco ceramica liscio centrale Black / Smooth central ceramic side Black / Schwarze zentrale glatte Keramik Seite / Côté central lisse en céramique Noire / Lateral central de cerámica Negra lisa
23	4125200060001	Fianco ceramica rigato superiore inferiore White / White upper and lower striped ceramic side / Weiße gestreifte Keramik Oberseite oben und unten / Côté supérieur et inférieur en céramique rayée Blanche / Lado acanalado en cerámica superior-inferior Blanco
23	4125200060002	Fianco ceramica rigato superiore inferiore Bordeaux / Bordeaux upper and lower striped ceramic side / Bordeaux gestreifte Keramik Oberseite oben und unten / Côté supérieur et inférieur en céramique rayée Bordeaux / Lado acanalado en cerámica superior-inferior Burdeos
24	4125200070001	Fianco ceramica rigato centrale White / White central striped ceramic side / Weiße zentral gestreifte Keramik Seite / Côté central en céramique rayé Blanc / Lateral central de cerámica con rayas Blancas
24	4125200070002	Fianco ceramica rigato centrale Bordeaux / Bordeaux central striped ceramic side / Bordeaux zentrale gestreifte Keramik Seite / Côté central en céramique rayée Bordeaux / Lateral central de cerámica con rayas Burdeos
25	4140201695000	Profilo alluminio completo / Complete aluminum profile / Komplettes Aluminiumprofil / Profilé aluminium complet / Perfil de aluminio completo
26	41801002300	Paracolpi in silicone Ø 8/5 (2pz) / Silicone bumpers Ø 8/5 (2pcs) / Schlagschutzgummi Ø 8/5 (2 Stck) / Pièces silicone antichoc Ø 8/5 (2pcs) / Anti-golpes en silicona Ø 8/5 (2pzs)
27	4140202914000	Pannello posteriore / Back panel / Hintere Paneel / Panneau postérieur / Panel posterior
28	4140202813000	Flangia pannello ispezione / Inspection panel flange / Flansch der Inspektionsplatte / Bride du panneau d'inspection /

		Brida del panel de inspección
29	41801657900	Magneti (pz.2) / Magnet (pcs.2) / Magnet (stk. 2) / Aimant (pcs.2) / Imán (pz.2)
30	41801601400	Guarnizione coperchio serbatoio / Pellet hopper cover gasket / Deckel Pelletbehälter Dichtung / Joint couvercle réservoir pellet / Junta tapa depósito pellet
31	41402026250	Coperchio completo serbatoio / Complete tank cover / Komplette Tankabdeckung / Couverture complète du réservoir noir / Tapa de depósito completa negra
32	4140202793000	Piastra convogliatore / Conveyor plate / Förderplatte / Plaque de convoyeur / Placa transportadora
33	4140202783000	Staffa bloccaggio schiena / Back locking bracket / Rückenverriegelung Halterung / Support de verrouillage arrière / Soporte de bloqueo trasero
34	4140202804000	Anello superiore top / Upper top ring / Oberer Ring für Top / Anneau supérieur du dessus / Anillo superior de top
35	4140202844000	Staffa bloccaggio ceramiche / Ceramic locking bracket / Keramik Haltebügel / Étrier pour les ceramiques / Soporte de retención de cerámica
36	41402106450	Top completo / Complete top / Komplette Abdeckplatte / Dessus complet / Top completo
36a	4140210652000	Piastrina cerniera Top (4 pz.) / Top hinge plate (4 pieces) / Obere Scharnierplatte (4 Stück) / Plaque de charnière supérieure (4 pièces) / Placa de bisagra superior (4 piezas)
36b	41801701400	Logo MCZ / MCZ logo / MCZ logo / MCZ logo / MCZ logo
36c	41801602200	Maniglia siliconica / silicone handle / Silikongriff / Poignée de silicone / Tirador de silicona
37	4120180	Gommini paracolpi (4 pz) / Rubber bumpers (4 pcs.) / Schlagschutzgummi (4 Stck) / Pièces caoutchouc antichoc (4 pcs) / Cauchitos anti-golpes (4 pz)

FLOW COMFORT AIR 10 M1

Gruppo camera di combustione / Combustion chamber group / Verbrennungskammer Gruppe / Group de chambre de combustion / Grupo cámara de combustión

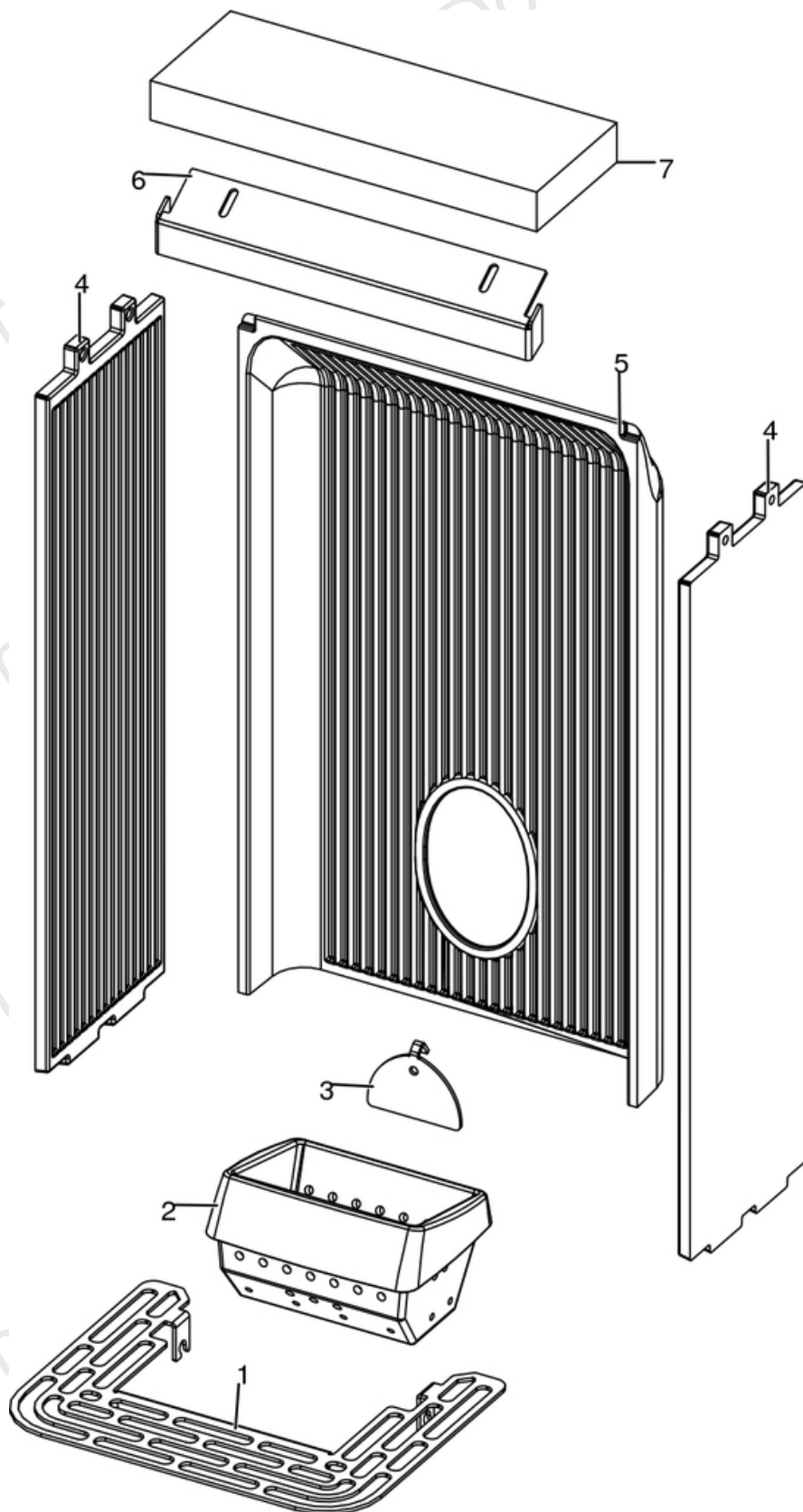

N°	Codice/Code	Descrizioni / Description / Beschreibung / Description / Descripción
1	41411634830V	Griglia focolare / Fire Box Grille / Feuerstellenrost / Grille Foyer / Rejilla Hogar
2	41301502400V	Braciara ghisa / Cast iron grate / Brennertopf aus Gusseisen / Brasero en fonte / Brasero en arrabio
3	41411613530V	Deflettore pellet / Pellet deflector / Pellet Leitblech / Deflecteur pellet / Deflector pellet
4	41301502500V	Fianco ghisa / Cast iron side / Seite aus Guß / Côté en fonte / Placa lateral de arrabio
5	41301502600V	Schiena ghisa / Cast iron back / Rückwand aus Gusseisen / Dossieret en fonte / Parte trasera en arrabio
6	41411615430V	Deflettore aria / Air deflector / Luftleitblech / Déflecteur aire / Deflector aire
7	41151600200	Deflettore focolare in vermiculite / Vermiculite deflector / Leitblech aus Vermiculite / Déflecteur en vermiculite / Deflector en vermiculite

FLOW COMFORT AIR 10 M1

Porta fuoco / Fire door / Feuertür / Porte foyer / Puerta hogar

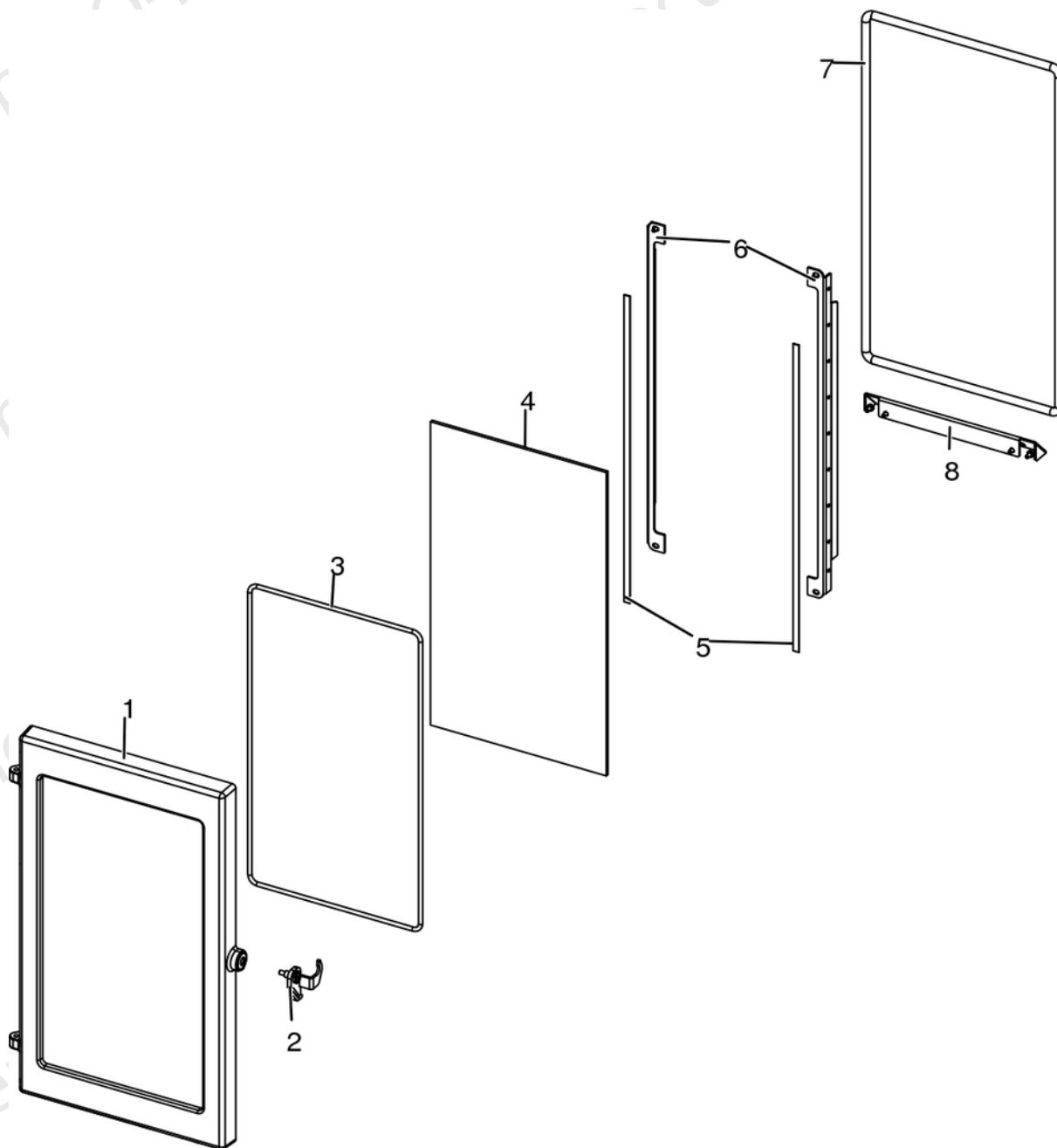

N°	Codice/Code	Descrizioni / Description / Beschreibung / Description / Descripción
1	41301602500V	Telaio porta fuoco / Fire door frame / Feuertürrahmen / Cadre porte foyer / Armazón puerta de arrabio
2	41411616560	Maniglia porta nera / Door Handle / Türgriff / Poignée porte / Tirador
3	41801603300A	Guarnizione Ø5 5mt / Gasket Ø5 5mt / Dichtung Ø5 5mt / Joint Ø5 5mt / Junta Ø5 5mt
3	41801603300B	Guarnizione Ø5 50mt / Gasket Ø5 50mt / Dichtung Ø5 50mt / Joint Ø5 50mt / Junta Ø5 50mt
3	41801603300C	Guarnizione Ø5 5mt + silicone / Gasket Ø5 5mt + silic / Dichtung Ø5 5mt + Silikon / Joint Ø5 5mt + silic / Junta Ø5 5mt
4	41701600300	Vetroceramico porta ghisa / Cast iron door glass / Glaskeramikscheibe Tür aus Gusseise / Vitrocéremique porte en fonte / Cristal cerámico puerta en arrabio
5	4120573A	Guarnizione a nastro 8 mm (5 mt.) per porta / Door strip gasket 8 mm (5 m) / Türbanddichtung 8 mm (5 m) / Joint ruban 8 mm (5 m) pour porte / Guarnición de cinta para puerta 8 mm (5 m)
5	4120573B	Guarnizione a nastro 8 mm (50 mt.) per porta / Door strip gasket 8 mm (50 m) / Türbanddichtung 8 mm (50 m) / Joint ruban 8 mm (50 m) pour porte / Guarnición de cinta para puerta 8 mm (50 m)

6	41411622030V	Profilo fermavetro / Fastening bracket profile / Haltebügel für Scheibebefestigung Profil / Profil patte de fixation / Perfil fermacristal
7	4120104A	Cordino fibroceramico Ø 12 mm (5 mt.) / Ceramic fibre cord Ø 12 mm (5 m.) / Keramikfaserschnur Ø 12 mm (5 m) / Cordon en fibre céramique Ø 12 mm (5 m) / Junta a cuerda de fibra cerámica Ø 12 mm (5 m)
7	4120104B	Cordino fibroceramico Ø 12 mm (50 mt.) / Ceramic fibre cord Ø 12 mm (50 m.) / Keramikfaserschnur Ø 12 mm (50 m) / Cordon en fibre céramique Ø 12 mm (50 m) / Junta a cuerda de fibra cerámica Ø 10 mm (52 m)
7	41201041	Kit sostituzione cordino (cordino+silicone) Ø 12 mm / Cord replacement kit (cord + silicon) Ø 12 mm / Schnuraustauschsatz (Schnur+Silikon) Ø 12 mm / Kit remplacement cordon (cordon + silicone) Ø 12 mm / Kit sustitución junta a cuerda (junta a cuerda+silicón) Ø 12 mm
8	41411622130V	Scivolo cenere / Ash ramp / Aschenrutsche / Glissière cendre / Tobogán ceniza

FLOW COMFORT AIR 10 M1

Gruppo accensione / Ignition group / Entzündung Gruppe / Groupe d'allumage / Grupo ignición

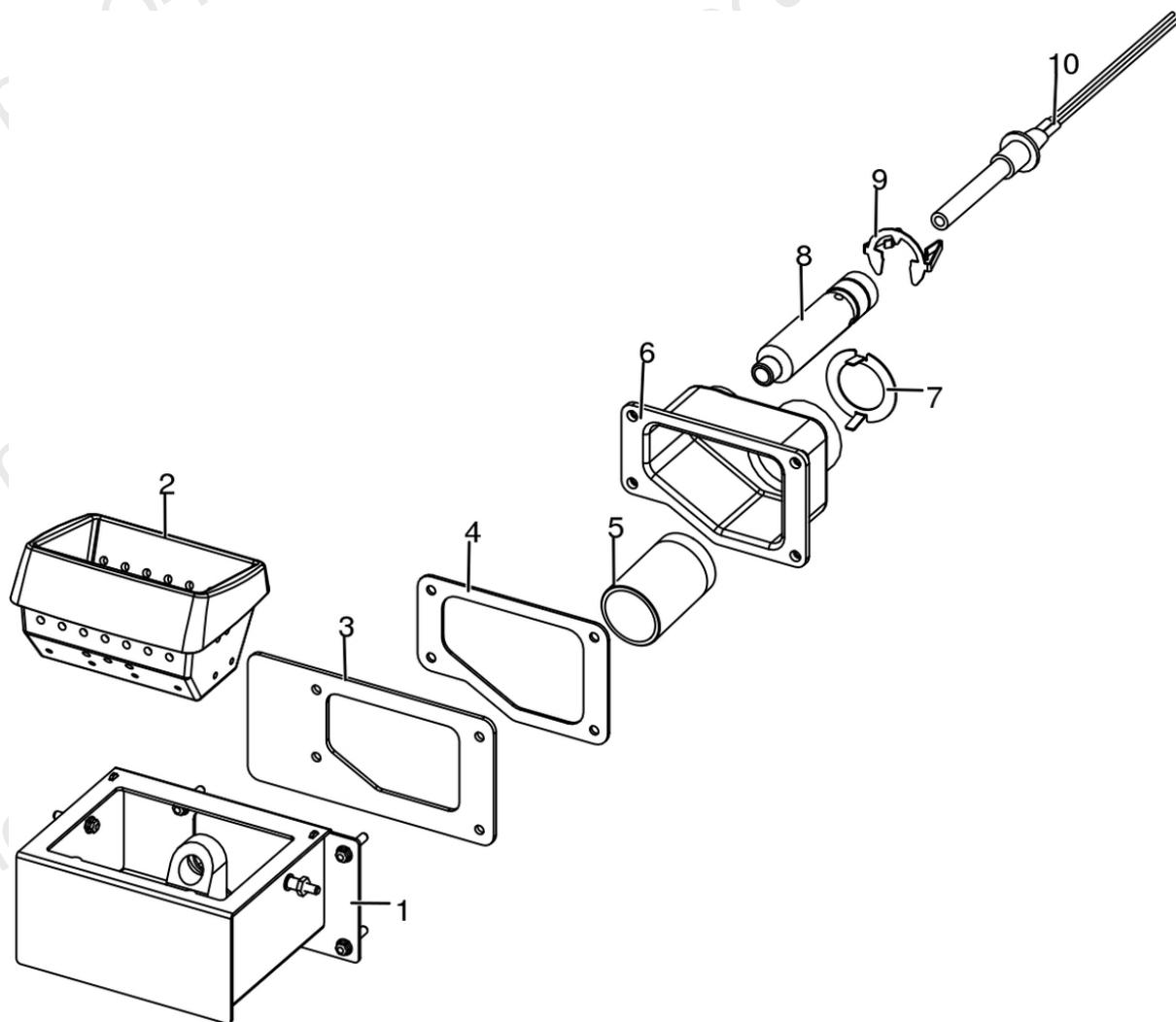

N°	Codice/Code	Descrizioni / Description / Beschreibung / Description / Descripción
1	41411613140V	Tasca braciere / Combustion pot container / Brenntopfkasten / Récipient brasero / Contenedor brasero
2	41301502400V	Braciere ghisa / Cast iron grate / Brennertopf aus Gusseisen / Brasero en fonte / Brasero en arrabio
3	41801601500	Guarnizione tasca braciere / Combustion pot container gasket / Brenntopfkasten Dichtung / Joint récipient brasero / Junta contenedor brasero
4	41801602300	Guarnizione codolo / Gasket / Dichtung / Joint / Junta
5	41501701599	Manicotto potenziamento accensione / Combustion air extension pipe / Zusatzrohr für Nachrüstung / Tuyau amélioration allumage / Tubo impulso de encendido
6	41311803500	Codolo / Tool chuck / Einspannschaft / Outil d'emmanchement / Mango
7	41401629410	Regolatore ingresso aria comburente / Combustion air intake adjuster / Regler Eingang Verbrennungsluft / Régulateur arrivée air comburant / Regulador entrada aire comburente
8	41601601000	Condotto candelella / Sparkplug Conduit / Zündkerzenkanal / Conduit Bougie / Conducto Bujía
9	41201601500	Anello arresto candelella / Sparkplug stop / Zündkerzestopper / Butée bougie / Tope bujía
10	41451308101	Candelella 315 Watt / Sparkplug 315 Watt / Zündkerze 315 Watt / Bougie 315 Watt / Bujía 315 Watt
10	41451308150	Kit 25 candelella 315 Watt / 25 Sparkplugs 315 Watt kit / Bausatz 25 Zündkerzen 315 Watt / Kit 25 Bougies 315 Watt / Kit 25 Bujías 315 Watt
10	41452009900	Candelella 300 Watt / Sparkplug 300 Watt / Zündkerze 300 Watt / Bougie 300 Watt / Bujía 300 Watt

FLOW COMFORT AIR 10 M1

Gruppo caricamento pellet acciaio / Pellet feed group in steel / Pellet Fördergruppe aus Stahl / Groupe de chargement pellet en acier / Grupo de carga pellet acero

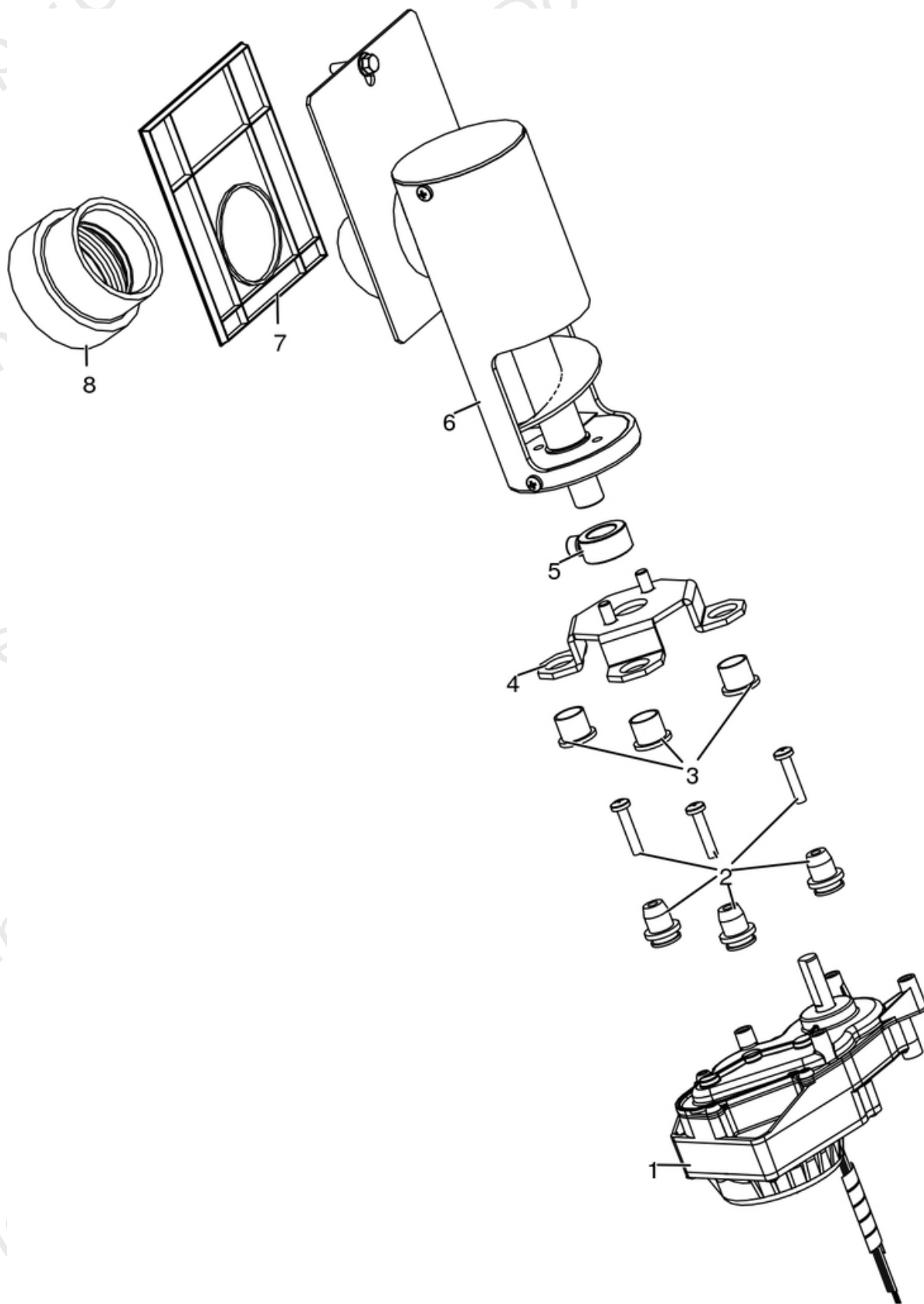

N°	Codice/Code	Descrizioni / Description / Beschreibung / Description / Descripción
1	41451702200	Motoriduttore brushless / Brushless reduction motor / Brushless Getriebemotor / Motoréducteur brushless / Motorreductor brushless
1	41452000500	Cavo motoriduttore / Reduction motor cable / Kabel Getriebemotor / Câble motoréducteur / Cable motorreductor
2	41801703700	Gommini antivibrante / Vibration damper rubber / Rammenschutz Gummi / Caoutchouc antivibratoire / Cauchitos antivibración
3	41201800700	Boccola (3 pz) / Bushing (3 pcs) / Buchse (3 Stk) / Douille (3 pcs) / Abrazadera (3 pzs)
4	41411779331	Supporto coclea "Ragno" / Pellet feed screw bracket "spider" / "Spinne" Schenke Gestell / Support vis sans fin "Araignée" / Sopoite coclea "Araña"
5	4120398	Connettore motoriduttore-coclea / Reduction motor-feed screw connector / Verbindung Getriebemotor-Schnecke / Connecteur motoréducteur-vis sans fin / Conector motorreductor-cóclea
6	41411800151	Gruppo alimentazione completo / Complete feed screw / Komplette Förderschnecke / Vis sans fin complète / Coclea de carga completa
7	41801600400	Guarnizione gruppo caricamento / Gasket / Dichtung / Joint / Junta
8	41801702600	Guarnizione / Gasket / Dichtung / Joint / Junta

FLOW COMFORT AIR 10 M1

Gruppo aria comburente / Combustion air group / Verbrennungsluft Gruppe / Groupe air comburant / Grupo aire comburente

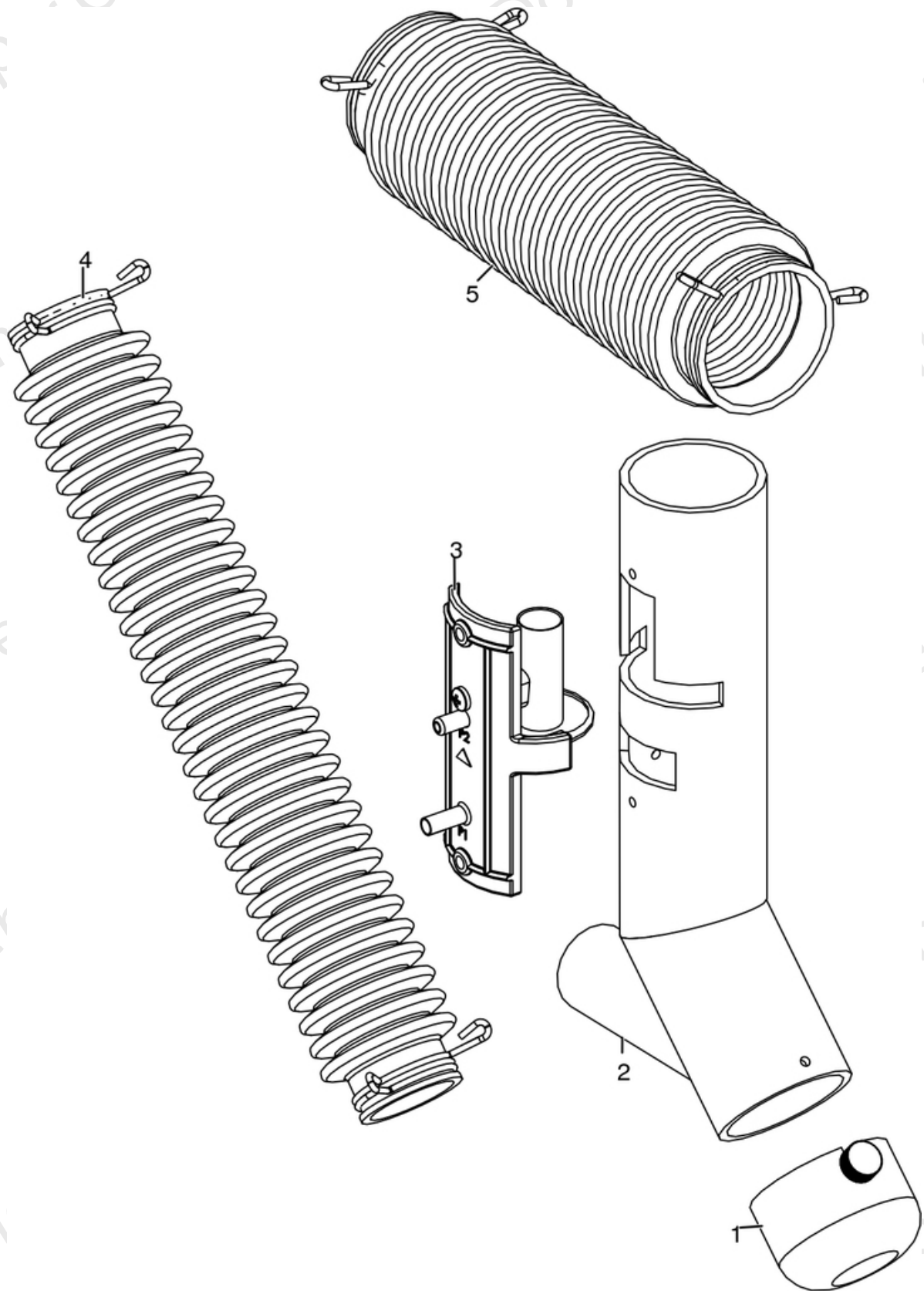

N°	Codice/Code	Descrizioni / Description / Beschreibung / Description / Descripcion
1	41401036100	Filtro antipolvere / Anti-dust filter / Staubschutzfilter / Filtre antipoussière / Filtro de protección polvo
2	41601601800V	Tubo aspirazione nero / Black air inlet pipe / Schwarz Lufteingangsrohr / Tuyau entrée d'air noir / Tubo entrada aire negro
3	41601301851	Componente rilevamento portata aria / Air flow measure component / Bauteil für Messung der Luftmenge / Composent pour la mesuration de la quantité d'air / Componente por la medida de l'aire
4	41801601900	Tubo aspirazione pulizia vetro / Inlet pipe for cleaning glass air / Glasreinigungs Lufteingangsrohr / Tuyau entrée pour l'aire de nettoyage du vitre / Tubo entrada por l'aire de limpieza vidrio
5	41801601700	Tubo aspirazione camera combustione / Combustion chamber aspiration tube / Verbrennungskammer Förderrohr / Tuyay aspiration air chambre de combustion / Tubo aspiración aire cámara de combustión

FLOW COMFORT AIR 10 M1

Gruppo caricamento pellet alluminio / Pellet feed group aluminium / Pellet Fördergruppe Aluminium /
Groupe de chargement pellet aluminium / Grupo de carga pellet aluminio

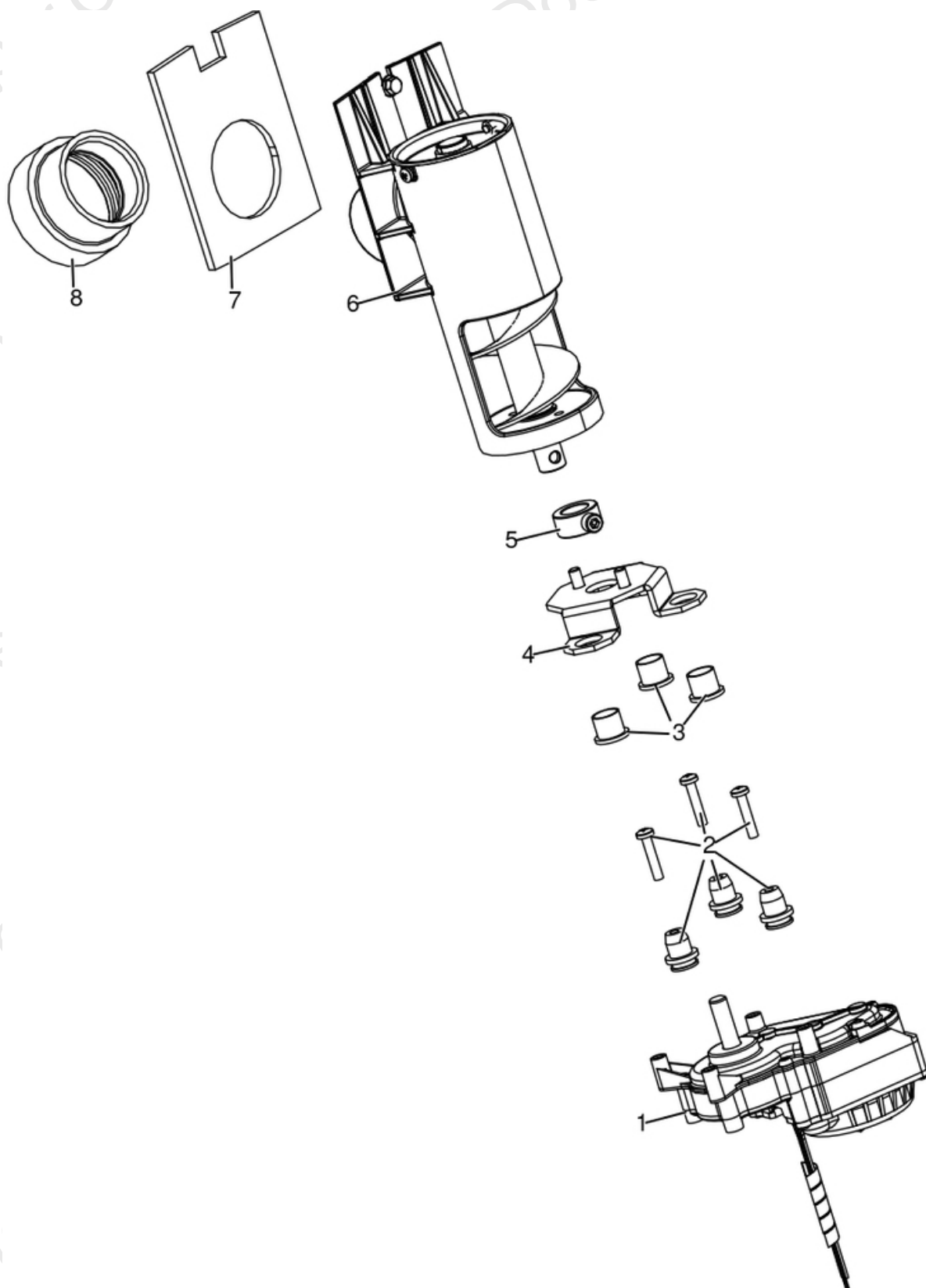

N°	Codice/Code	Descrizioni / Description / Beschreibung / Description / Descripción
1	41451702200	Motoriduttore brushless / Brushless reduction motor / Brushless Getriebemotor / Motoréducteur brushless / Motorreductor brushless
2	41801703700	Gommini antivibrante / Vibration damper rubber / Rammenschutz Gummi / Caoutchouc antivibratoire / Cauchitos antivibración
3	41201800700	Boccola (3 pz) / Bushing (3 pcs) / Buchse (3 Stk) / Douille (3 pcs) / Abrazadera (3 pzs)
4	41411779331	Supporto coclea "Ragno" / Pellet feed screw bracket "spider" / "Spinne" Schenke Gestell / Support vis sans fin "Araignée" / Soporte coclea "Araña"
5	4120398	Connettore motoriduttore-coclea / Reduction motor-feed screw connector / Verbindung Getriebemotor-Schnecke / Connecteur motoréducteur-vis sans fin / Conector motorreductor-cóclea
6	41402002050	Gruppo alimentazione / Complete feed screw / Komplette Förderschnecke / Vis sans fin complète / Coclea de carga completa
7	41802000300	Guarnizione / Gasket / Dichtung / Joint / Junta
8	41801702600	Guarnizione / Gasket / Dichtung / Joint / Junta

FLOW COMFORT AIR 10 M1

Gruppo elettrico ed elettronico / Electrical and electronic group / Elektrische und elektronische Gruppe /
Groupe électrique et électronique / Grupo eléctrico y electrónico

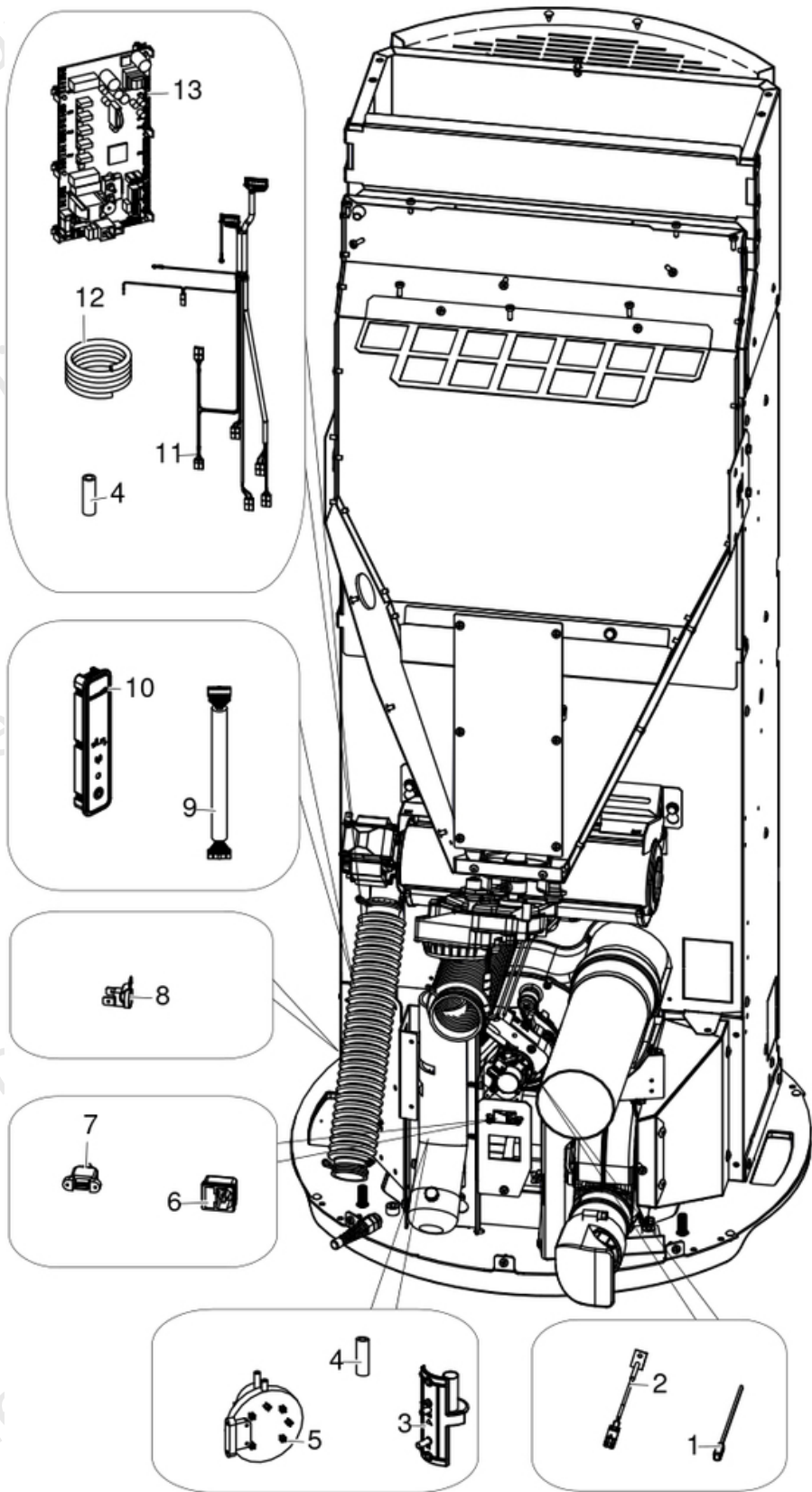

N°	Codice/Code	Descrizioni / Description / Beschreibung / Description / Descripcion
1	4160386	Sonda temperatura ambiente/acqua / Room/Water temperature sensor / Raum- Wassertemperaturfühler / Sonde température ambiante/eau / Sonda temperatura ambiente/agua
2	41451703600	Sonda fumi con flangia con morsetti L.980 / Smoke sensor with flange with terminal board L.980 / Rauchsonde mit Flansche mit Klemmenbrett L.980 / Sonde fumées avec bride avec serre-câble L.980 / Sonda humos con brida con borne L.980
3	41601301851	Componente rilevamento portata aria / Air flow measure component / Bauteil für Messung der Luftmenge / Composent pour la mesuration de la quantité d'air / Componente por la medida de l'aire
4	4120631A	Tubicino siliconico - 5m / Silicon tube - 5m / Silikonrohr - 5m / Petit tuyau en silicone - 5m / Tubo silicónico - 5m
5	41451003700	Pressostato / Pressure switch / Druckschalter / Pressostat / Presostato
6	41451104100	Presa con fusibile / Socket with fuse / Steckdose mit Sicherung / Prise avec fusible / Toma con fisible
7	41451403200	Cavo USB da pannello L.500 / USB Cable from display L.500 / USB Kabel von Notfalldisplay L.500 / Câble USB de panneau L.500 / Cable USB del panel L.500
8	412007004	Clickson 110°C / Clickson 110°C / Clickson 110°C / Clickson 110°C / Clickson 110°C
9	41451801600	Cavo flat 20 vie L.600 mm / Flat cable 20 pin L.600 mm / Flat-Kabel 20polig L.600 mm / Cable flat 20 voies L.600 mm / Flat cable 20 vias L.600 mm
10	41451602802	Pannello di emergenza Wireless / Wireless emergency display / Wireless Notfall-Blende / Panneau d'urgence wireless / Panel emergencia wireless
11	41451904700	Cablaggio elettrico Maestro / Maestro electrical wiring / Elektrische Verkabelung Maestro / Câblage électrique Maestro / Cableado eléctrico Maestro
12	41801902500	Spirale Rilsan (30 m.) / Rilsan spiral (30 m.) / Spirale Rilsan (30 M.) / Spirale Rilsan (30 m.) / Espiral Rilsan (30 m.)
12	41801902500A	Spirale Rilsan (5 spire) / Rilsan spiral (5 coils) / Spirale Rilsan (5 Windungen) / Spirale Rilsan (5 spires) / Espiral Rilsan (5 espire)
13	41451904300	Scheda madre MAESTRO / Motherboard MAESTRO / Hauptplatine MAESTRO / Carte mère MAESTRO / Tarjeta madre MAESTRO
13	41451904300A	Sensirion / Sensirion / Sensirion / Sensirion / Sensirion

FLOW COMFORT AIR 10 M1

Gruppo fumi / Smoke group / Rauchgruppe / Groupe fumées / Grupo de humos

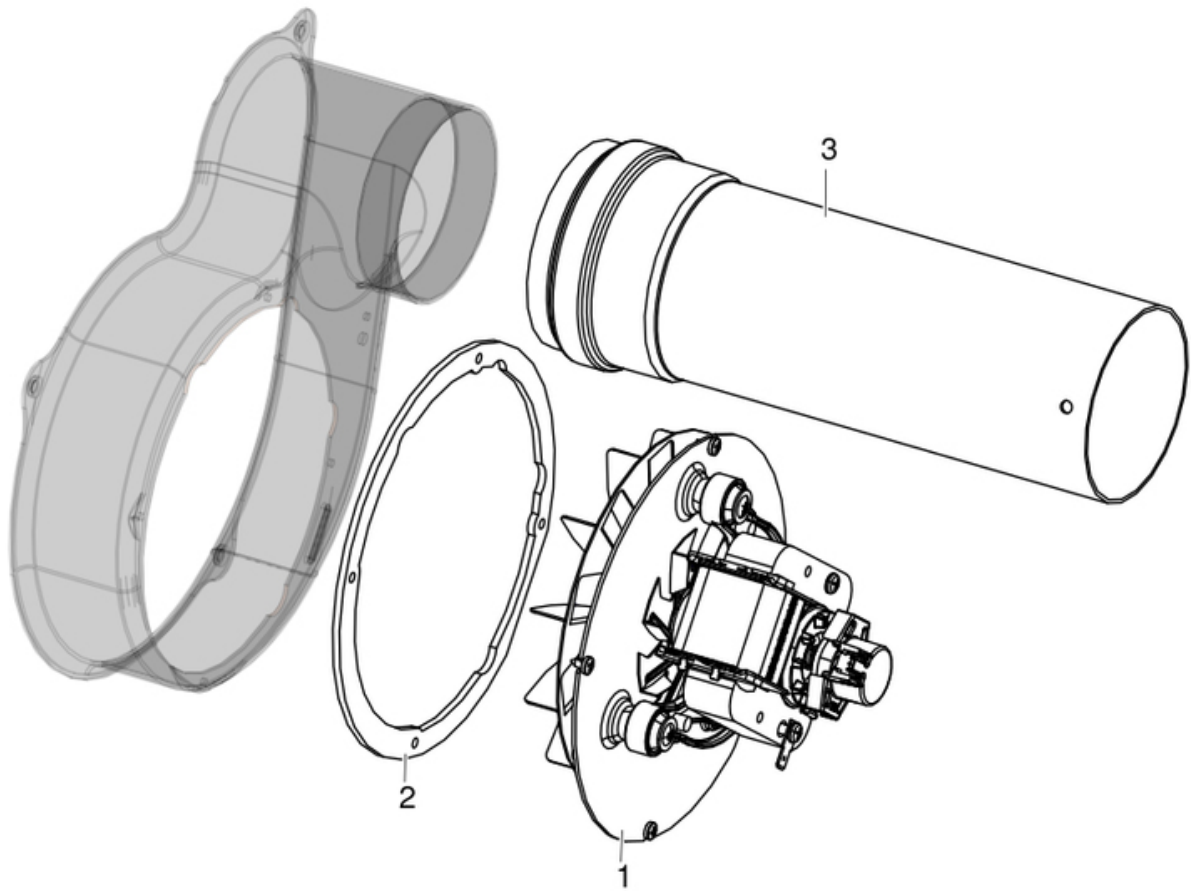

N°	Codice/Code	Descrizioni / Description / Beschreibung / Description / Descripción
1	41451503200	Ventilatore fumi stagno / Air-tight smoke fan / Luftdichtes Rauchgasgebläse / Ventilateur fumées étanche / Ventilador humos hermético
1	41452009200	Encoder per ventilatore fumi marchio EMC / Encoder for EMC smoke fan / Encoder für EMC Rauchgasgebläse / Encoder pour ventilateur des fumées marque EMC / Encoder para ventilador humos marca EMC
2	41801600800	Guarnizione ventilatore fumi / Smoke exhaust fan gasket / Dichtung Rauchabsauggebläse / Joint Ventilateur aspiration fumées / Junta ventilador aspiración humos
3	41601603000	Tubo Ø8 L.25 con guarnizione / Pipe Ø8 L.25 with gasket / Rohr Ø8 L.14 mit Dichtung / Tuyau Ø8 L.25 avec joint / Tubo Ø8 L.25 con guarnición

FLOW COMFORT AIR 10 M1

Gruppo ventilazione / Ventilation group / Lüftungsgruppe / Groupe de ventilation / Grupo de ventilación

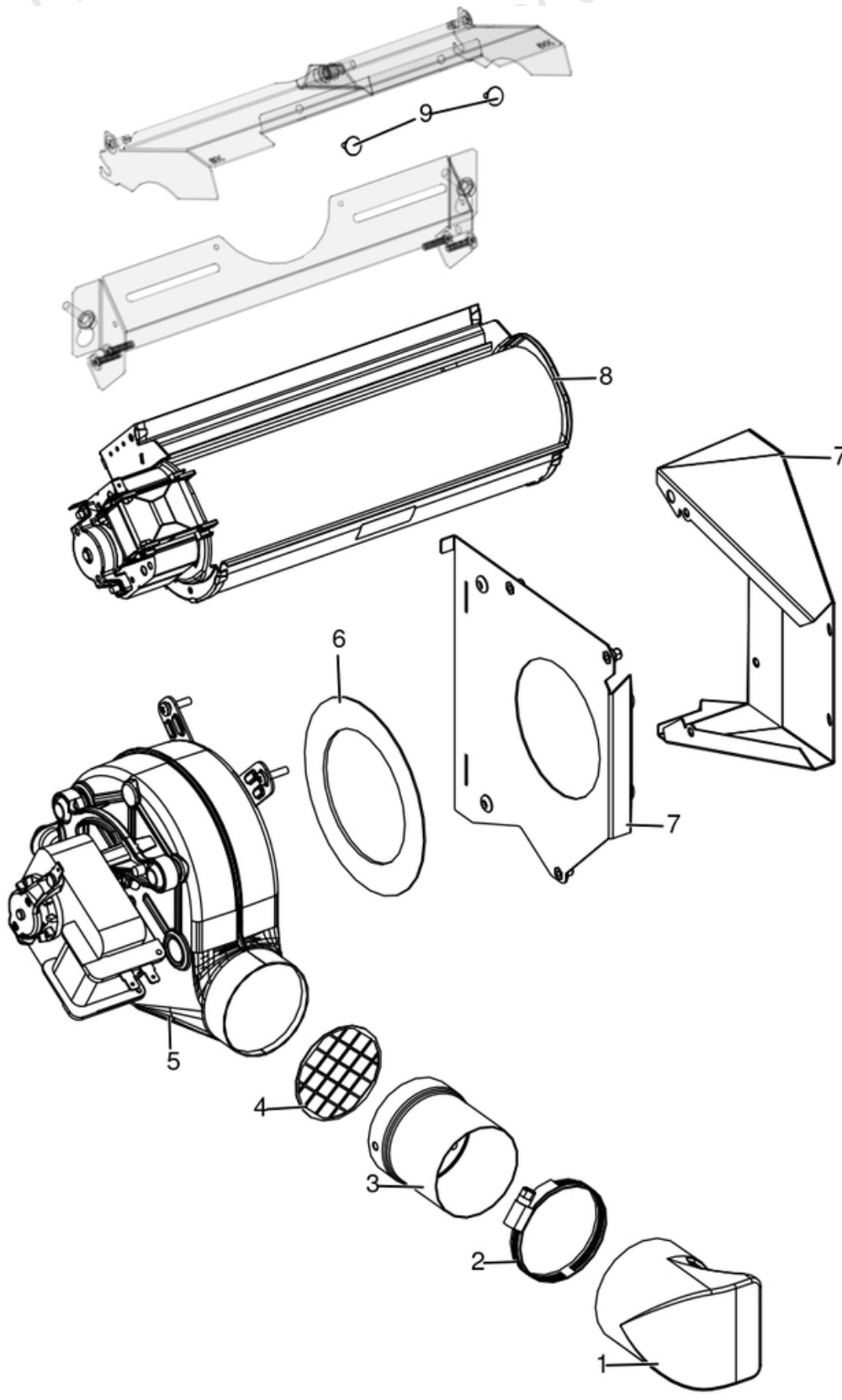

N°	Codice/Code	Descrizioni / Description / Beschreibung / Description / Descripción
1	41801605300	Bocchetta posteriore in silicone / Silicone rear air outlet / Luftauslass aus Silikon / Diffuseur air en silicone / Boquilla aire en silicona
2	41200902000	Fascette Ø 64-76 mm (2 pz) / Clamps Ø 64-76 mm (2 pcs) / Rohrschellen Ø 64-76 mm (2 Stck) / Colliers Ø 64-76 mm (2 pcs) / Bandas Ø 64-76 mm (2 pzs)
3	41601601700V	Prolunga ventilatore centrifugo / Fan extension / Gebläse Verlängerung / Rallonge ventilateur / Extensión ventilador
4	41331600410	Griglia protezione prolunga ventilatore / Fan extension protection grille / Schutzgitter Gebläseverlängerung / Grille de protection prolongation ventilateur / Rejilla de protección prolongación ventilador
5	41451503300	Ventilatore centrifugo / Air fun / Lufgebläse / Ventilateur air / Ventilador aire
6	41801601600	Guarnizione ventilatore / Fan gasket / Dichtung des Gebläses / Joint du ventilateur / Junta ventilador
7	41401609230	Tamponazione completa / Complete filling / Komplett Stopfung / Tampon complét / Taponado completo
8	41451600800	Ventilatore aria / Air fan / Luftgebläse / Ventilateur air / Ventilador aire
9	41801002300	Paracolpi in silicone Ø 8/5 (2pz) / Silicone bumpers Ø 8/5 (2pcs) / Schlagschutzgummi Ø 8/5 (2 Stck) / Pièces silicone antichoc Ø 8/5 (2pcs) / Anti-golpes en silicona Ø 8/5 (2pzs)