

**SABA 14**

Gruppo estetico / Aesthetic group / Aesthetische Gruppe / Groupe esthétique / Grupo estético

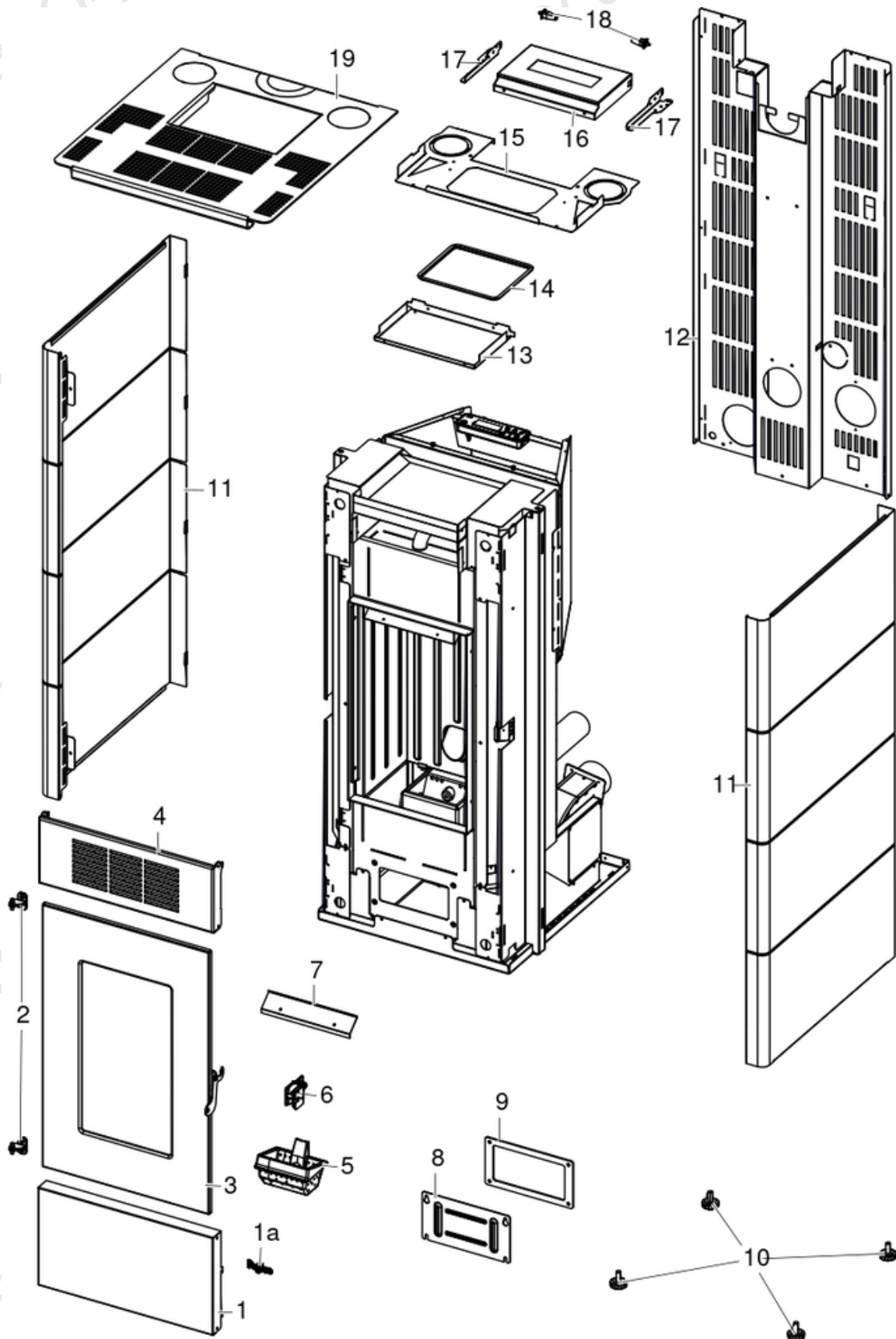

N°	Codice/Code	Descrizioni / Description / Beschreibung / Description / Descripción
1	4D24020917361	Pannello finitura inferiore / Bottom finishing panel / Bodenveredelung Platte / Panneau de finition inférieur / Panel de acabado inferior
1a	4D120189010	Logo Pegaso / Pegaso logo / Logo Pegaso / Pegaso Kennzeichen / Logo Pegaso
2	41201504460	Cerniera porta (2 pz.) / Door hinge (2 pc.) / Tür Scharnier (2 Stk.) / Charnière porte (2 pc.) / Bisagra puerta (2)
3	4D245GP20007	Porta completa / Complete door / Komplette Tür / Porte complète / Puerta completa
4	4D24020927361	Pannello finitura superiore / Top finishing panel / Obere Verkleidung / Panneau de garniture supérieur / Panel de acabado superior
5	4D13016602061	Braciare / Grate / Brennschale / Braserio / Braserio
6	4D24015841361	Kit decompressione camera di combustione / Pressure relief kit / Bausatz Überdruckablauf Brennkammer / Kit decompression chambre de combustion / Kit decompression cámara de combustión
7	4D242209013	Deflettore aria / Air deflector / Luftleitblech / Déflecteur aire / Deflector aire
8	41401339610	Tappo ispezione vano fumi / Smoke compartment inspection plug / Inspektionsdeckel Rauchabzug / Clapet inspection compartiment fumées / Tapón inspección compartimento humos
9	41800900600	Guarnizione / Gasket / Dichtung / Joint / Junta
10	4D120201020	Piedino (4 pz) / Feet (4 Pcs) / Füße (4 Stck) / Vérins (4 Pcs) / Pies (4 pz)
11	4D24020929391	Fianco Sx-Dx Rosso / Left/right side red / Linke/Rechte Seite Rot / Panneau gauche/droit rouge / Panel IZDO/DCHO rojo
11	4D24020929396	Fianco Sx-Dx Bianco / Left/right side white / Linke/Rechte Seite Weiß / Panneau gauche/droit blanc / Panel IZDO/DCHO blanco
11	4D24020929340	Fianco Sx-Dx / LH-RH side / L.-R. Seite / Côté droite et gauche / Lateral IZDO - DCHO
12	4D241209063	Schiena / Rear back / Rückseite / Dos / Trasera
13	4D241209053	Controcoperchio serbatoio / Hopper counter top / Pellet Tank-Gegendeckel / Contre-couvercle de réservoir / Contra-tapa del tanque
14	4D18013016	Guarnizione 155X190 mm / Gasket 155X190 mm / Dichtung 155x190 mm / Joint 155X190 mm / Junta 155X190 mm
15	4D241209023	Coperchio serbatoio / Tank cover / Tankdeckel / Couvercle de réservoir / Cubierta de tanque
16	4D241209113	Staffa superiore coperchio pellet / Upper bracket for pellet cover / Obere Halterung für Pelletabdeckung / Support supérieur pour couvercle à pellets / Soporte superior para tapa de pellet
17	4D24020911363	Coperchio pellet / Pellet hopper cover / Deckel Pelletbehälter / Couvercle réservoir pellet / Tapadera depósito pellet
18	4D14013054C	Cerniera a innesto (2 pz) / Hinge (2 pc) / Scharnier (2 Stck) / Charnière (2 pcs) / Bisagra (2 pzs)
19	4D24020928363	Top / Top / Top / Dessus / Top

**SABA 14**

Gruppo camera di combustione / Combustion chamber group / Verbrennungskammer Gruppe / Group de chambre de combustion / Grupo cámara de combustión

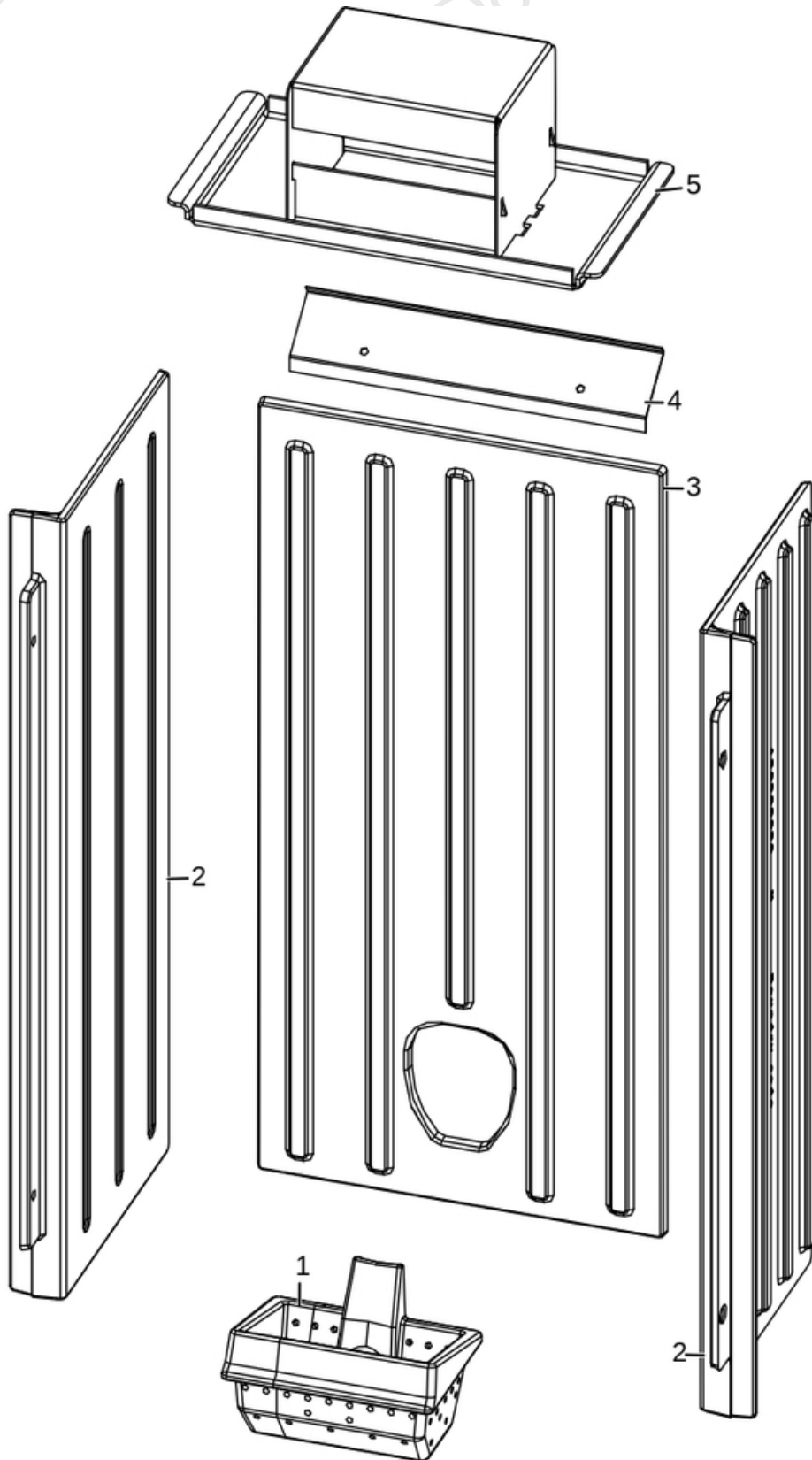

N°	Codice/Code	Descrizioni / Description / Beschreibung / Description / Descripción
1	4D13016602061	Braciere / Grate / Brennschale / Brascero / Brascero
2	4D13020903061	Tavella in ghisa / Cast iron panel / Gusseisenpaneel / Panneau en fonte / Mesa de hierro fundido
3	4D13020904061	Tavella in ghisa schiena / Back cast iron panel / Gusseisenpaneel hinten / Panneau postérieur en fonte / Mesa trasera de hierro fundido
4	4D242209013	Deflettore aria / Air deflector / Luftleitblech / Déflecteur aire / Deflector aire
5	4D240209140	Deflettore fiamma + Castello / Deflector / Leitblech / Déflecteur / Deflector

**SABA 14**

Porta fuoco / Fire door / Feuertür / Porte foyer / Puerta hogar

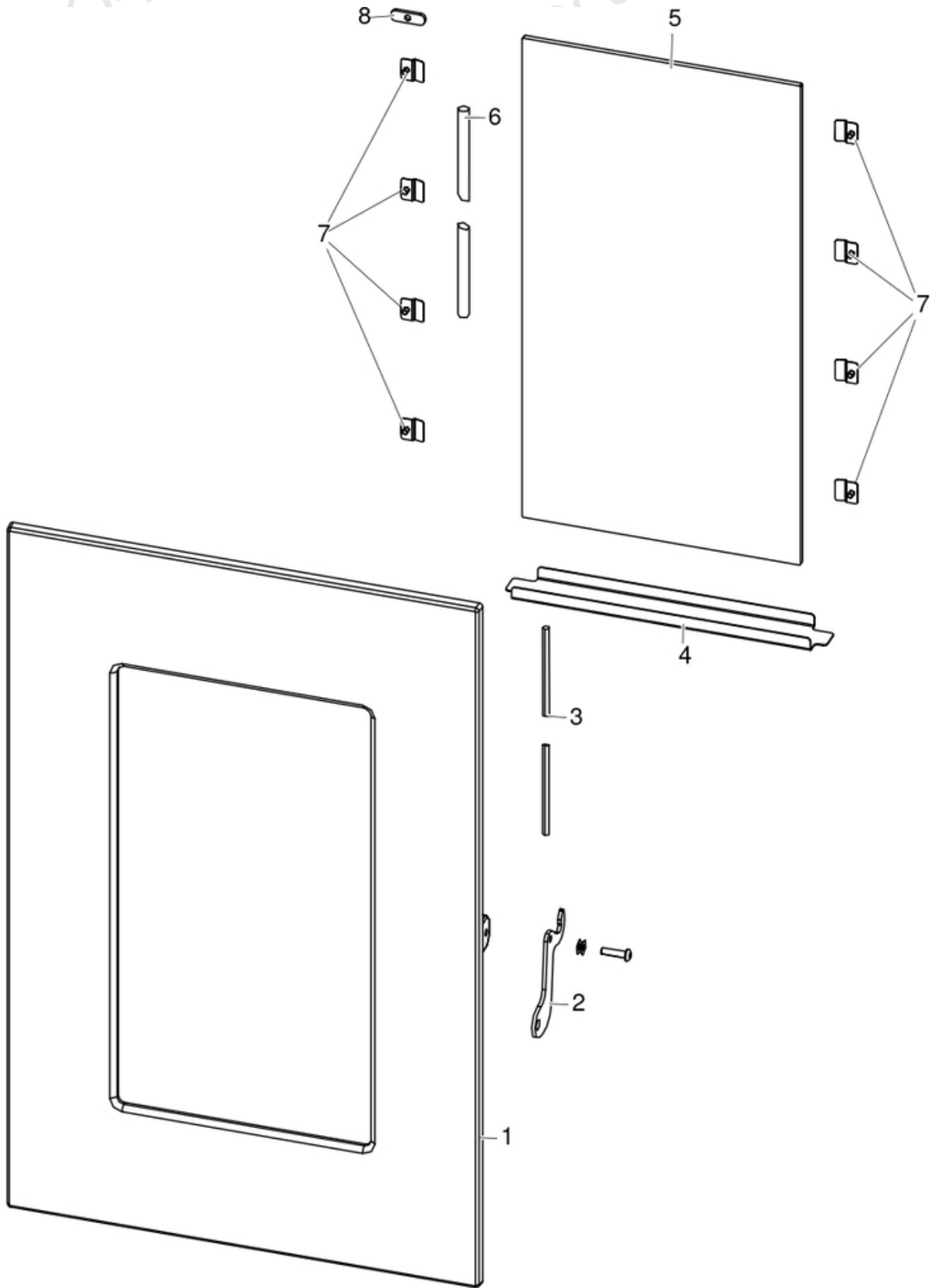

N°	Codice/Code	Descrizioni / Description / Beschreibung / Description / Descripción
1	4D13020901061	Porta in ghisa / Cast iron door / Tür aus Gusseisen / Porte en fonte / Puerta en arrabio
2	4D24015868161	Maniglia / Handle / Griff / Poignée / Tirador
3	4D18013034A	Guarnizione Tricotex D.6mm (5m) / Gasket Tricotex D.6mm (5m) / Dichtung Tricotex D.6mm (5m) / Joint Tricotex D.6mm (5m) / Junta Tricotex D.6mm (5m)
3	4D18013034B	Guarnizione Tricotex D.6mm (50m) / Gasket Tricotex D.6mm (50m) / Dichtung Tricotex D.6mm (50m) / Joint Tricotex D.6mm (50m) / Junta Tricotex D.6mm (50m)
4	4D241209163	Raccogli cenere / Ash holder / Aschensammeln / Collecteur de cendres / Recoger cenizas
5	4D170209010	Vetro ceramico sfilettato 468X251X5 / Filleted ceramic glass 468X251X5 / Filetiertes Keramikglas 468X251X5 / Vitre céramique fileté 468X251X5 / Vidrio cerámico fileteado 468X251X5
6	4D18013021A	Guarnizione treccia nera D.10 - 5 M / Black twist gasket D.10 - 5 M / Dichtung D.10 - 5 M / Joint tresse noire D.10 - 5 M / Junta D.10 - 5 M
6	4D18013021B	Guarnizione treccia nera D.10 - 50 M / Black twist gasket D.10 - 50 M / Dichtung D.10 - 50 M / Joint tresse noire D.10 - 50 M / Junta D.10 - 50 M
7	4D2401317703	Fermavetro (pz.2) / Glass fastening brackets (pcs.2) / Haltebügel für Scheibenbefestigung (stk.2) / Etrier de fixation de la vitre (pcs.2) / Retendor del cristal (pz.2)
8	4D240157991	Asola porta / Door lock hole / Schleife für Türblockierung / Boucle de porte / Ojal de la puerta

**SABA 14**

Gruppo caricamento pellet / Pellet feed group / Pellet Fördergruppe / Groupe chargement du pellet / Grupo de carga pellet

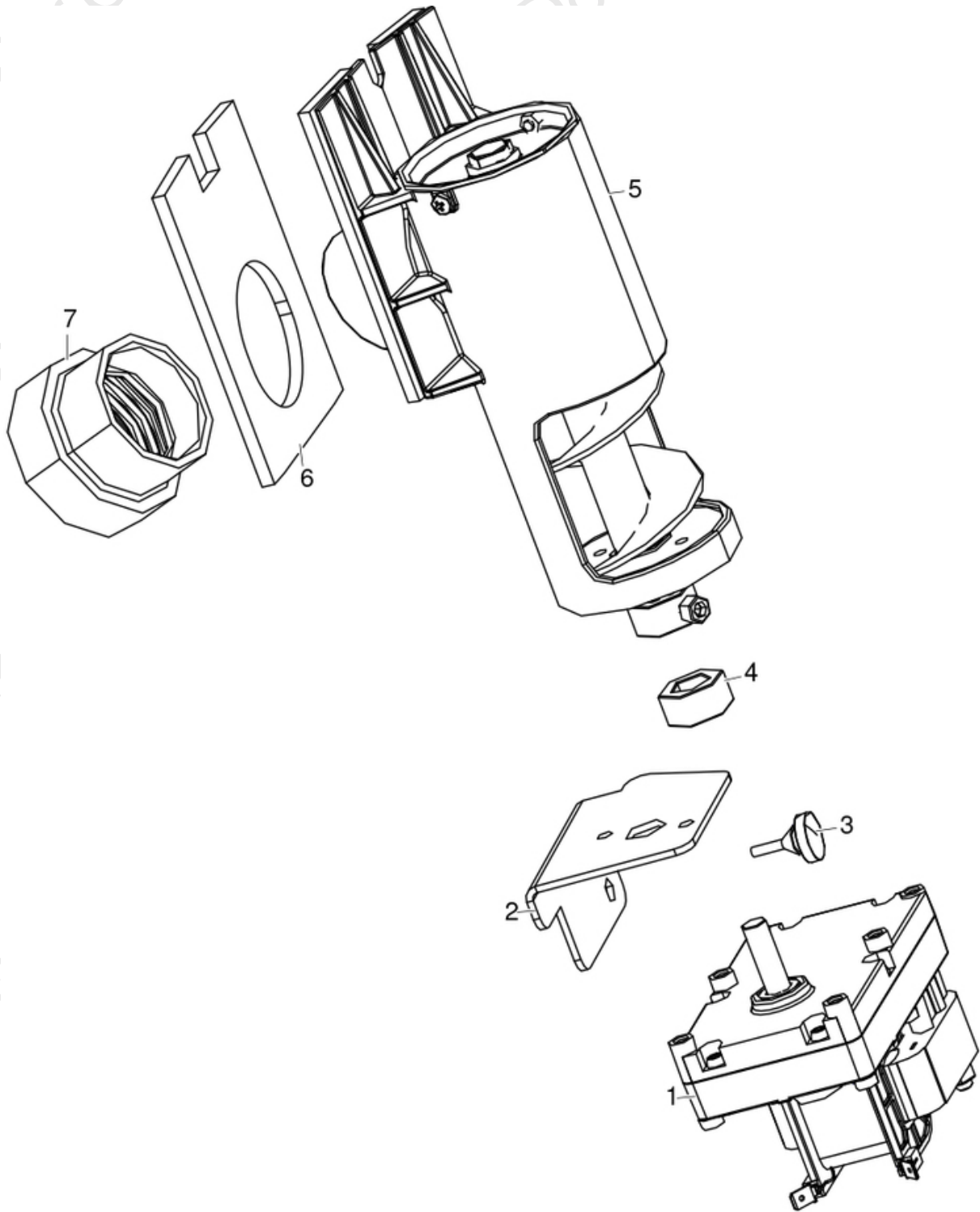

N°	Codice/Code	Descrizioni / Description / Beschreibung / Description / Descripcion
1	4D145181020	Motoriduttore 2 rpm / Reduction motor 2 rpm / Getriebemotor 2 rpm / Motoréducteur 2 rpm / Motorreductor 2 rpm
2	4D240209133	Staffa motoriduttore / Gearmotor bracket / Getriebemotor Halterung / Support de motoréducteur / Soporte motorreductor
3	4D120172010K	Kit 4 paracolpi / Kit 4 Bumpers / Kit 4 Schlagschutzgummi / Kit 4 pièces antichoc / Kit 4 anti-golpes
4	4120398	Connettore motoriduttore-coclea / Reduction motor-feed screw connector / Verbindung Getriebemotor-Schnecke / Connecteur motoréducteur-vis sans fin / Conector motorreductor-cóclea
5	4D140209050	Coclea con albero / Feed screw with shaft / Förderschnecke mit Welle / Vis d'alimentation avec arbre / Sinfin con eje
6	41802000300	Guarnizione con ceramica gruppo alimentazione / Gasket with ceramic - power supply group / Dichtung mit Keramik - Stromversorgungsgruppe / Joint avec céramique - groupe d'alimentation / Junta con cerámica - grupo de alimentación
7	4D180201080	Disaccoppiatore coclea / disengaging device / Verängungsrohr / Tuyau de découplage / Desacoplador cóclea



**SABA 14**

Gruppo elettrico ed elettronico / Electrical and electronic group / Elektrische und elektronische Gruppe /  
Groupe électrique et électronique / Grupo eléctrico y electrónico

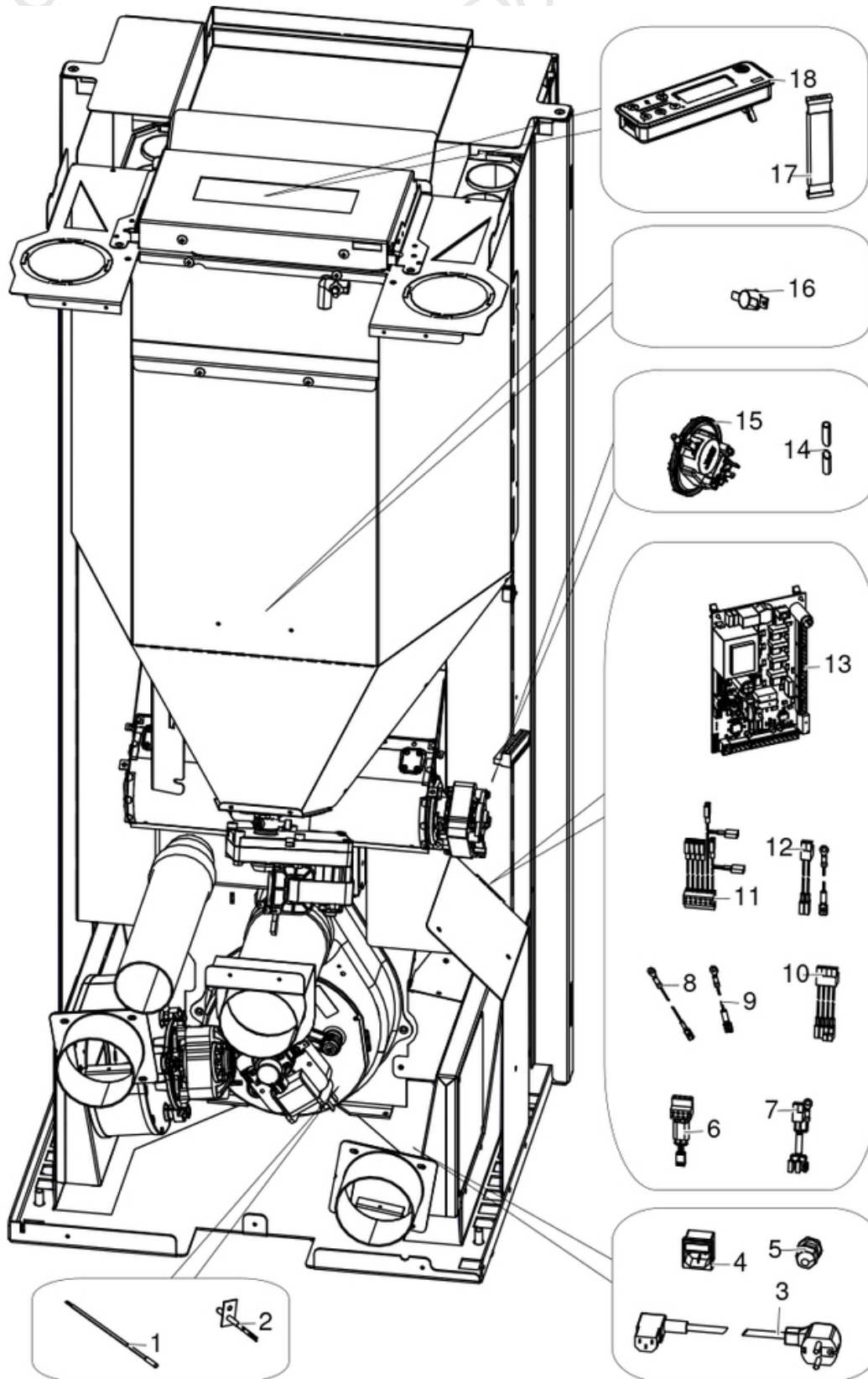

N°	Codice/Code	Descrizioni / Description / Beschreibung / Description / Descripción
1	4D145209070	Sonda ambiente / Room temperature sensor / Raumtemperaturfühler / Sonde température ambiante / Sonda ambiente
2	4D145209080	Sonda fumi / Smoke sensor / Rauchsonde / Sonde fumées / Sonda humos
3	4D14513041	Cavo alimentazione / Power source cable / Zündungskabel / Câble alimentation / Cable alimentación
4	4D14513084	Cavo con spina Shucko / Cable with Shucko plug / Kabel mit Schucko Steckdose / Cable avec fiche Shucko / Cable con enchufe Schucko
5	4D14513018	Pressacavo + cont. Dado / Cable holder / Kabelklemme / Presse-cable / Presionacable
6	4D145209120	Cavo encoder / Encoder cable / Encoder Kabel / Câble encoder / Cable encoder
7	4D145209100	Cablaggio ventilatori canalizzabile sx / wiring kit 2 Pin - left channel fans / Komplette Verkabelung 2 Pin Linkskanal-Fans / Câblage complet 2 Pin fans du canal gauche / Cableado completo 2 Pin fans del canal izquierdo
8	4D14513022	Cavo massa 680 mm / Mass cable 680 mm / Masse Kabel 680 mm / Cable masse 680 mm / Cable masa 680 mm
9	4D145184060	Cavo massa L.230 / Mass cable L.230 / Masse Kabel L.230 / Cable masse L.230 / Cable masa L.230
10	4D145209140	Cablaggio 4 pin completo / Complete wiring kit 4 Pin / Komplette Verkabelung 4 Pin / Câblage complet 4 Pin / Cableado completo 4 Pin
11	4D145209110	Cablaggio 6 pin completo / Wiring for left fan / Verkabelung für linken kanalisierbaren Luft Gebläse / Câblage pour ventilateur canalisable gauche / Cableado por ventilador canalizable IZQD
12	4D145209130	Cablaggio alimentazione scheda / Complete wiring for mother board power supply / Komplette Verkabelung für Platine Stromversorgung / Câblage complet pour alimentation carte / Cableado completo para alimentación tarjeta
13	4D1452002600	Scheda W003_A01 / Motherboard W003_A01 / Hauptplatine W003_A01 / Carte mère W003_A01 / Tarjeta madre W003_A01
14	4120631A	Tubicino silicónico - 5m / Silicon tube - 5m / Silikonrohr - 5m / Petit tuyau en silicone - 5m / Tubo silicónico - 5m
15	4D145181110	Pressostato / Pressure switch / Druckwächter / Pressostat / Presostato
16	4D14513006	Termostato 60°C / Thermostat 60°C / Thermostat 60°C / Thermostat 60°C / Termostato 60°C
17	4D145158020	Cavo flat scheda-pannello / Flat cable motherboard-control panel / Flat Kabel Hauptplatine-Bedienblende / Câble flat carte mère-panneau commande / Cable flat tarjeta madre-panel de mandos
18	4D1451303300	Pannello comandi grafico / Graphic control panel / Graphische Bedienblende / Tableau de commande / Panel de mandos gráfico

**SABA 14**

Gruppo aria comburente / Combustion air group / Verbrennungsluft Gruppe / Groupe air comburant / Grupo aire comburente

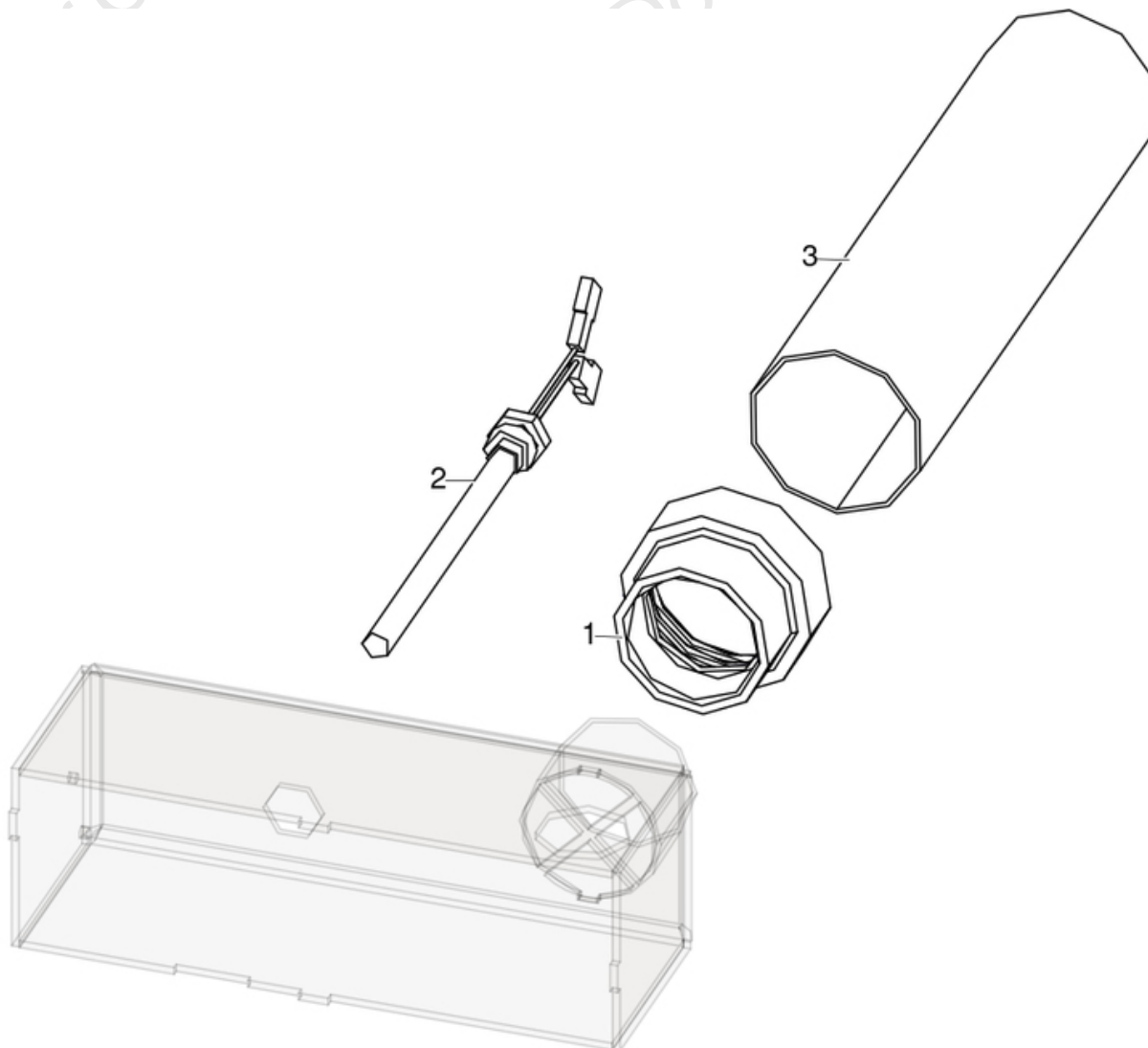

N°	Codice/Code	Descrizioni / Description / Beschreibung / Description / Descripción
1	4D180201080	Disaccoppiatore coclea / disengaging device / Verangungsrohr / Tuyau de d�couplage / Desacoplador c�clea
2	4D14513002	Candeletta / Sparkplug / Z�ndkerze Pelletz�ndung / Bougie / Buj�a encendido pellet
3	4D160209050	Tubo aria / Air pipe / Luftkanal / Conduit d'air / Tubo de aire

**SABA 14**

Gruppo ventilazione fino al SN 2105276010005 escluso / Ventilation group up to SN 2105276010005 excluded / Lüftungsgruppe bis zur SN 2105276010005 ausgeschlossen / Groupe ventilation jusqu'au NS 2105276010005 exclue / Grupo de Ventilación hasta NS 2105276010005 excluido

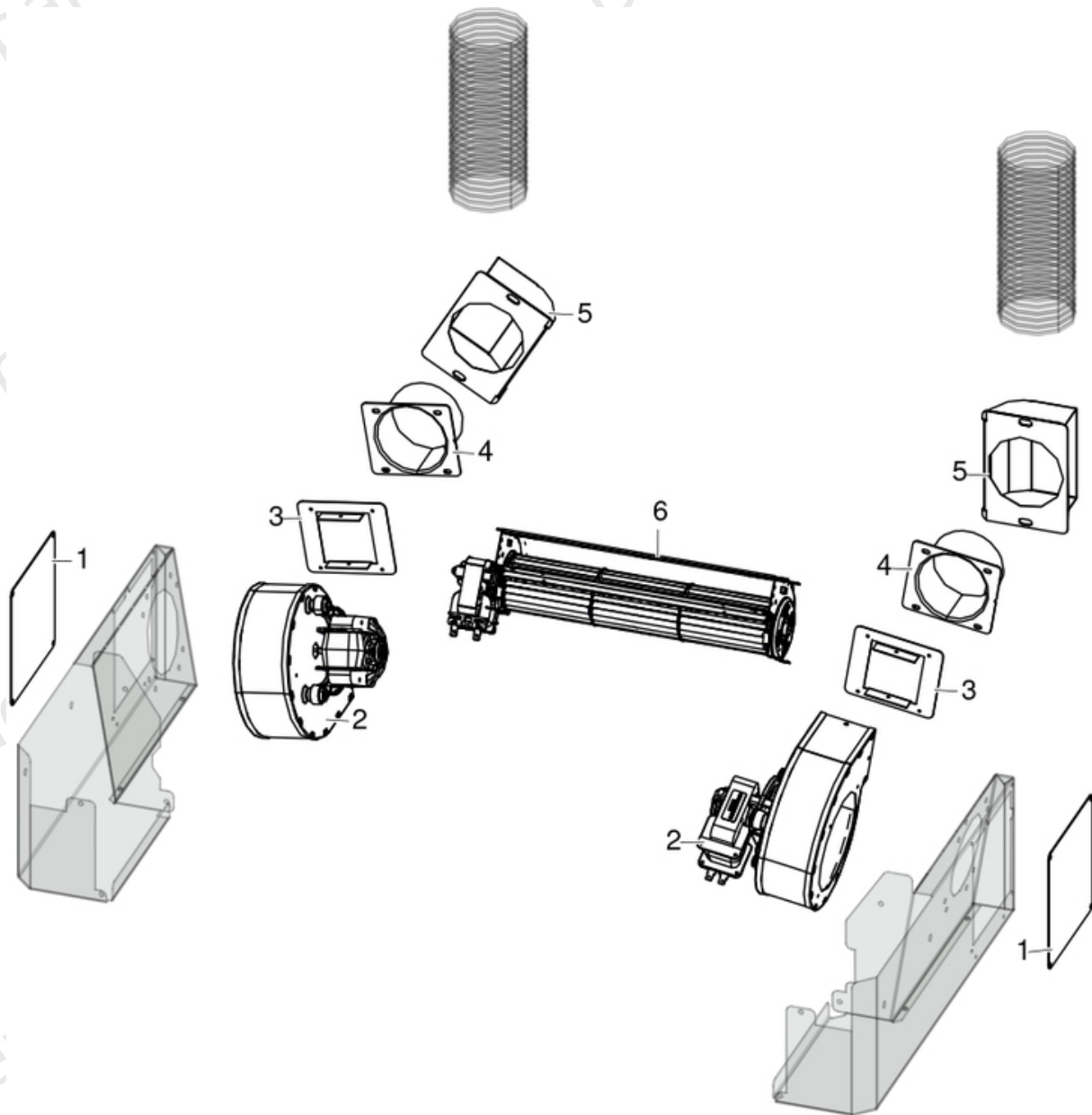

N°	Codice/Code	Descrizioni / Description / Beschreibung / Description / Descripcion
1	4D241209091	Tappo carter candeletta / Glow plug cover cap / Glühkerzendeckel / Couvercle de la bougie de préchauffage / Tapa de la tapa de bujía incandescente
2	4D145201070	Ventilatore aria / Air fan / Luftgebläse / Ventilateur air / Ventilador aire
3	4D241140083	Flangia / Flange / Flansche / Bride / Brida
4	4D14513040	Raccordo D.80 mm / Connector D.80 mm / Anschlußrohr D.80 mm / Raccord D.80 mm / Racor D.80 mm
5	4D24014023363	Diffusore aria calda / Hot air diffuser / Warmluftdiffusor / Diffuseur air chaude / Difusor aire caliente
6	4D145201010	Ventilatore / Fan / Luft Gebläse / Ventilateur air / Ventilador aire

**SABA 14**

Gruppo ventilazione dal SN 2105276010005 incluso / Ventilation group from SN 2105276010005 included / Lüftungsgruppe ab SN 2105276010005 eingeschlossen / Groupe ventilation à partir du NS 2105276010005 incluse / Grupo de Ventilación a partir de NS 2105276010005 incluido

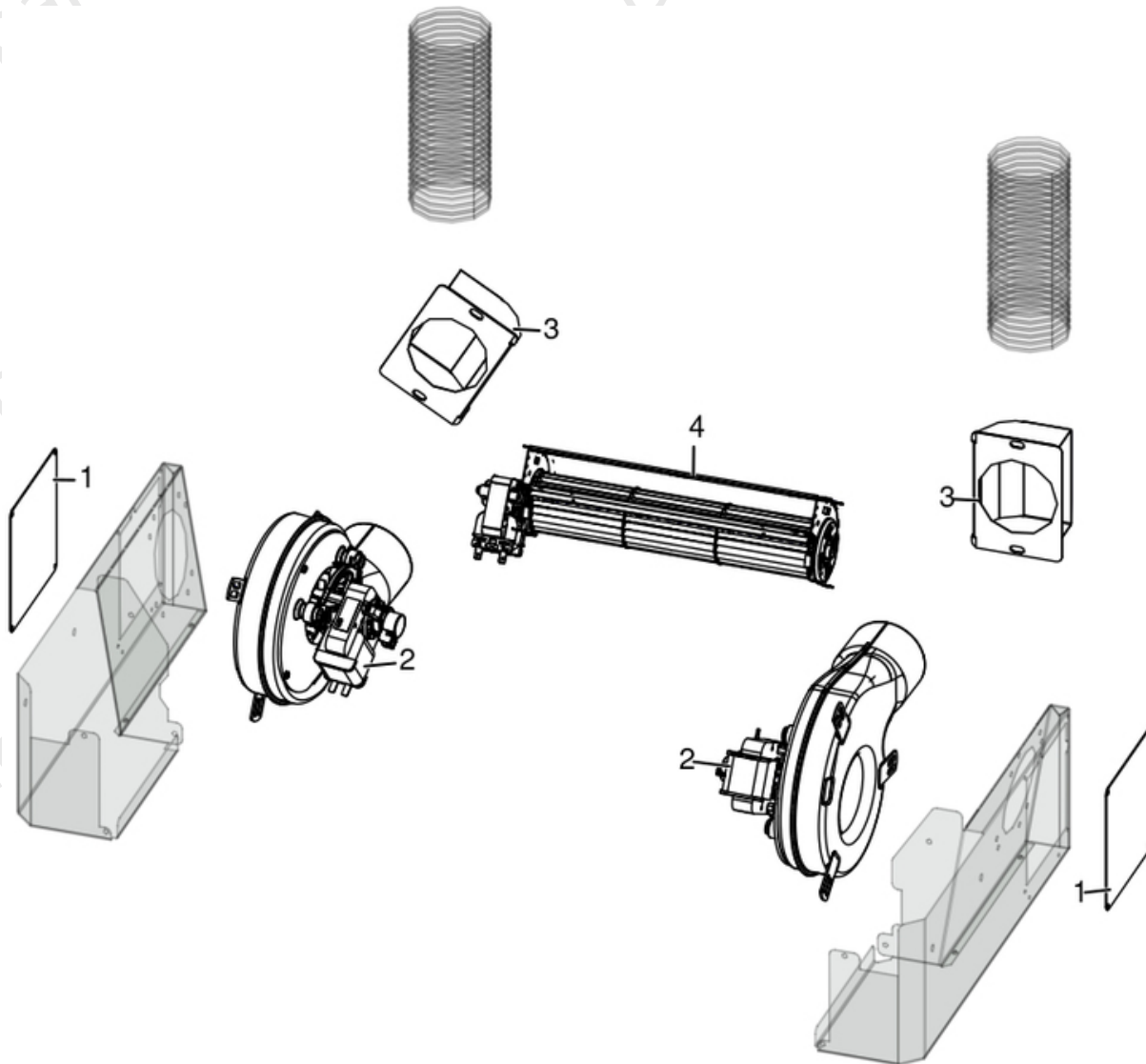

N°	Codice/Code	Descrizioni / Description / Beschreibung / Description / Descripción
1	4D241209091	Tappo carter candeletta / Glow plug cover cap / Glühkerzendeckel / Couvercle de la bougie de préchauffage / Tapa de la tapa de bujía incandescente
2	4D145209150	Ventilatore / Fan / Lüfter / Ventilateur / Ventilador
3	4D24014023363	Difusore aria calda / Hot air diffuser / Warmluftdiffusor / Diffuseur air chaude / Difusor aire caliente
4	4D145201010	Ventilatore / Fan / Luft Gebläse / Ventilateur air / Ventilador aire



**SABA 14**

Gruppo fumi / Smoke group / Rauchgruppe / Groupe fumées / Grupo de humos

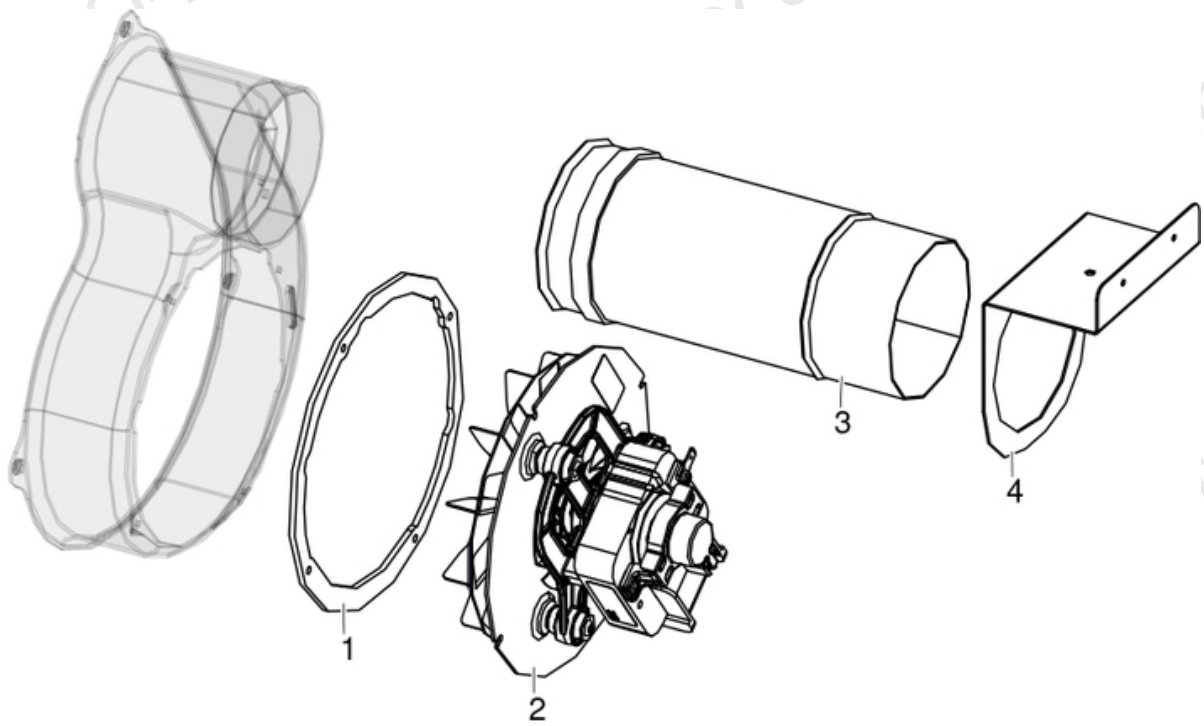

N°	Codice/Code	Descrizioni / Description / Beschreibung / Description / Descripción
1	41801600800	Guarnizione ventilatore fumi / Smoke exhaust fan gasket / Dichtung Rauchabsauggebläse / Joint Ventilateur aspiration fumées / Junta ventilador aspiración humos
2	4D145209020	Ventilatore fumi / Smoke exhaust fan / Rauchgasgebläse / Ventilateur aspiration fumées / Ventilador humos
3	4D16013022	Tubo D.80X192 mm / Pipe D.80X192 mm / Rohr D.80X192 mm / Tuyau D.80X192 mm / Tubo D.80X192 mm
4	4D241209143	Supporto tubo scarico fumi / Smoke exhaust pipe support / Abgasrohr Auslasshalterung / Support de sortie de conduit de fumée / Soporte para tubo de escape de humos