

SAGAR

Componenti Struttura Esterna / External structure components / Bauteile Aussenkorpus / Composants structure externe / Componentes estructura externa

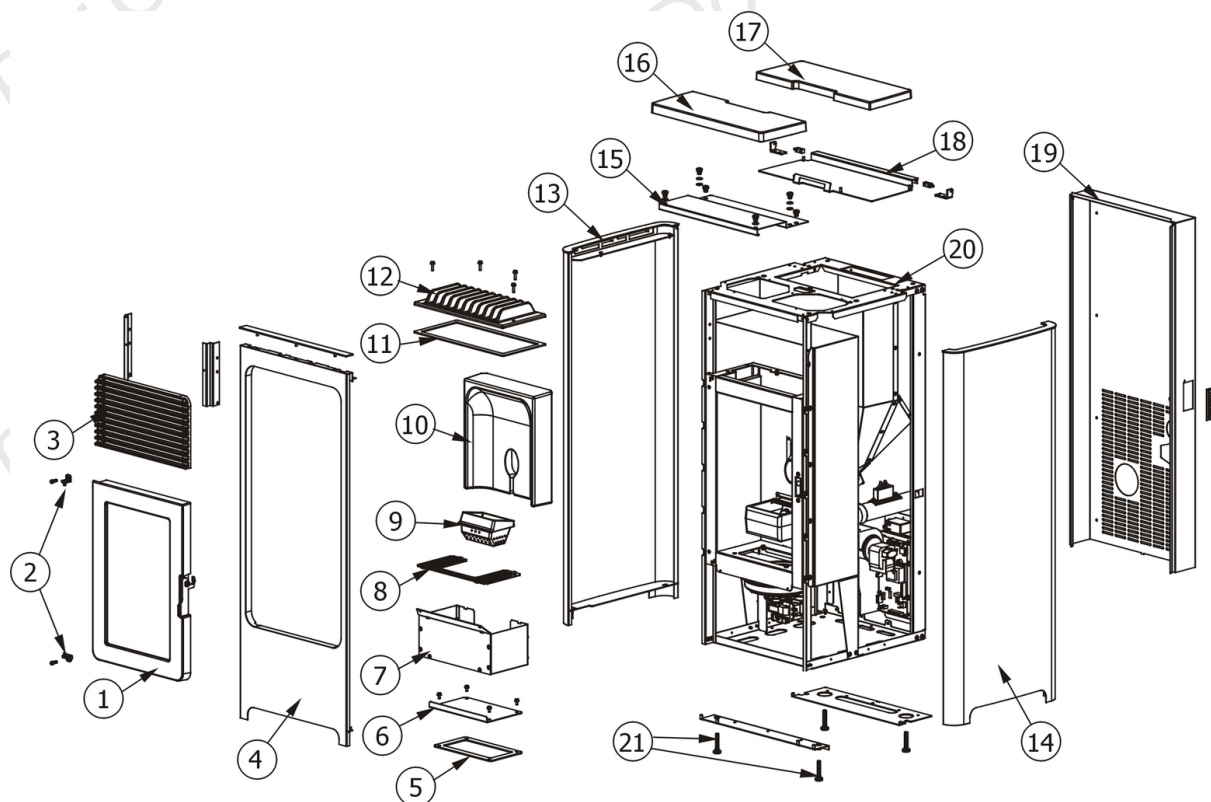

N°	Codice/Code	Descrizioni / Description / Beschreibung / Description / Descripción
1	41300901350	Porta finita completa / Complete door / Komplette Tür / Porte complète / Puerta completa
2	412008063	Cerniere porta fuoco (2 pz) / Fire door hinge (2pcs) / Scharnier Feuertür (2 Stck) / Charnière porte foyer (2 pcs) / bisagra puerta del hogar (2 pz)
3	41300901400V	Griglia uscita aria in ghisa / Cast iron air outlet grille / Gusseisenes Gitter Wärmeluftaustritt / Grille sortie air chaud en fonte / Rejilla salida aire en arrabio
4	41400940050	Frontale in acciaio nero / Frontal black steel panel / Fassade aus schwarze Stahl / Panneau frontal en acier noir / Panel frontal en acero negro
5	418008025	Guarnizione / Gasket / Dichtung / Joint / Junta
5	4180080251	Kit 50 guarnizioni / Kit 50 gaskets / Bausatz 50 Dichtungen / Kit 50 joints / Kit 50 juntas
6	41400906330V	Tappo ispezione vano fumi / Smoke compartment inspection plug / Inspektionsdeckel Rauchabzug / Clapet inspection compartiment fumées / Tapón inspección compartimento humos
7	41400906431V	Cassetto cenere / Ash drawer / Aschenkasten / Tiroir à cendres / Cajón ceniza
8	41400906610V	Griglia focolare / Fire box grille / Feuerstellenrost / Grille foyer / Rejilla hogar
9	413008003	Braciere completo in ghisa / Cast iron complete grate / Kompletter Brennerkopf aus Gusseisen / Brasero complet en fonte / Brasero completo de arrabio
10	43650151	Schiena in Alutec® / Alutec® back / Rückwand aus Alutec® / Fond en Alutec® / Parte trasera en Alutec®
11	41800802600	Kit 50 guarnizioni / Kit 50 gaskets / Bausatz 50 Dichtungen / Kit 50 joints / Kit 50 juntas
11	41800802601	Guarnizione / Gasket / Dichtung / Joint / Junta
12	41300901100	Scambiatore in ghisa / Cast iron exchanger / Gusseiserne Wärmetauscher / Echangeur en fonte / Intercambiador en arrabio
13	41400940750	Fianco acciaio Sx dark / L. dark steel side / Li. Stahlaussenseite Dark / Côté G. en acier dark / Lateral acero IZDO dark
14	41400940450	Fianco acciaio Dx dark / R. dark steel side / Re. Stahlaussenseite Dark / Côté D. en acier dark / Lateral DCHO en acero dark
15	41400941460	Supporto del top in ceramica / Support of ceramic top / Träger der Keramikabdeckplatte / Support du dessus en ceramic / Soporte del top en cerámica
16	41250907160	Top anteriore in ceramica white / Frontal white ceramic top / Vordere Keramikabdeckplatte White / Dessus antérieur

		en céramique white / Top anterior en cerámica white
16	41250909160	Top anteriore in ceramica White_Leaves / White_Leaver anterior ceramic top / Keramikabdeckplatte White_Leaves / Dessus en céramique White_Leaves / Top en cerámica White_Leaves
16	41250911000	Top in soapstone / Soapstone top / Abdeckplatte aus Soapstone / Dessus en soapstone / Top en soapstone
17	41250908150	Top posteriore in ceramica white (coperchio serbatoio pellet) / White rear ceramic top (Pellet hopper cover) / Hintere Keramikabdeckplatte White (Deckel Pelletbehälter) / Dessus posterieur en céramique white (Couvercle réservoir pellet) / Top posterior en cerámica white (Tapadera depósito pellet)
17	41250910150	Top posteriore in ceramica white_leaves (coperchio serbatoio pellet) / White_Leaves rear ceramic top (Pellet hopper cover) / Hintere Keramikabdeckplatte White_Leaves (Deckel Pelletbehälter) / Dessus posterieur en céramique white_leaves (Couvercle réservoir pellet) / Top posterior en cerámica white_leaves (Tapadera depósito pellas de madera)
17	41250911150	Top posteriore in soapstone (coperchio serbatoio pellet) / Rear soapstone top (Pellet hopper cover) / Hintere Keramikabdeckplatte aus Soapstone (Deckel Pelletbehälter) / Dessus posterieur en soapstone (Couvercle réservoir pellet) / Top posterior en soapstone (Tapadera depósito pellas de madera)
18	41400941360	Coperchio serbatoio pellet / Pellet hopper cover / Deckel Pelletbehälter / Couvercle réservoir pellet / Tapadera depósito pellet
19	41400941061	Schiena esterna in acciaio / Steel external back / Aussenrückwand aus Stahl / Fond extérieur en acier / Panel trasero externo en acero
20	41400904962	TOP in acciaio nero verniciato / Steel TOP painted black / ABDECKPLATTE in Stahl schwarz lackiert / DESSUS en acier laqué noir / TOP de acero negro barnizado
21	41200906660	Piedini di appoggio (4 pz.) / Support feet (4 pcs.) / Einstellfüße (4 Stck.) / Vérins d'appui (4 p.es) / Pies de apoyo (4 piezas)

SAGAR

Porta fuoco / Fire door / Feuertür / Porte foyer / Puerta hogar

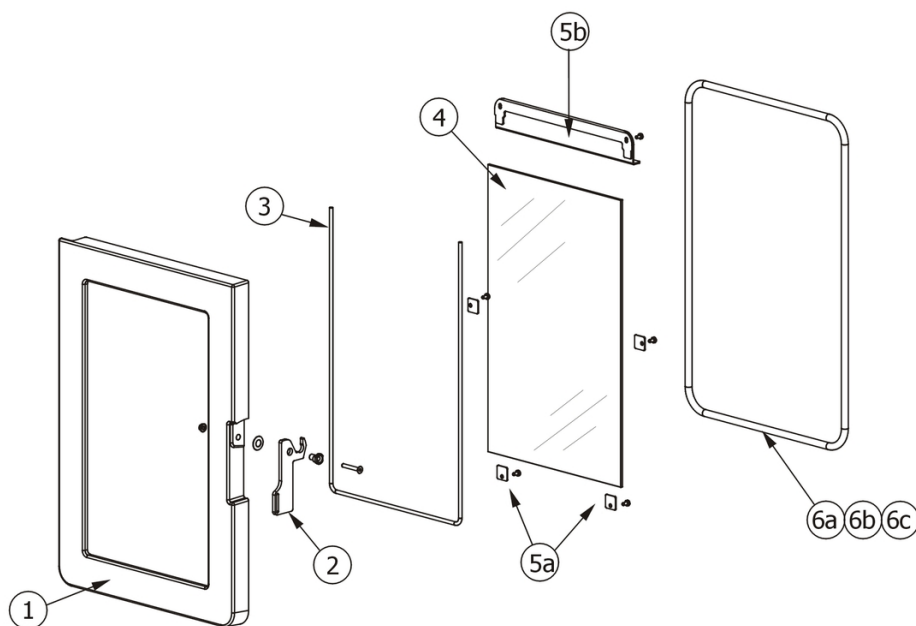

N°	Codice/Code	Descrizioni / Description / Beschreibung / Description / Descripción
1	41300901300V	Telaio porta in ghisa / Cast iron door frame / Türrahmen aus Gusseisen / Cadre porte en fonte / Marco puerta en arrabio
2	41400939760	Maniglia completa / Complete handle / Kompletter Griff / Poignée complète / Tirador completo
3	4120106	Guarnizione a nastro fireglass / Fireglass tape gasket / Banddichtung Fireglass / Joint ruban Fireglass / Guarnición a cinta Fireglass
4	41700901060	Vetroceramico completo di guarnizione / Glass with gasket / Glaskeramikscheibe mit Dichtung / Vitrocéramique avec joint / Cristal cerámico con guarnición
5a	41401077430	Staffe di fissaggio vetroceramico (4 pz.) / Pyroceram fastening brackets (4 pcs.) / Befestigungsbügel Glaskeramik (4 Stck.) / Étrier de fixation vitrocéramique (4 pz.) / Abrazaderas de fijación vidrio cerámico (4 piezas)
5b	41400939630V	Deflettore porta / Door deflector / Leitblech der Tür / Déflecteur de la porte / Deflector de la puerta
6a	4120103A	Cordino fibroceramico Ø 10 mm (5 mt.) / Ceramic fibre cord Ø 10 mm (5 m) / Keramikfaserschnur Ø 10 mm (5 m) / Cordon en fibre céramique Ø 10 mm (5 m) / Junta a cuerda de fibra cerámica Ø 10 mm (5 m)
6b	4120103B	Cordino fibroceramico Ø 10 mm (50 mt.) / Ceramic fibre cord Ø 10 mm (50 m) / Keramikfaserschnur Ø 10 mm (50 m) / Cordon en fibre céramique Ø 10 mm (50 m) / Junta a cuerda de fibra cerámica Ø 10 mm (50 m)
6c	41201031	Kit sostituzione cordino (cordino+silicone) Ø 10 mm / Cord replacement kit (cord + silicone) Ø 10 mm / Schnuraustauschsatz (Schnur+Silikon) Ø 10 mm / Kit remplacement cordon (cordon + silicone) Ø 10 mm / Kit sustitución junta a cuerda (junta a cuerda+silicón) Ø 10 mm

SAGAR

Componenti interni meccanici ed elettronici / Electronic and mechanic internal parts / Interne mechanische und elektronische Bauteile / Composants internes mécaniques et électroniques / Componentes internos electrónicos y mecánicos

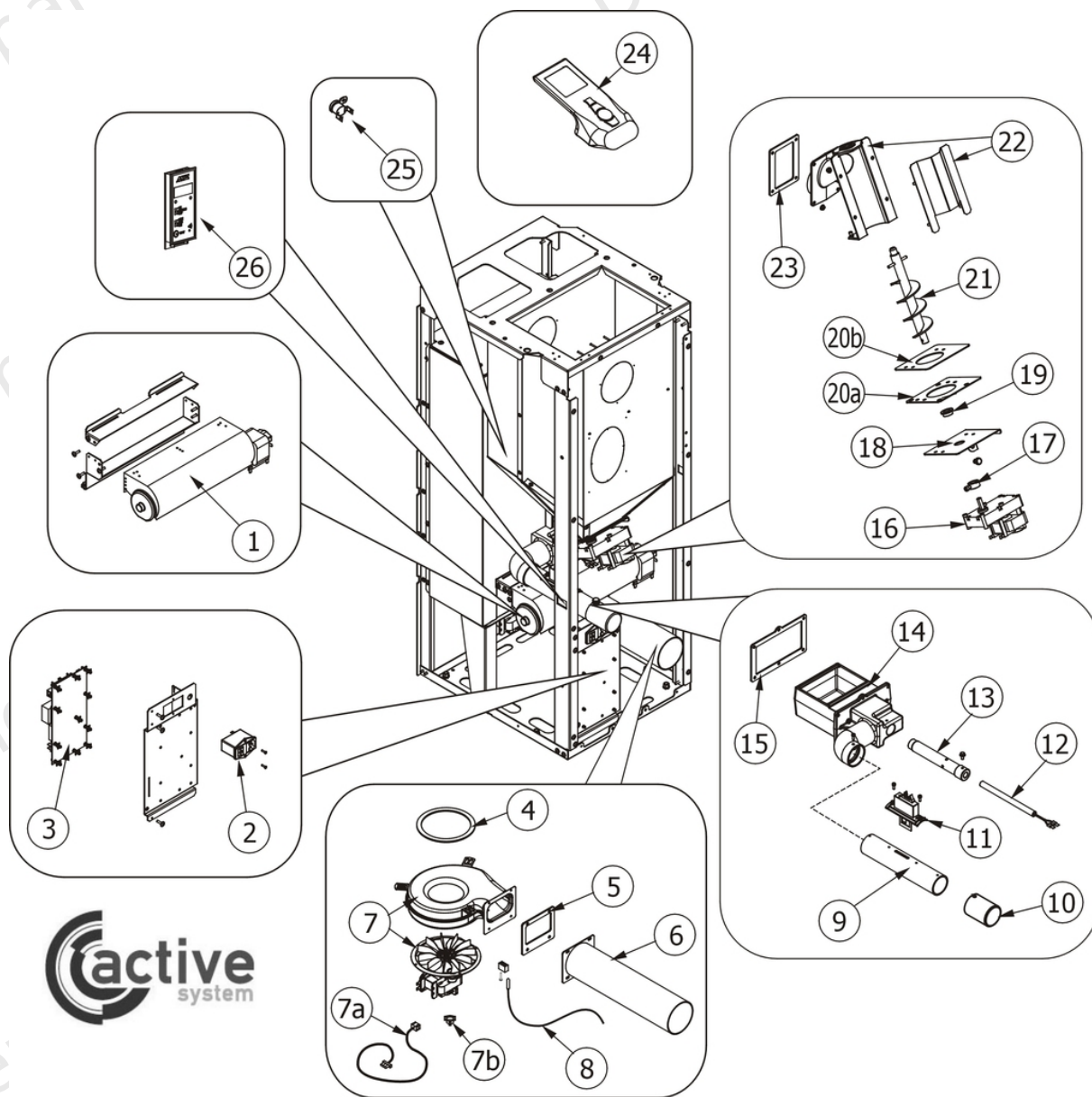

N°	Codice/Code	Descrizioni / Description / Beschreibung / Description / Description
1	41451002800	Ventilatore aria calda / Warm air fan / Warmluftgebläse / Ventilateur air chaud / Ventilador aire caliente
2	4160459	Pulsante accensione / On/Off button / Zündungstaste / Touche d'allumage / Botón encendido
3	41450907601	Scheda madre CEZA / Motherboard CEZA / Hauptplatine CEZA / Carte mère CEZA / Tarjeta madre CEZA
3	41801499750	Kit 868 / Kit 868 / Kit 868 / Kit 868 / Kit 868
4	41801002600	Guarnizione adesiva voluta fumi / Adhesive gasket smoke volute / Haftendichtung Rauchvolute / Joint adhesive volute fumées / Junta adhesiva voluta humos
4	41801599850	Kit 50 guarnizioni / Kit 50 gaskets / Bausatz 50 Dichtungen / Kit 50 joints / Kit 50 juntas
5	418008030	Guarnizione / Gasket / Dichtung / Joint / Junta
6	416008010	Tubo uscita fumi / Smoke outlet pipe / Rohr Rauchabzug / Tuyau sortie fumées / Tubo salida humos
7	41451003202	Ventilatore aspirazione fumi / Smoke exhausted fan / Rauchabsauggebläse / Ventilateur aspiration fumées / Ventilador aspiración humos
7	41801102500	Guarnizione / Gasket / Dichtung / Joint / Junta

7a	4160477	Cavo ENCODER / ENCODER cable / Drehzahlmesser-kabel / Câble ENCODER / Cable ENCODER
7b	41451209300	Encoder per ventilatore fumi marchi LN2/SIT / Encoder for LN2/SIT smoke fan / Encoder für LN2/SIT Rauchgasgebläse / Encoder pour ventilateur des fumées marques LN2/SIT / Encoder para ventilador humos marcas LN2/SIT
8	41450901800	Sonda fumi Active System / Smoke sensor Active System / Rauchgasfühler ACTIVE SYSTEM / Sonde fumées ACTIVE SYSTEM / Sonda humos Active System
9	41200901200	Tubo ingresso aria / Air inlet pipe / Luftergangrohr / Tuyau entrée air / Tubo entrada aire
10	41401036100	Filtro antipolvere / Anti-dust filter / Staubschutzfilter / Filtre antipoussière / Filtro de protección polvo
11	41451205000	Sensore aria completo / Complete air sensor / Kompletter Luftfühler / Capteur air complet / Sensor aire completo
12	41450905000	Candeletta accensione pellet / Pellet ignition sparkplug / Zündkerze Pelletzündung / Bougie d'allumage pellet / Bujía encendido pellet
12	41801599550	Kit 50 candelette / 50 Sparkplugs kit / Bausatz 50 Zündkerzen / Kit 50 Bougies / Kit 50 Bujías
13	41200903900	Condotto candeletta / Sparkplug conduit / Zündkerzenkanal / Conduit bougie / Conducto bujía
14	414008043	Tasca braciere in ghisa / Combustion pot container / Brenntopfkasten aus Gusseisen / Récipient braséro / Contenedor brasero
14	41401069141V	Tasca braciere / Combustion pot container / Brenntopfkasten / Récipient braséro / Contenedor brasero
15	418008027	Guarnizione / Gasket / Dichtung / Joint / Junta
16	4160278	Motoriduttore 1,5 RPM / Reduction motor 1,5 RPM / Getriebemotor 1,5 RPM / Motorréducteur 1,5 TPM / Motorreductor 1,5 RPM
17	4120398	Connettore motoriduttore-coclea / Reduction motor-feed screw connector / Verbindung Getriebemotor-Schnecke / Connecteur motorréducteur-vis sans fin / Conector motorreductor-cóclea
18	41400944351	Base della coclea / Feed screw base / Untergestell der Förderschnecke / Base de la vis sans fin / Base de la cóclea
19	4120614	Boccola grafitata (2 pz) / Etched bush (2 pcs) / Graphitbuchse (2 Stck) / Bride graphitée (2 pcs) / Brida grafitada (2 pz)
20a	4120615	Guarnizione base della coclea / Feed screw base gasket / Dichtung Untergestell der Förderschnecke / Joint pour la base de la vis sans fin / Junta base de la cóclea
20b	41400903310	Flangia condotto coclea / Base of feed screw conduit / Untergestell Rohrleitung der Förderschnecke / Base du conduit de la vis sans fin / Base de conducto de la cóclea
21	41200901040	Coclea di caricamento pellet / Pellet feed screw / Pelletsförderschnecke / Vis sans fin pour chargement du pellet / Cóclea de carga pellet
22	41401077540V	Condotto della coclea / Conduit of feed screw / Rohrleitung der Förderschnecke / Conduit de la vis sans fin / Conducto de la cóclea
24	41450901500	Telecomando / Remote control / Fernbedienung / Télécommande / Mando a distancia
24	41451106000	Telecomando / Remote control / Fernbedienung / Télécommande / Mando a distancia
24	41801499750	Kit 868 / Kit 868 / Kit 868 / Kit 868 / Kit 868
24	41451301203	Telecomando nero 434,5MHZ - Funzione impostabile da 0 a 3 Ventilatori / Black remote control 434,5MHZ - From 0 to 3 fan function / Schwarze Fernbedienung 434,5MHZ - Von 0 bis 3-Gebläse-Steuerung / Télécommande noire 434,5MHZ - Fonctionne à partir de 0 à 3 Ventilateurs / Mando a distancia negro 434,5MHZ - Función de 0 a 3 ventiladores
23	418008029	Guarnizione / Gasket / Dichtung / Joint / Junta
25	412007004	Clickson 110°C / Clickson 110°C / Clickson 110°C / Clickson 110°C / Clickson 110°C
26	41450900700	Pannello di emergenza / Emergency panel / Notfalldisplay / Tableau de secours / Panel d'emergencia
26	41450902500	Cavo flat / Flat cable / Flat-Kabel / Cable flat / Cable flat
26	41801499750	Kit 868 / Kit 868 / Kit 868 / Kit 868 / Kit 868