

MALVA MULTIAIR - EASY CONNECT

Componenti Struttura Esterna / External structure components / Bauteile Aussenkorpus / Composants structure externe / Componentes estructura externa

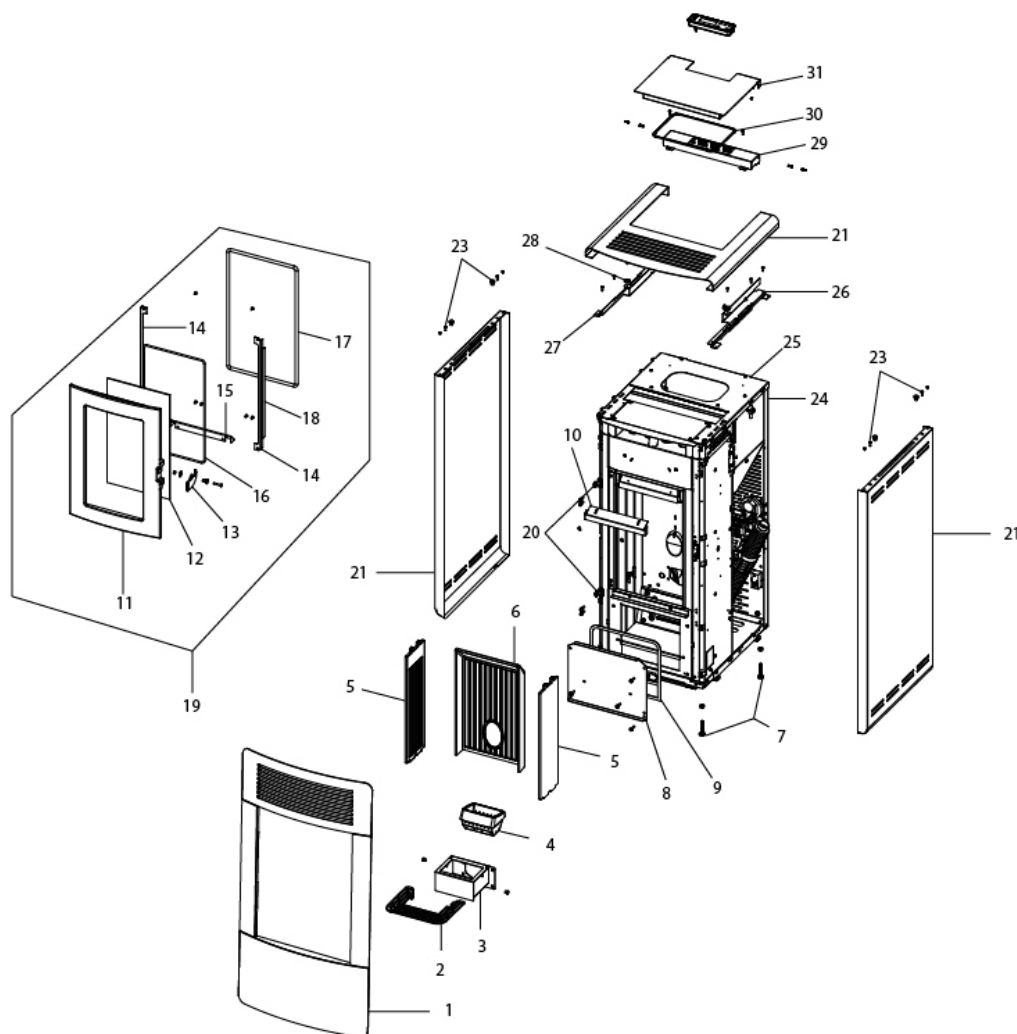

N°	Codice/Code	Descrizioni / Description / Beschreibung / Description / Descripcion
1	41421700741P	Assieme frontale / Front panels / Vordere Paneele / Panneaux frontaux / Paneles frontales
2	41411634830V	Griglia focolare / Fire Box Grille / Feuerstellenrost / Grille Foyer / Rejilla Hogar
3	41402071340	Tasca braciere / Combustion pot container / Brenntopfkasten / Récipient brasero / Contenedor brasero
4	41301502400V	Braciere ghisa / Cast iron grate / Brennertopf aus Gusseisen / Brasero en fonte / Brasero en arrabio
5	41301502700V	Fianco ghisa / Cast iron side / Seite aus Guß / Côté en fonte / Placa lateral de arrabio
5	41301502700V	Fianco ghisa / Cast iron side / Seite aus Guß / Côté en fonte / Placa lateral de arrabio
6	41301502800V	Schiena ghisa nera / Cast iron back / Rückwand aus Gusseisen / Dosseret en fonte / Parte trasera en arrabio
7	41200906660	Piedini di appoggio (4 pz.) / Support feet (4 pcs.) / Einstellfüße (4 Stck.) / Vérins d'appui (4 p.es) / Pies de apoyo (4 piezas)
7	41200906660	Piedini di appoggio (4 pz.) / Support feet (4 pcs.) / Einstellfüße (4 Stck.) / Vérins d'appui (4 p.es) / Pies de apoyo (4 piezas)
8	437016050	Tappo inferiore / Lower cover / Untere Abdeckung / Couvercle inférieur / Tapón inferior
9	4120573A	Guarnizione a nastro 8 mm (5 mt.) per porta / Door strip gasket 8 mm (5 m) / Türbanddichtung 8 mm (5 m) / Joint ruban 8 mm (5 m) pour porte / Guarnición de cinta para puerta 8 mm (5 m)
9	4120573B	Guarnizione a nastro 8 mm (50 mt.) per porta / Door strip gasket 8 mm (50 m) / Türbanddichtung 8 mm (50 m) / Joint ruban 8 mm (50 m) pour porte / Guarnición de cinta para puerta 8 mm (50 m)

10	41411615430V	Deflettore aria / Air deflector / Luftleitblech / Déflecteur aire / Deflector aire
10	41151600200	Deflettore focolare in vermiculite / Vermiculite deflector / Leitblech aus Vermiculite / Déflecteur en vermiculite / Deflector en vermiculite
11	41301600400V	Porta fuoco in ghisa / Cast iron fire door / Feuertür aus Guß / Porte foyer en fonte / Puerta hogar de arrabio
12	41701600300	Vetroceramica porta ghisa / Cast iron door glass / Glaskeramikscheibe Tür aus Gusseise / Vitrocéremique porte en fonte / Cristal cerámico puerta en arrabio
13	41401424160	Maniglia completa / Complete handle / Kompletter Griff / Poignée complète / Tirador completo
14	41411622030V	Profilo fermavetro / Fastening bracket profile / Haltebügel für Scheibebefestigung Profil / Profil patte de fixation / Perfil fermacristal
14	41411622030V	Profilo fermavetro / Fastening bracket profile / Haltebügel für Scheibebefestigung Profil / Profil patte de fixation / Perfil fermacristal
15	41411622130V	Scivolo cenere / Ash ramp / Aschenrutsche / Glissèrie cendre / Tobogán ceniza
16	41801603300A	Guarnizione Ø5 5mt / Gasket Ø5 5mt / Dichtung Ø5 5mt / Joint Ø5 5mt / Junta Ø5 5mt
16	41801603300B	Guarnizione Ø5 50mt / Gasket Ø5 50mt / Dichtung Ø5 50mt / Joint Ø5 50mt / Junta Ø5 50mt
16	41801603300C	Guarnizione Ø5 5mt + silicone / Gasket Ø5 5mt + silic / Dichtung Ø5 5mt + Silikon / Joint Ø5 5mt + silic / Junta Ø5 5mt
17	4120103A	Cordino fibroceramico Ø 10 mm (5 mt.) / Ceramic fibre cord Ø 10 mm (5 m) / Keramikfaserschnur Ø 10 mm (5 m) / Cordon en fibre céramique Ø 10 mm (5 m) / Junta a cuerda de fibra cerámica Ø 10 mm (5 m)
17	4120103B	Cordino fibroceramico Ø 10 mm (50 mt.) / Ceramic fibre cord Ø 10 mm (50 m) / Keramikfaserschnur Ø 10 mm (50 m) / Cordon en fibre céramique Ø 10 mm (50 m) / Junta a cuerda de fibra cerámica Ø 10 mm (50 m)
17	41201031	Kit sostituzione cordino (cordino+silicone) Ø 10 mm / Cord replacement kit (cord + silicon) Ø 10 mm / Schnur austauschsatz (Schnur+Silikon) Ø 10 mm / Kit remplacement cordon (cordon + silicone) Ø 10 mm / Kit sustitución junta a cuerda (junta a cuerda+silicón) Ø 10 mm
18	4120573A	Guarnizione a nastro 8 mm (5 mt.) per porta / Door strip gasket 8 mm (5 m) / Türbanddichtung 8 mm (5 m) / Joint ruban 8 mm (5 m) pour porte / Guarnición de cinta para puerta 8 mm (5 m)
18	4120573B	Guarnizione a nastro 8 mm (50 mt.) per porta / Door strip gasket 8 mm (50 m) / Türbanddichtung 8 mm (50 m) / Joint ruban 8 mm (50 m) pour porte / Guarnición de cinta para puerta 8 mm (50 m)
19	437016193	Porta completa / Complete door / Komplette Tür / Porte complète / Puerta completa
20	41201504460	Cerniera porta (2 pz.) / Door hinge (2 pc.) / Tür Scharnier (2 Stk.) / Charnière porte (2 pc.) / Bisagra puerta (2)
20	41201504460	Cerniera porta (2 pz.) / Door hinge (2 pc.) / Tür Scharnier (2 Stk.) / Charnière porte (2 pc.) / Bisagra puerta (2)
21	6917001	Rivestimento Metal Black / Metal Black cladding / Verkleidung Metal Black / Habillage Metal Black / Revestimiento Metal Black
21	6917002	Rivestimento Metal Bordeaux / Metal Bordeaux cladding / Verkleidung Metal Bordeaux / Habillage pMetal Bordeaux / Revestimiento Metal Bordeaux
21	6917003	Rivestimento Metal White / Metal White cladding / Verkleidung Metal White / Habillage Metal White / Revestimiento Metal White
21	6917004	Rivestimento Metal Silver / Metal Silver cladding / Verkleidung Metal Silver / Habillage Metal Silver / Revestimiento Metal Silver
21	6917001	Rivestimento Metal Black / Metal Black cladding / Verkleidung Metal Black / Habillage Metal Black / Revestimiento Metal Black
21	6917002	Rivestimento Metal Bordeaux / Metal Bordeaux cladding / Verkleidung Metal Bordeaux / Habillage pMetal Bordeaux / Revestimiento Metal Bordeaux
21	6917003	Rivestimento Metal White / Metal White cladding / Verkleidung Metal White / Habillage Metal White / Revestimiento Metal White
21	6917004	Rivestimento Metal Silver / Metal Silver cladding / Verkleidung Metal Silver / Habillage Metal Silver / Revestimiento Metal Silver
21	6917001	Rivestimento Metal Black / Metal Black cladding / Verkleidung Metal Black / Habillage Metal Black / Revestimiento Metal Black
21	6917002	Rivestimento Metal Bordeaux / Metal Bordeaux cladding / Verkleidung Metal Bordeaux / Habillage pMetal Bordeaux / Revestimiento Metal Bordeaux
21	6917003	Rivestimento Metal White / Metal White cladding / Verkleidung Metal White / Habillage Metal White / Revestimiento Metal White
21	6917004	Rivestimento Metal Silver / Metal Silver cladding / Verkleidung Metal Silver / Habillage Metal Silver / Revestimiento Metal Silver
23	41801002300	Paracolpi in silicone Ø 8/5 (2pz) / Silicone bumpers Ø 8/5 (2pcs) / Schlagschutzgummi Ø 8/5 (2 Stck) / Pièces silicone antichoc Ø 8/5 (2pcs) / Anti-golpes en silicona Ø 8/5 (2pzs)
23	41801002300	Paracolpi in silicone Ø 8/5 (2pz) / Silicone bumpers Ø 8/5 (2pcs) / Schlagschutzgummi Ø 8/5 (2 Stck) / Pièces silicone antichoc Ø 8/5 (2pcs) / Anti-golpes en silicona Ø 8/5 (2pzs)
24	41401628332	Schiena posteriore / Rear back / Hintere Rückwand / Dossieret postérieur / Parte trasera
25	41411703731V	Supporto top / Top support / Deckelhaltebügel / Support du dessus / Soporte del top

26	41411703831V	Staffa alta DX / RH side support bracket / Rechte Seitenhaltebügel / Etier G. support coté / Estribo IZDO soporte lado
27	41411703931V	Staffa alta SX / LH side support bracket / Linke Seitenhaltebügel / Etier D. support coté / Estribo DCHA soporte lado
28	41801657900	Magneti (pz.2) / Magnet (pcs.2) / Magnet (stk. 2) / Aimant (pcs.2) / Imán (pz.2)
29	41411668930P	Supporto pannello comandi / Control panel support / Haltebügel für Bedienblende / Support pannea de commandes / Soporte panel de mandos
30	41801504700	Guarnizione tenuta serbatoio / Pellet hopper gasket / Pelletbehälter Dichtung / Joint réservoir pellet / Junta depósito pellet
31	41411669041P	Coperchio completo serbatoio / Complete hopper cover / Komplet Deckel Pelletbehälter / Couvercle réservoir complét / Tapa depósito completa

MALVA MULTIAIR - EASY CONNECT

Componenti interni meccanici ed elettronici / Electronic and mechanic internal parts / Interne mechanische und elektronische Bauteile / Composants internes mécaniques et électroniques / Componentes internos electrónicos y mecánicos

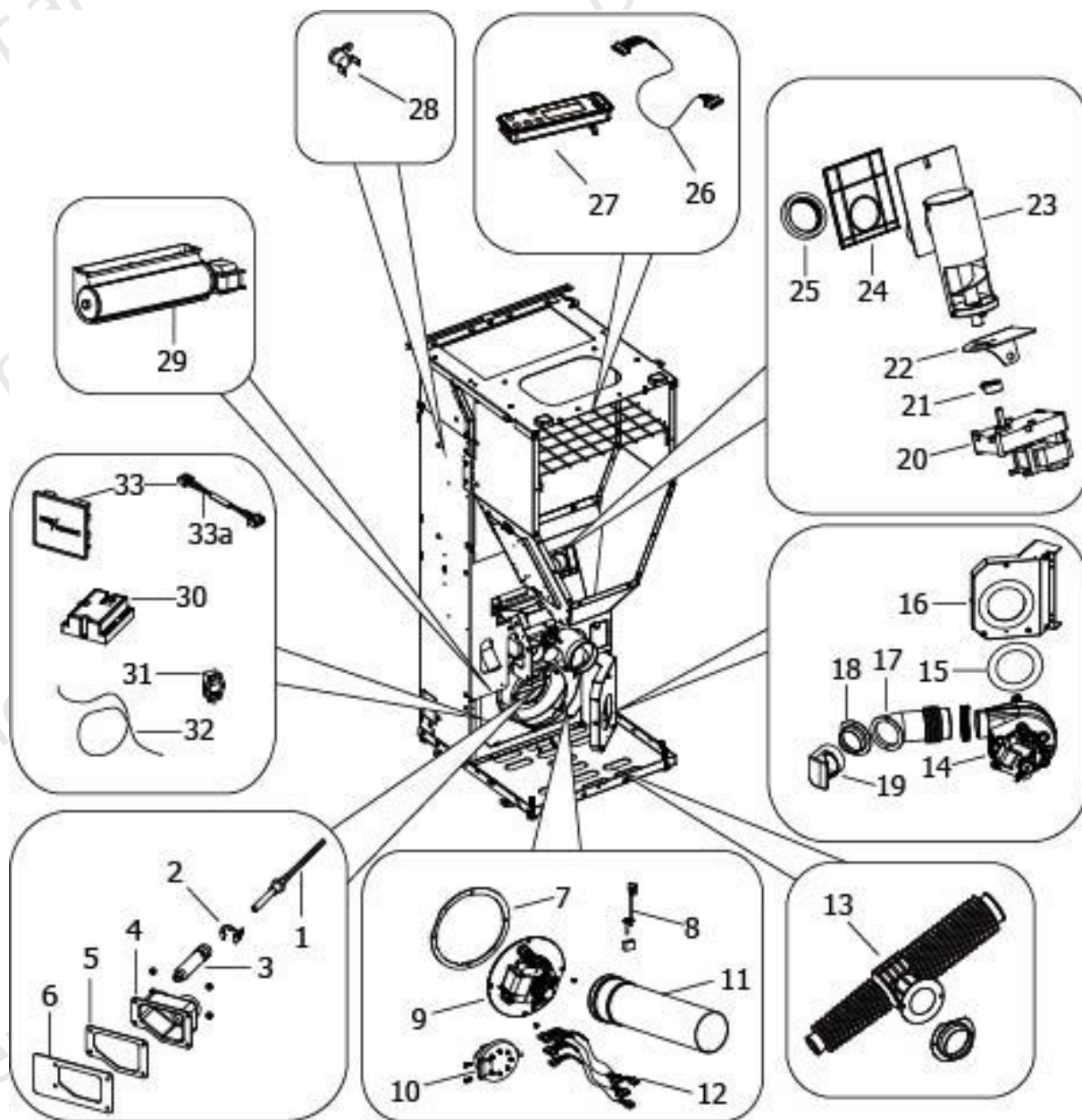

N°	Codice/Code	Descrizioni / Description / Beschreibung / Description / Description
1	41451308101	Candelella 315 Watt / Sparkplug 315 Watt / Zündkerze 315 Watt / Bougie 315 Watt / Bujía 315 Watt
1	41501701599	Manicotto potenziamento accensione / Combustion air extension pipe / Zusatzrohr für Nachrüstung / Tuyau amélioration allumage / Tubo impulso de encendido
2	41201601500	Anello arresto candelella / Sparkplug stop / Zündkerzestopper / Butée bougie / Tope bujía
3	41601601000	Condotto candelella / Sparkplug Conduit / Zündkerzenkanal / Conduit Bougie / Conducto Bujía
3	41501701599	Manicotto potenziamento accensione / Combustion air extension pipe / Zusatzrohr für Nachrüstung / Tuyau amélioration allumage / Tubo impulso de encendido
4	41311803500	Codolo / Tool chuck / Einspannschaft / Outil d'emmanchement / Mango
5	41801602300	Guarnizione codolo / Gasket / Dichtung / Joint / Junta
6	41801601500	Guarnizione tasca braciere / Combustion pot container gasket / Brenntopfkasten Dichtung / Joint récipient brasero / Junta contenedor brasero

7	41801600800	Guarnizione ventilatore fumi / Smoke exhaust fan gasket / Dichtung Rauchabsauggebläse / Joint Ventilateur aspiration fumées / Junta ventilador aspiración humos
8	41451002300	Sonda fumi con flangia / Smoke sensor with flange / Rauchgasfühler mit Flansche / Sonde fumées avec bride / Sonda humos con arandela
9	41451503200	Ventilatore fumi stagno / Air-tight smoke fan / Luftdichtes Rauchgasgebläse / Ventilateur fumées étanche / Ventilador humos hermético
10	41451003700	Pressostato / Pressure switch / Druckschalter / Pressostat / Presostato
11	41601604560	Tubo fumi Ø 80 con guarnizione / Smoke pipe Ø 80 with gasket / Rauchrohr Ø 80 mit Dichtung / Tuyau fumées Ø 80 avec joint / Tubo humos Ø 80 con junta
12	41451603600	Cablaggio elettrico / Electrical wiring / Elektrische Verkabelung / Câblage électrique / Cableado eléctrico
13	41801605200	Tubo siliconico con flangia diffusore aria / Silicone pipe with flange diffuser air / Silikonrohr mit Flansch diffuser Luft / Tuyau en silicone avec bride air diffusant / Tubo silicónico con arandela difusor aire
14	41451503300	Ventilatore centrifugo / Air fan / Lufgebläse / Ventilateur air / Ventilador aire
15	41801601600	Guarnizione ventilatore / Fan gasket / Dichtung des Gebläses / Joint du ventilateur / Junta ventilador
16	41401624731	Convogliatore C/Air / Conveyor C/Air / Blech C/Air / Convoyeur C/Air / Conductor C/Air
17	41801601100	Tubo uscita aria silicone / Outlet air tube in silicone / Luftausgangrohr aus Silikon / Tuyau de sortie air en silicone / Tubo de salida aire en silicona
18	41600900460	Flangia Ø 60 / Flange Ø 60 / Flansch Ø 60 / Bride Ø 60 / Brida Ø 60
19	41801605300	Bocchetta posteriore in silicone / Silicone rear air outlet / Luftauslass aus Silikon / Diffuseur air en silicone / Boquilla aire en silicona
20	41451503100	Motoriduttore 2rpm / Gear motor 2rpm / Getriebemotor 2rpm / Motoréducteur 2rpm / Motorreductor 2rpm
21	4120398	Connettore motoriduttore-coclea / Reduction motor-feed screw connector / Verbindung Getriebemotor-Schnecke / Connecteur motoréducteur-vis sans fin / Conector motorreductor-cóclea
22	41401623830	base coclea pellet / Feed screw base for pellet / Untergestell der Förderschnecke für Pellet / Base de la vis sans fin granulés / Base de la cóclea pellets
23	41402002050	Gruppo alimentazione / Complete feed screw / Komplette Förderschnecke / Vis sans fin complète / Coclea de carga completa
24	41802000300	Guarnizione / Gasket / Dichtung / Joint / Junta
25	41801702600	Guarnizione / Gasket / Dichtung / Joint / Junta
26	4160414	Cavo Rond-Flat / Round-Flat cable / Round-Flat Kabel / Rond-Flat Câble / Cable Rond-Flat
27	41451200600	Pannello comandi / Control panel / Bedienblende / Panneau de commande / Panel de mandos
28	412007004	Clickson 110°C / Clickson 110°C / Clickson 110°C / Clickson 110°C / Clickson 110°C
29	41451600800	Ventilatore aria / Air fan / Luftgebläse / Ventilateur air / Ventilador aire
30	41452004400	Scheda madre W003+PQ055_A01 - non programmata MICRONOVA / Unprogrammed motherboard W003+PQ055_A01 MICRONOVA / Unprogrammerte Hauptplatine W003+PQ055_A01 MICRONOVA / Carte mère W003+PQ055_A01 - Non programmée MICRONOVA / Tarjeta madre W003+PQ055_A01 - sin programa MICRONOVA
30	41452004400A	Scheda W003+PQ055_A01 - FW OYSTER AIR MICRONOVA / Motherboard W003+PQ055_A01 - FW OYSTER AIR MICRONOVA / Hauptplatine W003+PQ055_A01 - FW OYSTER AIR MICRONOVA / Carte mère W003+PQ055_A01 - FW OYSTER AIR MICRONOVA / Tarjeta madre W003+PQ055_A01 - FW OYSTER AIR MICRONOVA
31	41451104100	Presca con fusibile / Socket with fuse / Steckdose mit Sicherung / Prise avec fusible / Toma con fisible
32	4160386	Sonda temperatura ambiente/acqua / Room/Water temperature sensor / Raum- Wassertemperaturfühler / Sonde température ambiente/eau / Sonda temperatura ambiente/agua
33	4020003	Wi-Fi Easy Connect / Wi-Fi Easy Connect / Wi-Fi Easy Connect / Wi-Fi Easy Connect / Wi-Fi Easy Connect
33a	41452002500	Cavo flat / Flat cable / Flat-Kabel / Cable flat / Flat cable