

MCZ GROUP

DOC COMFORT AIR 9 UP! M1

Gruppo estetico / Aesthetic group / Aesthetische Gruppe / Groupe esthétique / Grupo estético

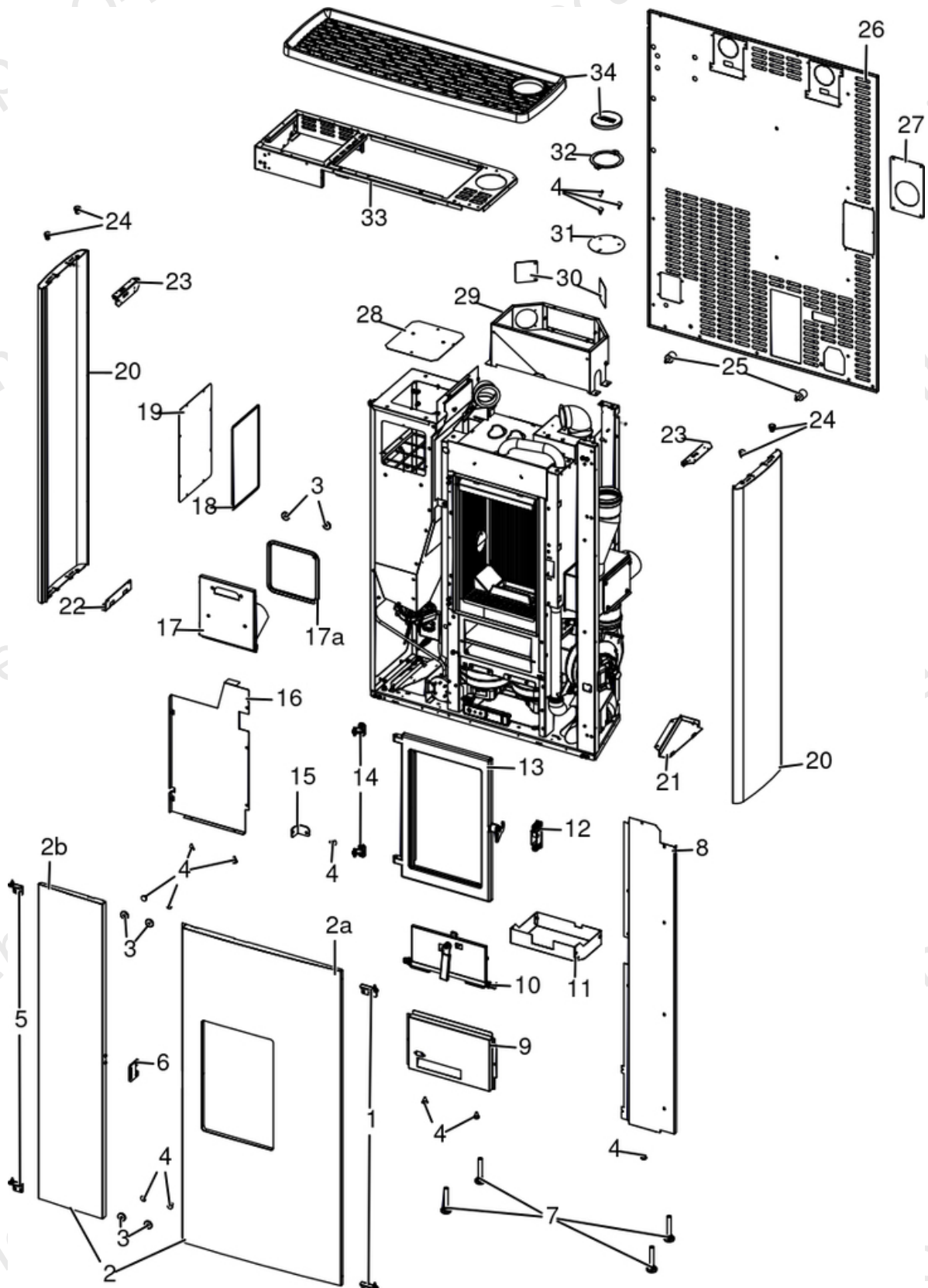

N°	Codice/Code	Descrizioni / Description / Beschreibung / Description / Descripcion
1	41411750240V	Cerniere porta frontale (2 pz) / Hinges frontal door (2 pcs) / Scharniere vordere Tür (2 Stk) / Charnières porte frontale (2 pcs) / Bisagra puerta frontal (2 pz)
2	41801904050	Porta frontale e di caricamento / Frontal and loading door / Front- und Einfüllungstür / Porte frontale et de chargement / Puerta frontal y de carga
2a	41411749540P	Porta frontale completa / Complete frontal door / Komplette Fronttür / Porte frontale complète / Puerta frontale completa
2b	41411748850	Porta caricamento pellet completa / Pellet loading door / Tür Pelleteinfüllung / Porte de chargement des pellets / Puerta de carga pellet
3	41801657900	Magneti (pz.2) / Magnet (pcs.2) / Magnet (stk. 2) / Aimant (pcs.2) / Imán (pz.2)
4	41801002300	Paracolpi in silicone Ø 8/5 (2pz) / Silicone bumpers Ø 8/5 (2pcs) / Schlagschutzgummi Ø 8/5 (2 Stck) / Pièces silicone antichoc Ø 8/5 (2pcs) / Anti-golpes en silicona Ø 8/5 (2pzs)
5	41411749440V	Cerniere porta caricamento (2 pz) / Hinges loading door (2 pcs) / Scharniere Pelleteinfüllung Tür (2 Stk) / Charnières porte chargement (2 pcs) / Bisagra puerta de carga (2 pz)
6	41411744460	Maniglia porta esterna / External door handle / Außentür Griff / Poignée porte extérieur / Tirador puerta exterior
7	41200906660	Piedini di appoggio (4 pz.) / Support feet (4 pcs.) / Einstellfüße (4 Stck.) / Vérins d'appui (4 p.es) / Pies de apoyo (4 piezas)
8	4141174873000	Tamponazione laterale DX / R. lateral filling / Seitliche Abdichtung R. / Tampon lateral D. / Tamponado lateral DRCH
9	4141174334000	Tamponazione centrale inferiore / Lower central filling / Untere zentrale Abdichtung / Tampon centrale inférieur / Taponado centrale inferior
10	437018248	Porta cenere / Ash door / Aschentür / Porte de cendres / Puerta ceniza
11	41401713931	Cassetto cenere / Ash drawer / Aschenkasten / Tiroir à cendres / Cajón ceniza
12	41411599950	Kit serratura ammortizzato / Pressur relief kit / Bausatz Überdruckablauf Brennkammer / Kit deocompression chambre comcusion / Kit decompression cámara combustion
13	437017119	Porta focolare / Fireplace door / Feuerstelle Tür / Porte foyer / Puerta hogar
14	41201504460	Cerniera porta (2 pz.) / Door hinge (2 pc.) / Tür Scharnier (2 Stk.) / Charnière porte (2 pc.) / Bisagra puerta (2)
15	41411742730V	Blocco porta focolare / Stop for Fireplace door / Stopper für Feuerstelle Tür / Stop pour porte foyer / Tope por puerta hogar
16	4141174863000	Tamponazione SX / L. filling / Abdichtung L. / Tampon G. / Tamponado IZQD
17	41411748550	Coperchio tecnico / Technical cover / Technicher Deckel / Couvercle technique / Tapadera técnica
17a	41801604700	Guarnizione tenuta serbatoio / Pellet hopper gasket / Pelletbehälter Dichtung / Joint réservoir pellet / Junta depósito pellet
18	4120572A	Guarnizione a nastro 6 mm (5 mt.) per porta / Door strip gasket 6 mm (5 m) / Türbanddichtung 6 mm (5 m) / Joint ruban 6 mm (5 m) pour porte / Guarnición de cinta para puerta 6 mm (5 m)
18	4120572B	Guarnizione a nastro 6 mm (50 mt.) per porta / Door strip gasket 6 mm (50 m) / Türbanddichtung 6 mm (50 m) / Joint ruban 6 mm (50 m) pour porte / Guarnición de cinta para puerta 6 mm (50 m)
19	41401713410	Tappo posteriore serbatoio / Rear hopper cover / Hintere Deckel Behälter / Couvercle postérieur réservoir / Tapa posterior depósito
20	41411750340P	Fianco destro/sinistro / Right/left side / Rechte/Linke Seite / Coté droit/gauche / Lateral DCHO/IZQDO
21	41401715630	Staffa supporto fianco destro / Right side support bracket / Rechte Seitenhaltebügel / Etrier support coté droite / Estructo soporte lado derecho
22	41401715730	Staffa supporto fianco sinistro / Left side support bracket / Linke Seitenhaltebügel / Etrier support coté gauche / Estructo soporte lado izquierdo
23	41401907130	Staffa fissaggio fianchi / Sides fixing bracket / Haltebügel für Seite / Étrier fixation cotés / Abrazadera fijacion flanco
24	4120180	Gommini paracolpi (4 pz) / Rubber bumpers (4 pcs.) / Schlagschutzgummi (4 Stck) / Pièces caoutchouc antichoc (4 pcs) / Cauchitos anti-golpes (4 pz)
25	41201105600	Antivibranti (10 pz) / anti-vibration mountings (10 pcs) / Schwingungsdämpfer (10 Stck) / Éléments antivibratoires (10 pcs) / Anti-vibraciones (10 pz)
26	41401716030	Schienna esterna posteriore / External rear back / Hintere Rückwand / Dossieret postérieur extérieur / Parte trasera
27	41401823110	Flangia / Flange / Flansch / Bride / Brida
28	4140171451100	Tappo serbatoio / Hopper cover / Verschluss Pelletbehälter / Bouchon réservoir / Tapa depósito
29	41411748350	Convogliatore / Air duct / Förder / Convoyeur / Conductor
30	4140171401000	Tappo convogliatore / Air duct cover / Förderveschluss / Bouchon convoyeur / Tapa conductor
31	41401715910	Supporto tappo ghisa / Cast iron top support / Stöpselhalterung aus Guß / Support du bouchon en fonte / Supporte tapa en arrabio
32	4141183651000	Flangia / Flange / Flansch / Bride / Brida
33	4141184473000	Supporto top / Top support / Deckelhaltebügel / Support du dessus / Soporte del top

34	6917015	Top Black metal_303 / Top Black metal_303 / Top Black metal_303 / Top Black metal_303 / Top Black metal_303
34	6917016	Top Aluminuim metal_315 / Top Aluminuim metal_315 / Top Aluminuim metal_315 / Top Aluminuim metal_315 / Top Aluminuim metal_315
34	41801701400	Logo MCZ / MCZ logo / MCZ logo / MCZ logo / MCZ logo

DOC COMFORT AIR 9 UP! M1

Gruppo camera di combustione / Combustion chamber group / Verbrennungskammer Gruppe / Group de chambre de combustion / Grupo cámara de combustión

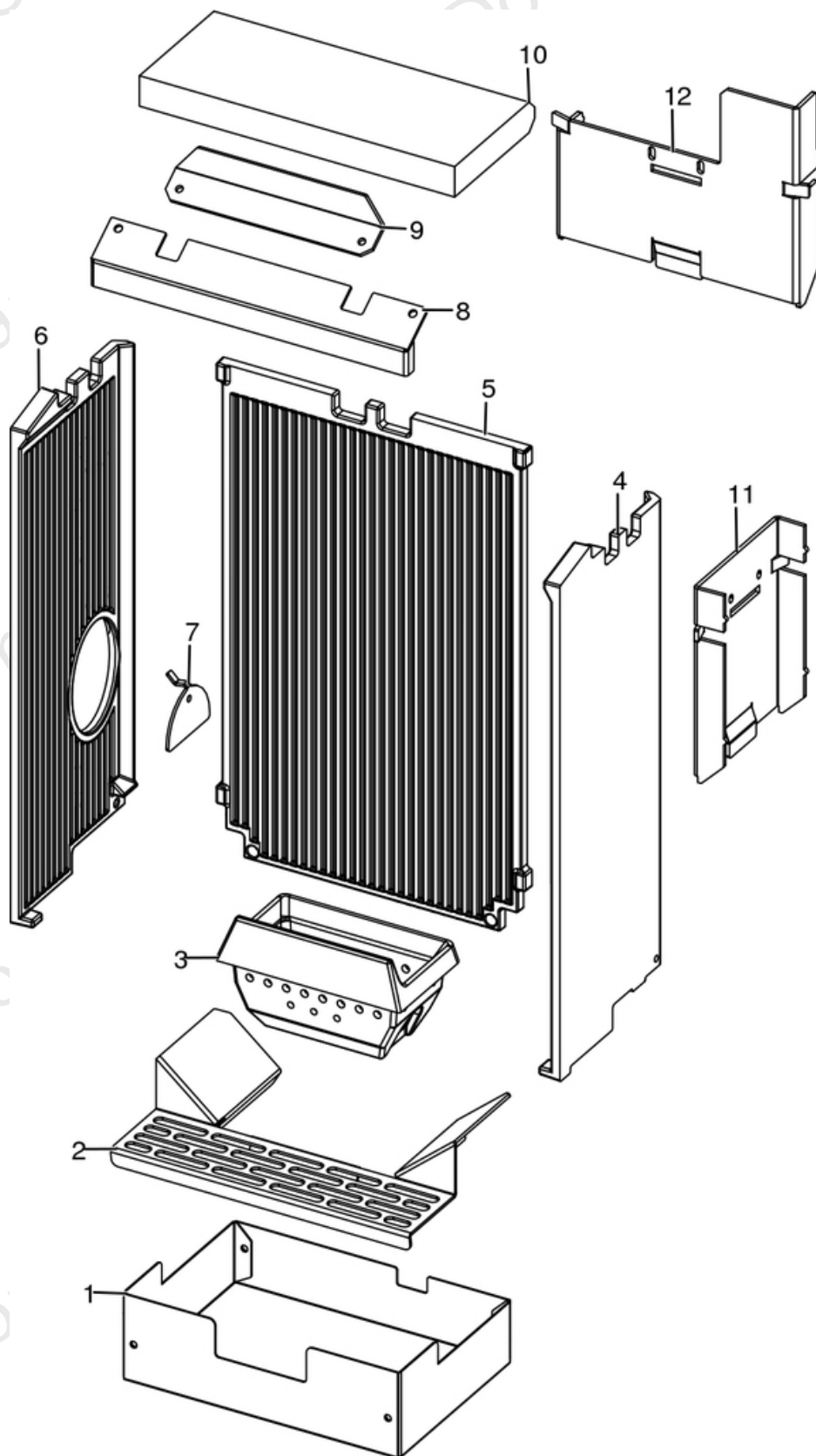

N°	Codice/Code	Descrizioni / Description / Beschreibung / Description / Descripcion
1	41401713930	Cassetto cenere / Ash drawer / Aschenkasten / Tiroir à cendres / Cajón ceniza
2	41411742230V	Griglia focolare / Fire box grille / Feuerstellenrost / Grille foyer / Rejilla hogar
3	4130170030100	Braciere ghisa / Cast iron brazier / Brennschale aus Guß / Brasero en fonte / Brasero de arrabio
4	41301700500V	Fianco destro in ghisa nero / Black right cast iron side / Rechte Seite aus Guß schwarz / Coté droit en fonte noir / Placa lateral derecha de arrabio negro
5	41301700700V	Schiena in ghisa nero / Black cast iron back / Rückwand aus Guß schwarz / Fond en fonte noir / Parte trasera de arrabio negro
6	41301700600V	Fianco sinistro in ghisa nera / Black L. side / Aussenseite L. schwarz / Côté G. noir / Lateral IZDO negro
7	41411613530V	Deflettore pellet / Pellet deflector / Pellet Leitblech / Deflecteur pellet / Deflector pellet
8	41401854430	Deflettore pulizia vetro / Glass deflector / Leitblech der Scheibe / Déflecteur de la vitre / Deflector del cristal
9	41331702031	Protezione focolare inox / Inox fire protection / Feuerschutz aus Edelstahl / Protection foyer inox / Protección hogar inox
10	41151702000	Deflettore vermiculite / Vermiculite deflector / Leitblech aus Vermiculite / Déflecteur en vermiculite / Deflector en vermiculite
11	41411740231	Tappo lat. pulizia struttura / Lateral cap for structure cleaning / Seitlicher Stöpsel für Korpus Reinigung / Bouchon lateral pour nettoyage structure / Tapon lateral por limpieza estructura
12	41411740131	Tappo post. pulizia struttura / Rear cap for structure cleaning / Hinterer Stöpsel für Korpus Reinigung / Bouchon posterieur pour nettoyage structure / Tapon posterior por limpieza estructura

DOC COMFORT AIR 9 UP! M1

Porta fuoco / Fire door / Feuertür / Porte foyer / Puerta hogar

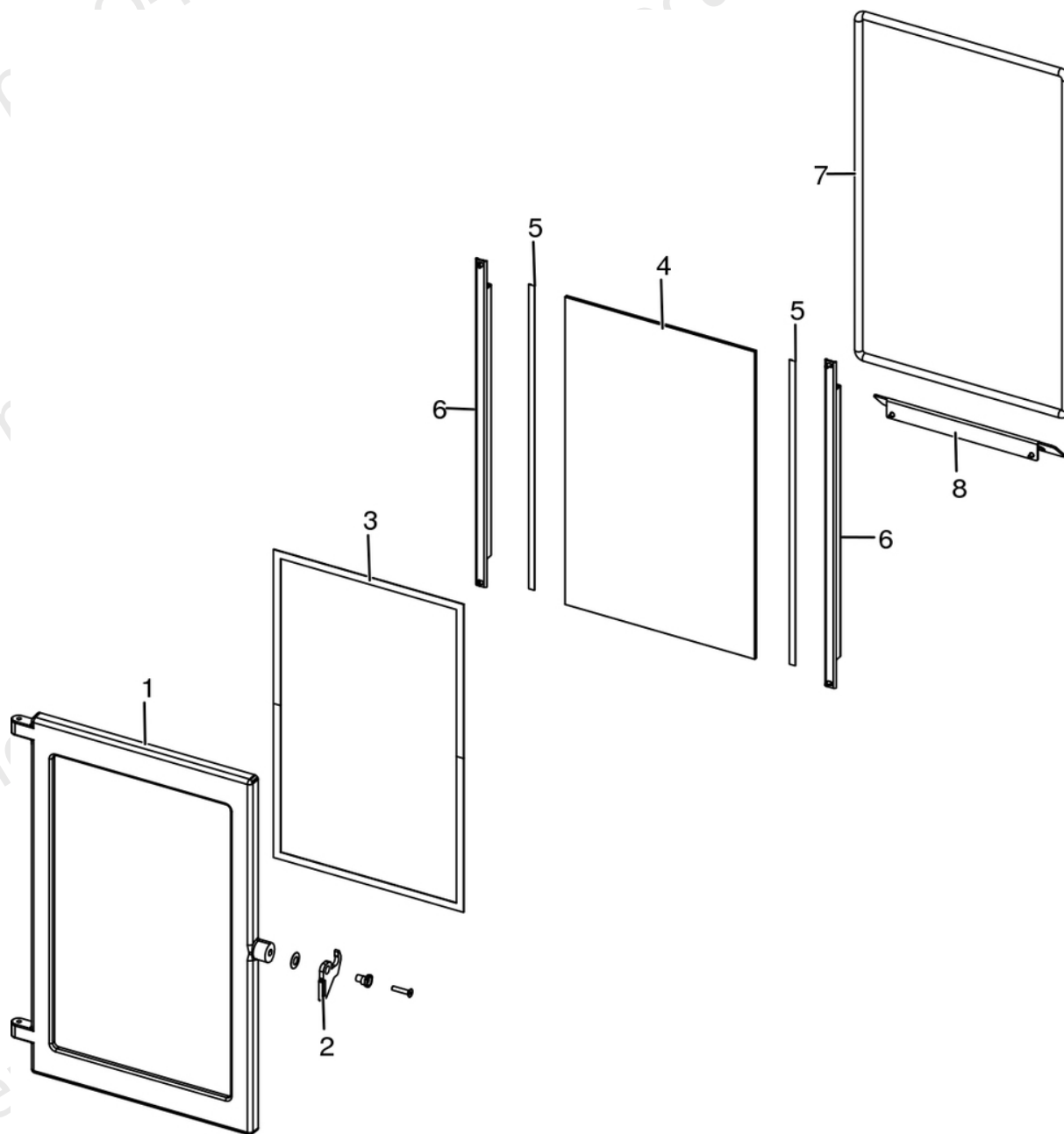

N°	Codice/Code	Descrizioni / Description / Beschreibung / Description / Descripción
1	41301700400V	Porta focolare ghisa / Cast iron fire door / Feuertür aus Guß / Porte foyer en fonte / Puerta hogar de arrabio
2	41411742161	Maniglia porta focolare / Fire door handle / Feuertür Griff / Poignée porte foyer / Tirador puerta fuego
3	41801603300A	Guarnizione Ø5 5mt / Gasket Ø5 5mt / Dichtung Ø5 5mt / Joint Ø5 5mt / Junta Ø5 5mt
3	41801603300B	Guarnizione Ø5 50mt / Gasket Ø5 50mt / Dichtung Ø5 50mt / Joint Ø5 50mt / Junta Ø5 50mt
3	41801603300C	Guarnizione Ø5 5mt + silicone / Gasket Ø5 5mt + silic / Dichtung Ø5 5mt + Silikon / Joint Ø5 5mt + silic / Junta Ø5 5mt
4	41701701800	Vetroceramico porta tecnica / Technical door glass / Glas für technische Tür / Vitrocéramique porte technique / Cristal cerámico puerta técnica
5	4120573A	Guarnizione a nastro 8 mm (5 mt.) per porta / Door strip gasket 8 mm (5 m) / Türbanddichtung 8 mm (5 m) / Joint ruban 8 mm (5 m) pour porte / Guarnición de cinta para puerta 8 mm (5 m)
5	4120573B	Guarnizione a nastro 8 mm (50 mt.) per porta / Door strip gasket 8 mm (50 m) / Türbanddichtung 8 mm (50 m) / Joint ruban 8 mm (50 m) pour porte / Guarnición de cinta para puerta 8 mm (50 m)

6	4160170440000	Profilo fermavetro / Fastening bracket profile / Haltebügel für Scheibebefestigung Profil / Profil patte de fixation / Perfil fermacristal
7	4120104A	Cordino fibroceramico Ø 12 mm (5 mt.) / Ceramic fibre cord Ø 12 mm (5 m.) / Keramikfaserschnur Ø 12 mm (5 m) / Cordon en fibre céramique Ø 12 mm (5 m) / Junta a cuerda de fibra cerámica Ø 12 mm (5 m)
7	4120104B	Cordino fibroceramico Ø 12 mm (50 mt.) / Ceramic fibre cord Ø 12 mm (50 m.) / Keramikfaserschnur Ø 12 mm (50 m) / Cordon en fibre céramique Ø 12 mm (50 m) / Junta a cuerda de fibra cerámica Ø 10 mm (52 m)
7	41201041	Kit sostituzione cordino (cordino+silicone) Ø 12 mm / Cord replacement kit (cord + silicon) Ø 12 mm / Schnuraustauschsatz (Schnur+Silikon) Ø 12 mm / Kit remplacement cordon (cordon + silicone) Ø 12 mm / Kit sustitución junta a cuerda (junta a cuerda+silicón) Ø 12 mm
8	4141174203100	Scivolo cenere / Ash ramp / Aschenrutsche / Glissière cendre / Tobogán ceniza

DOC COMFORT AIR 9 UP! M1

Gruppo caricamento pellet / Pellet feed group / Pellet Fördergruppe / Groupe chargement du pellet / Grupo de carga pellet

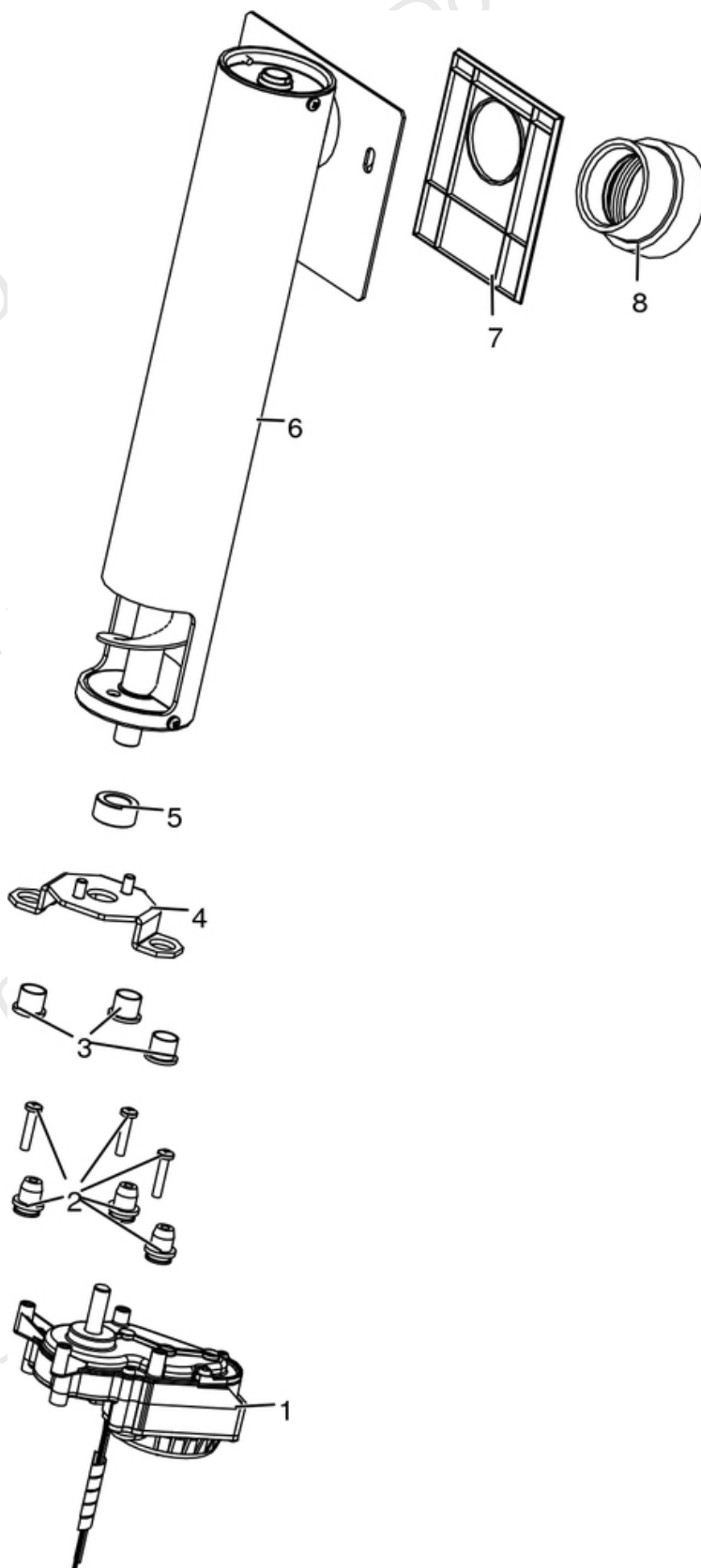

N°	Codice/Code	Descrizioni / Description / Beschreibung / Description / Descripción
1	41451702200	Motoriduttore brushless / Brushless reduction motor / Brushless Getriebemotor / Motoréducteur brushless / Motorreductor brushless
2	41801703700	Gommini antivibrante / Vibration damper rubber / Rammschutz Gummi / Caoutchouc antivibratoire / Cauchitos antivibración
3	41201800700	Boccola (3 pz) / Bushing (3 pcs) / Buchse (3 Stk) / Douille (3 pcs) / Abrazadera (3 pzs)
4	41411779331	Supporto coclea "Ragno" / Pellet feed screw bracket "spider" / "Spinne" Schenke Gestell / Support vis sans fin "Araignée" / Soporte coclea "Araña"
5	4120398	Connettore motoriduttore-coclea / Reduction motor-feed screw connector / Verbindung Getriebemotor-Schnecke / Connecteur motoréducteur-vis sans fin / Conector motorreductor-cóclea
6	41411741151	Alimentazione completa / Complete power / Komplette Anspeisung / Alimentation complète / Alimentacion completa
7	41801600400	Guarnizione gruppo caricamento / Gasket / Dichtung / Joint / Junta
8	41801702600	Guarnizione / Gasket / Dichtung / Joint / Junta

DOC COMFORT AIR 9 UP! M1

Gruppo accensione / Ignition group / Entzündung Gruppe / Groupe d'allumage / Grupo ignición

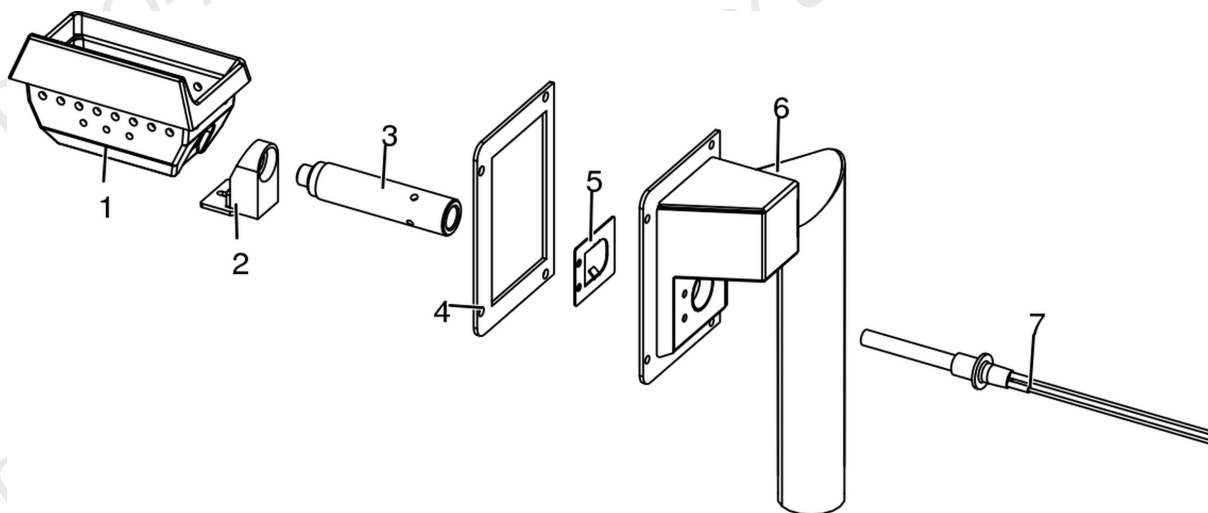

N°	Codice/Code	Descrizioni / Description / Beschreibung / Description / Descripción
1	4130170030100	Braciere ghisa / Cast iron brazier / Brennschale aus Guß / Brasero en fonte / Brasero de arrabio
2	41411741740V	Blocchetto / Little stop / Kleiner Stopper / Petit stop / Tope pequeno
3	41201705400	Condotto candelella / Sparkplug conduit / Zündkerzenkanal / Conduit bougie / Conducto bujía
4	41801702000	Guarnizione scatola / Box gasket / Gehäuse Dichtung / Joint de boite / Burlete caja
5	41401711131	Staffa a molla / Spring bracket / Federhalterung / Support à ressort / Soporte de resorte
6	41411741440V	Scatola aspirazione / Air inlet box / Lufteingangs Schachtel / Coffret entrée d'air / Caja entrada aire
7	41451308101	Candelella 315 Watt / Sparkplug 315 Watt / Zündkerze 315 Watt / Bougie 315 Watt / Bujía 315 Watt
7	41451308150	Kit 25 candelette 315 Watt / 25 Sparkplugs 315 Watt kit / Bausatz 25 Zündkerzen 315 Watt / Kit 25 Bougies 315 Watt / Kit 25 Bujías 315 Watt
7	41452009900	Candelella 300 Watt / Sparkplug 300 Watt / Zündkerze 300 Watt / Bougie 300 Watt / Bujía 300 Watt

DOC COMFORT AIR 9 UP! M1

Gruppo aria comburente / Combustion air group / Verbrennungsluft Gruppe / Groupe air comburant / Grupo aire comburente

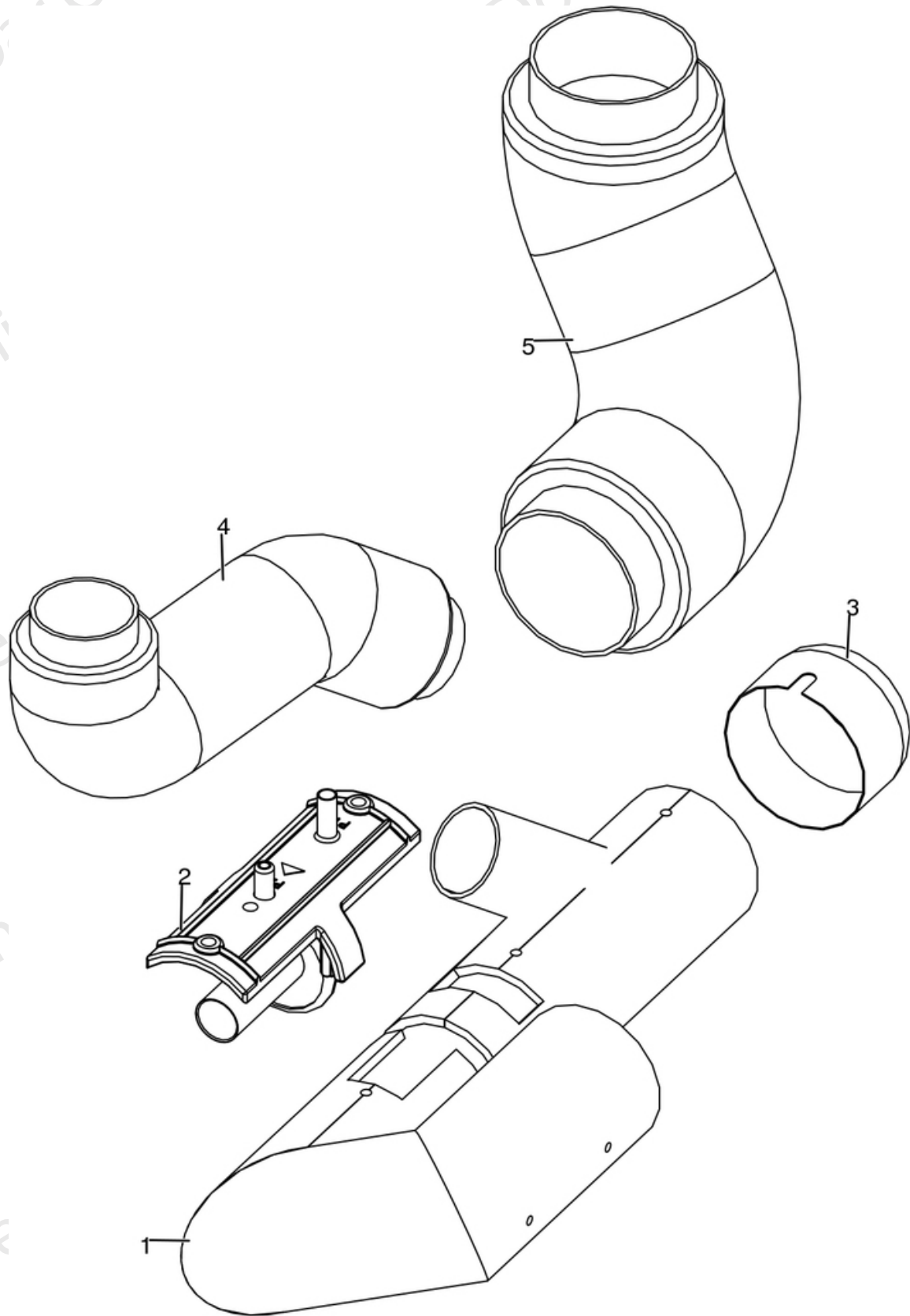

N°	Codice/Code	Descrizioni / Description / Beschreibung / Description / Descripción
1	41601703360	Tubo aspirazione zincato / Zinc-coated air inlet pipe / Verzinkt Lufteingangsrohr / Tuyau entrée d'air galvanisé / Tubo entrada aire cincado
2	41601301851	Componente rilevamento portata aria / Air flow measure component / Bauteil für Messung der Luftmenge / Composent pour la mesuration de la quantité d'air / Componente por la medida de l'aire
3	41401036100	Filtro antipolvere / Anti-dust filter / Staubschutzfilter / Filtre antipoussière / Filtro de protección polvo
4	41801601900	Tubo aspirazione pulizia vetro / Inlet pipe for cleaning glass air / Glasreinigungs Lufteingangsrohr / Tuyau entrée pour l'aire de nettoyage du vitre / Tubo entrada por l'aire de limpieza vidrio
5	41801601700	Tubo aspirazione camera combustione / Combustion chamber aspiration tube / Verbrennungskammer Förderrohr / Tuyau aspiration air chambre de combustion / Tubo aspiración aire cámara de combustión

DOC COMFORT AIR 9 UP! M1

Gruppo fumi / Smoke group / Rauchgruppe / Groupe fumées / Grupo de humos

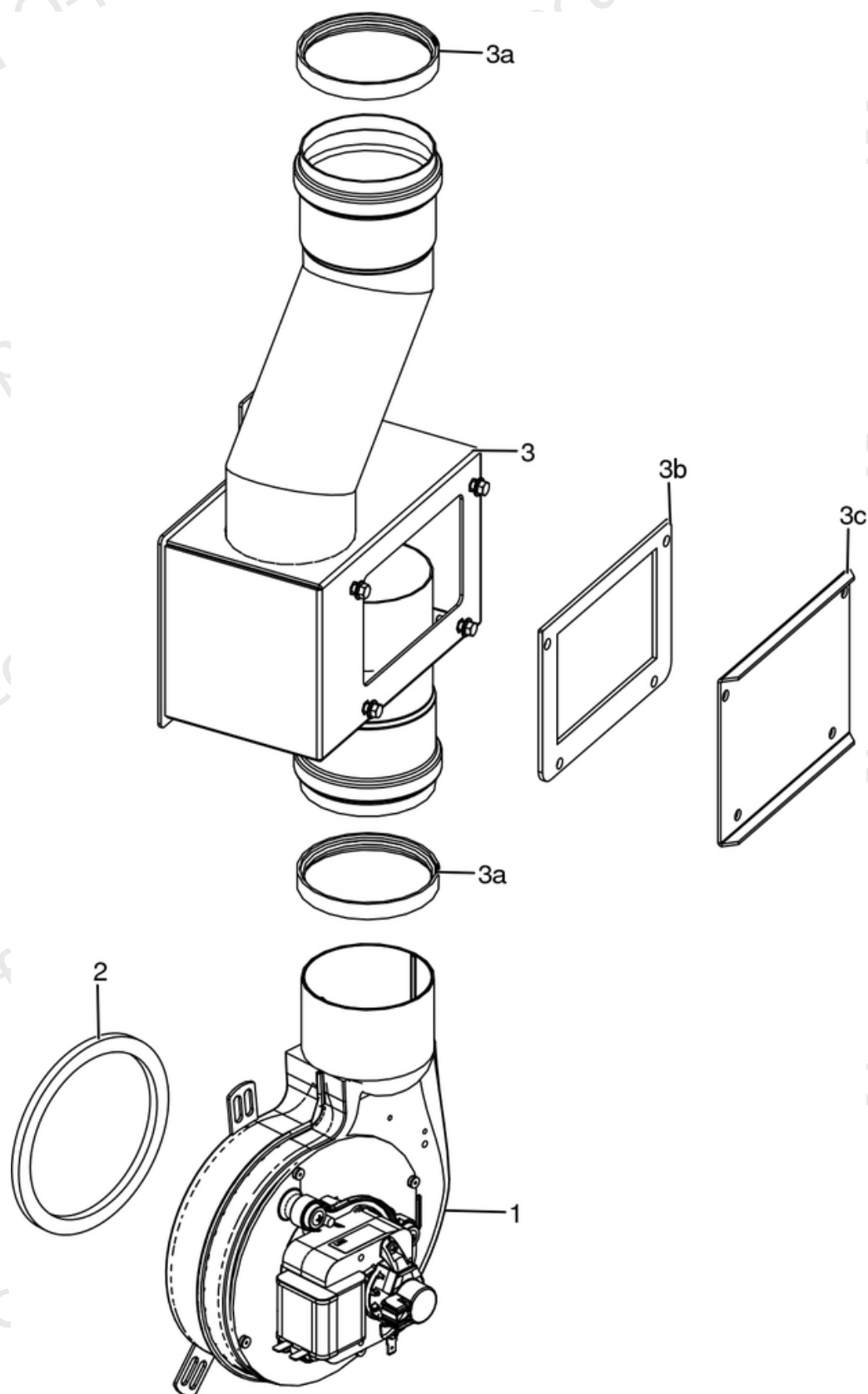

N°	Codice/Code	Descrizioni / Description / Beschreibung / Description / Descripción
1	41451406501	Ventilatore fumi / Smoke exhausted fan / Rauchgasgebläse / Ventilateur fumées / Ventilador humos
1	41801002600	Guarnizione adesiva voluta fumi / Adhesive gasket smoke volute / Haftendichtung Rauchvolute / Joint adhesive volute fumées / Junta adhesiva voluta humos
1	41451209300	Encoder per ventilatore fumi marchi LN2/SIT / Encoder for LN2/SIT smoke fan / Encoder für LN2/SIT Rauchgasgebläse / Encoder pour ventilateur des fumées marques LN2/SIT / Encoder para ventilador humos marcas LN2/SIT
1	41452009200	Encoder per ventilatore fumi marchio EMC / Encoder for EMC smoke fan / Encoder für EMC Rauchgasgebläse / Encoder pour ventilateur des fumées marque EMC / Encoder para ventilador humos marca EMC
2	41801002600	Guarnizione adesiva voluta fumi / Adhesive gasket smoke volute / Haftendichtung Rauchvolute / Joint adhesive volute fumées / Junta adhesiva voluta humos
2	41801599850	Kit 50 guarnizioni / Kit 50 gaskets / Bausatz 50 Dichtungen / Kit 50 joints / Kit 50 juntas
3	41411800251	Scatola fumi / Fumes box / Rauchabzug / boîte à fumée / Caja humos
3a	40120969	Guarnizione silicone (5pz) / Silicone Gasket (5pc.) / Silikondichtung (5 St.) / Joint en silicone / Junta en silicona
3b	41801702000	Guarnizione scatola / Box gasket / Gehäuse Dichtung / Joint de boîte / Burlete caja
3c	41401800430	Tappo scatola fumi / Plug fume box / Klappe Rauchabzug / Clapet boîte à fumée / Tapon caja de humos

DOC COMFORT AIR 9 UP! M1

Gruppo elettrico ed elettronico fino al SN 2104090060013 escluso / Electrical and electronic group up to SN 2104090060013 excluded / Elektrische und elektronische Gruppe bis zur SN 2104090060013 ausgeschlossen / Groupe électrique et électronique jusqu'au SN 2104090060013 exclue / Grupo eléctrico y electrónico hasta NS 2104090060013 excluido

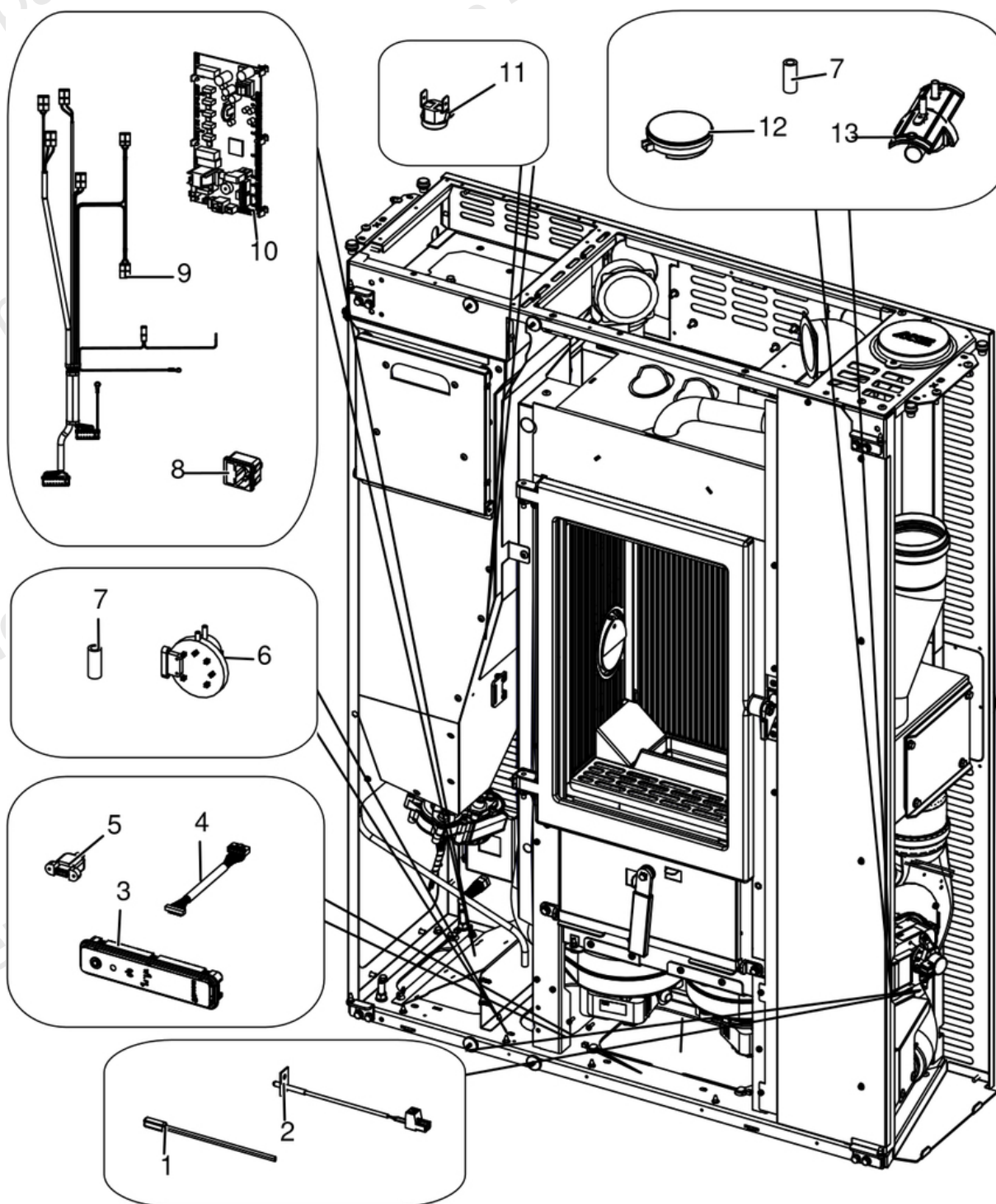

N°	Codice/Code	Descrizioni / Description / Beschreibung / Description / Description
----	-------------	--

1	4160386	Sonda temperatura ambiente/acqua / Room/Water temperature sensor / Raum- Wassertemperaturfühler / Sonde température ambiance/eau / Sonda temperatura ambiente/agua
2	41451703600	Sonda fumi con flangia con morsettiera L.980 / Smoke sensor with flange with terminal board L.980 / Rauchsonde mit Flansche mit Klemmenbrett L.980 / Sonde fumées avec bride avec serre-câble L.980 / Sonda humos con brida con borne L.980
3	41451602802	Pannello di emergenza Wireless / Wireless emergency display / Wireless Notfall-Blende / Panneau d'urgence wireless / Panel emergencia wireless
4	41451801600	Cavo flat 20 vie L.600 mm / Flat cable 20 pin L.600 mm / Flat-Kabel 20polig L.600 mm / Cable flat 20 voies L.600 mm / Flat cable 20 vias L.600 mm
5	41451403200	Cavo USB da pannello L.500 / USB Cable from display L.500 / USB Kabel von Notfalldisplay L.500 / Câble USB de panneau L.500 / Cable USB del panel L.500
6	41451003700	Pressostato / Pressure switch / Druckschalter / Pressostat / Presostato
7	4120631A	Tubicino siliconico - 5m / Silicon tube - 5m / Silikonrohr - 5m / Petit tuyau en silicone - 5m / Tubo silicónico - 5m
8	41451104100	Presa con fusibile / Socket with fuse / Steckdose mit Sicherung / Prise avec fusible / Toma con fisible
9	41451801000	Cablaggio / Wiring / Verdrahtung / Cablage / Cableado
9	41451803550	Kit cablaggi messa a terra / Grounding wiring kit / Erdungskabelbaum / Kit mise à terre / Kit cableado a tierra
10	41451802200	Scheda elettronica MAESTRO / Electronic board MAESTRO / Elektronische Platine MAESTRO / Carte electronique MAESTRO / Tarjeta electronica MAESTRO
11	412007004	Clickson 110°C / Clickson 110°C / Clickson 110°C / Clickson 110°C / Clickson 110°C
12	41451303400	Trasduttore di pressione / Pressure transducer / Active-Wandler / Transducteur de pression / Transductor de pression
13	41601301851	Componente rilevamento portata aria / Air flow measure component / Bauteil für Messung der Luftmenge / Composent pour la mesuration de la quantité d'air / Componente por la medida de l'aire

DOC COMFORT AIR 9 UP! M1

Gruppo elettrico ed elettronico dal SN 2104090060013 incluso / Electrical and electronic group from SN 2104090060013 included / Elektrische und elektronische Gruppe ab SN 2104090060013 eingeschlossen / Groupe électrique et électronique à partir du NS 2104090060013 incluse / Grupo eléctrico y electrónico a partir de NS 2104090060013 incluido

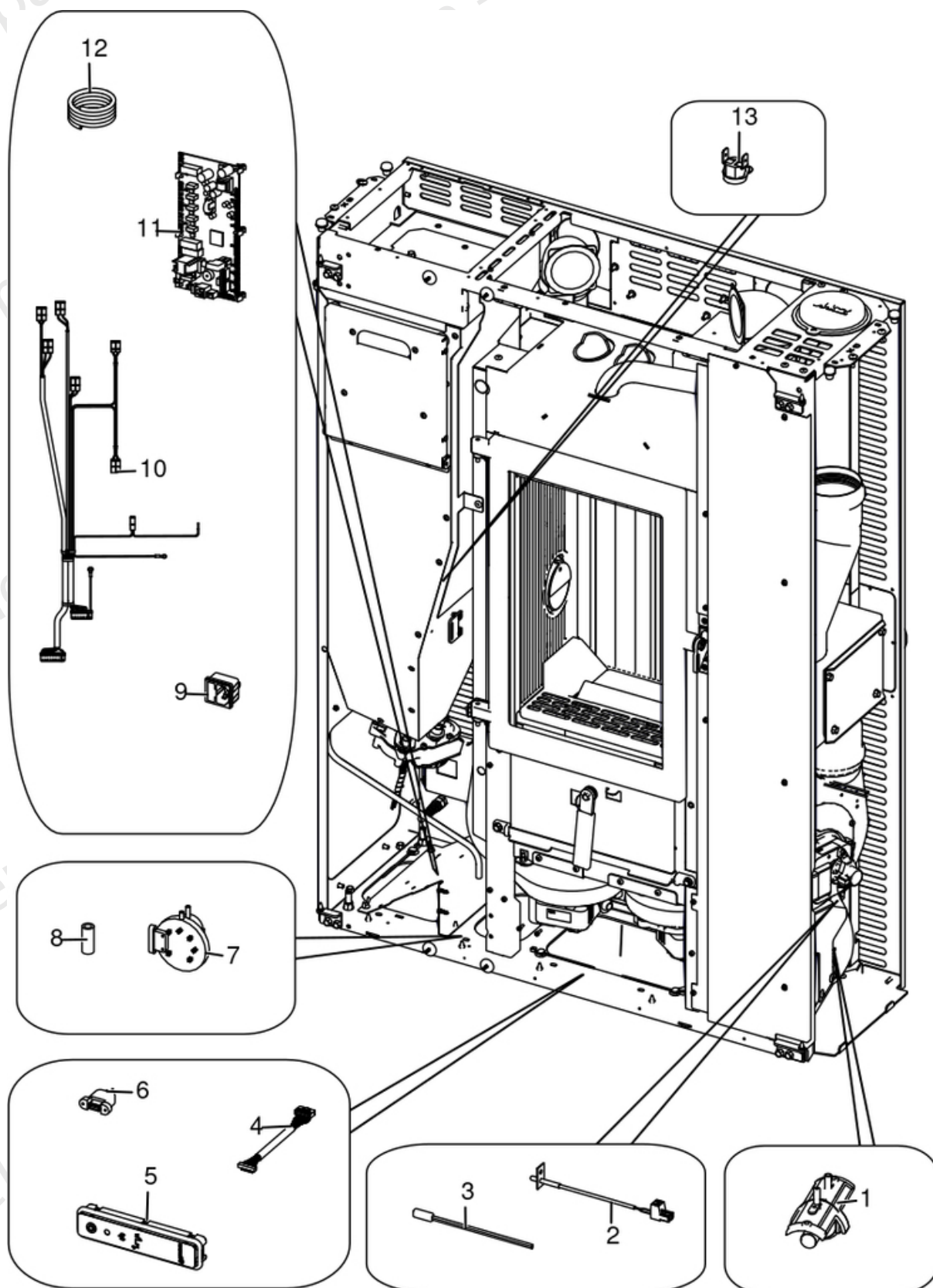

N°	Codice/Code	Descrizioni / Description / Beschreibung / Description / Descripcion
	41451803550	Kit cablaggi messa a terra / Grounding wiring kit / Erdungskabelbaum / Kit mise à terre / Kit cableado a tierra
1	41601301851	Componente rilevamento portata aria / Air flow measure component / Bauteil für Messung der Luftmenge / Composent pour la mesuration de la quantité d'air / Componente por la medida de l'aire
2	41451703600	Sonda fumi con flangia con morsettiera L.980 / Smoke sensor with flange with terminal board L.980 / Rauchsonde mit Flansche mit Klemmbrett L.980 / Sonde fumées avec bride avec serre-câble L.980 / Sonda humos con brida con borne L.980
3	4160386	Sonda temperatura ambiente/acqua / Room/Water temperature sensor / Raum- Wassertemperaturfühler / Sonde température ambiante/eau / Sonda temperatura ambiente/agua
4	41451801600	Cavo flat 20 vie L.600 mm / Flat cable 20 pin L.600 mm / Flat-Kabel 20polig L.600 mm / Cable flat 20 voies L.600 mm / Flat cable 20 vias L.600 mm
5	41451602802	Pannello di emergenza Wireless / Wireless emergency display / Wireless Notfall-Blende / Panneau d'urgence wireless / Panel emergencia wireless
6	41451403200	Cavo USB da pannello L.500 / USB Cable from display L.500 / USB Kabel von Notfalldisplay L.500 / Câble USB de panneau L.500 / Cable USB del panel L.500
7	41451003700	Pressostato / Pressure switch / Druckschalter / Pressostat / Presostato
8	4120631A	Tubicino silicónico - 5m / Silicon tube - 5m / Silikonrohr - 5m / Petit tuyau en silicone - 5m / Tubo silicónico - 5m
9	41451104100	Presa con fusibile / Socket with fuse / Steckdose mit Sicherung / Prise avec fusible / Toma con fisible
10	41451904901	Cablaggio / Wiring / Kabelbaum / Cablage / Cableado
11	41451904300	Scheda madre MAESTRO / Motherboard MAESTRO / Hauptplatine MAESTRO / Carte mère MAESTRO / Tarjeta madre MAESTRO
11	41451904300A	Sensirion / Sensirion / Sensirion / Sensirion / Sensirion
12	41801902500	Spirale Rilsan (30 m.) / Rilsan spiral (30 m.) / Spirale Rilsan (30 M.) / Spirale Rilsan (30 m.) / Espiral Rilsan (30 m.)
12	41801902500A	Spirale Rilsan (5 spire) / Rilsan spiral (5 coils) / Spirale Rilsan (5 Windungen) / Spirale Rilsan (5 spires) / Espiral Rilsan (5 espire)
13	412007004	Clickson 110°C / Clickson 110°C / Clickson 110°C / Clickson 110°C / Clickson 110°C

DOC COMFORT AIR 9 UP! M1

Gruppo ventilazione / Ventilation group / Lüftungsgruppe / Groupe de ventilation / Grupo de ventilación

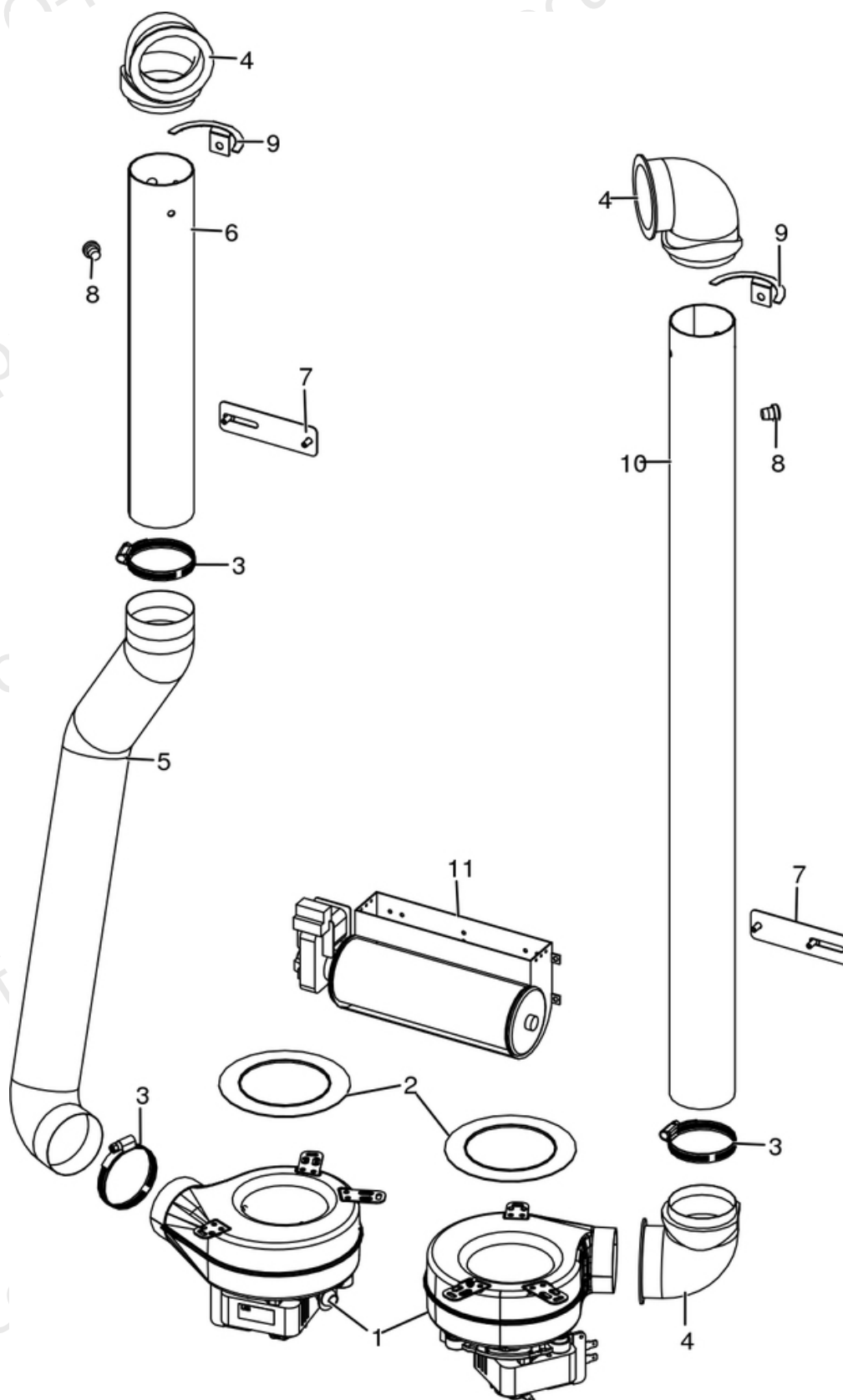

N°	Codice/Code	Descrizioni / Description / Beschreibung / Description / Descripcion
1	41451503300	Ventilatore centrifugo / Air fan / Lufgebläse / Ventilateur air / Ventilador aire
2	41801601600	Guarnizione ventilatore / Fan gasket / Dichtung des Gebläses / Joint du ventilateur / Junta ventilador
3	41200902000	Fascette Ø 64-76 mm (2 pz) / Clamps Ø 64-76 mm (2 pcs) / Rohrschellen Ø 64-76 mm (2 Stck) / Colliers Ø 64-76 mm (2 pcs) / Bandas Ø 64-76 mm (2 pzs)
4	41601003600	Tubo 90° / Pipe 90° / Rohr 90° / Tuyau 90° / Tubo 90°
5	4009003	Tubo flessibile Ø 60 mm lunghezza 1,5 m / Flex pipe Ø 60 mm lenght 1,5 m / Schlauch Ø 60 mm Länge 1,5 m / Tuyau flexible Ø 60 mm longueur 1,5 m / Tubo flexible Ø 60 mm lungueza 1,5 m
5	4009017	Tubo flessibile Ø 60 mm lunghezza 8 m / Flex pipe Ø 60 mm lenght 8 m / Schlauch Ø 60 mm Länge 8 m / Tuyau flexible Ø 60 mm longueur 8 m / Tubo flexible Ø 60 mm lungueza 8 m
6	41601703260	Tubo aria Ø 60 corto zincato / Short zinc-coated air pipe Ø 60 / Kurz verzinkter Luftrohr Ø 60 / Tuyau air galvanisé court Ø 60 / Tubo aire cincado corto Ø 60
7	41401711610	Staffa blocco tubo aria / Air pipe blocking bracket / Luftrohr Bügel / Étrier blocage du tuyau air / Abrazadera bloqueo de tubo aire
8	4120180	Gommini paracolpi (4 pz) / Rubber bumpers (4 pcs.) / Schlagschutzgummi (4 Stck) / Pièces caoutchouc antichoc (4 pcs) / Cauchitos anti-golpes (4 pz)
9	41401711730	Staffa fissaggio curve 90° / Fixing bracket for 90° bend / Haltebügel Verlauf 90° / Étrier fixation coude 90° / Abrazadera fijacion curva 90°
10	41601703160	Tubo aria Ø 60 lungo zincato / Long zinc-coated air pipe Ø 60 / Lang verzinkter Luftrohr Ø 60 / Tuyau air galvanisé long Ø 60 / Tubo aire cincado largo Ø 60
11	41451800900	Ventilatore tangenziale / Warm air fan / Luftgebläse / Ventilateur air / Ventilador aire